

INSTRUMENT CATHODE-RAY TUBE

7 cm diagonal, rectangular flat faced mono accelerator oscilloscope tube primarily for use in inexpensive oscilloscopes and monitors. This tube features a 1,5 W cathode with short warm-up time (quick-heating cathode).

QUICK REFERENCE DATA

Accelerator voltage	$V_{g2, g4, g5 (R)}$	1000 V
Display area		60 mm x 36 mm
Deflection coefficient		
horizontal	M_x	12,5 V/cm
vertical	M_y	20 V/cm

OPTICAL DATA

Screen		
phosphor type		GY, colour green
persistence		medium
Useful screen dimensions		≥ 60 mm x 36 mm
Useful scan		
horizontal	\geq	60 mm
vertical	\geq	36 mm
Spot eccentricity in horizontal and vertical directions	$<$	5 mm

HEATING

Indirect by a.c. or d.c. *

Heater voltage	V_f	6,3 V
Heater current	I_f	0,24 A

MECHANICAL DATA

Mounting position: any

The tube should not be supported by the base alone and under no circumstances should the socket be allowed to support the tube.

Net mass	approx. 350 g
Base	12-pin all glass; JEDEC B12-246

* Not to be connected in series with other tubes.

Dimensions and connections

See also outline drawing

Overall length	≤	225 mm
Faceplate dimensions	≤	72,5 x 49 mm

Accessories

Socket, supplied with tube	type 55589/55594
Mu-metal shield	type 55535

FOCUSING

electrostatic

DEFLECTION

double electrostatic

x-plates

symmetrical

y-plates

symmetrical

Angle between x and y-traces

 $90 \pm 1^\circ$

Angle between x-trace and horizontal axis of the face

 $\leq 3^\circ *$

If use is made of the full deflection capabilities of the tube the deflection plates will block part of the electron beam, hence a low impedance deflection plate drive is desirable.

CAPACITANCES

x ₁ to all other elements except x ₂	C _{x1(x2)}	3 pF
x ₂ to all other elements except x ₁	C _{x2(x1)}	3 pF
y ₁ to all other elements except y ₂	C _{y1(y2)}	4 pF
y ₂ to all other elements except y ₁	C _{y2(y1)}	4 pF
x ₁ to x ₂	C _{x1x2}	1,5 pF
y ₁ to y ₂	C _{y1y2}	1,8 pF
Control grid to all other elements	C _{g1}	5,5 pF
Cathode to all other elements	C _k	3 pF

* The tube is provided with a rotation coil, concentrically wound around the tube neck, enabling the alignment of the x-trace with the mechanical x-axis of the screen. The coil has 1000 turns and a maximum resistance of 250 Ω. Under typical operating conditions, a maximum of 10 ampere-turns are required for the maximum rotation of 3°. This means the required current is 10 mA maximum at a required voltage of 2,5 V maximum.

DIMENSIONS AND CONNECTIONS

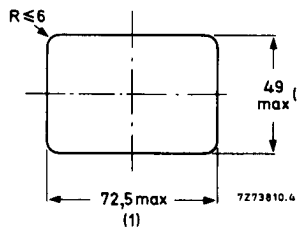
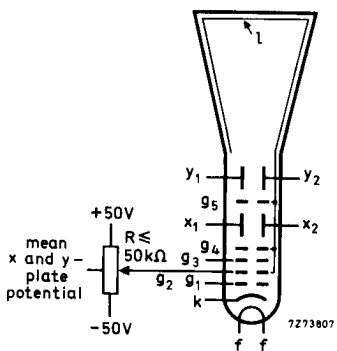
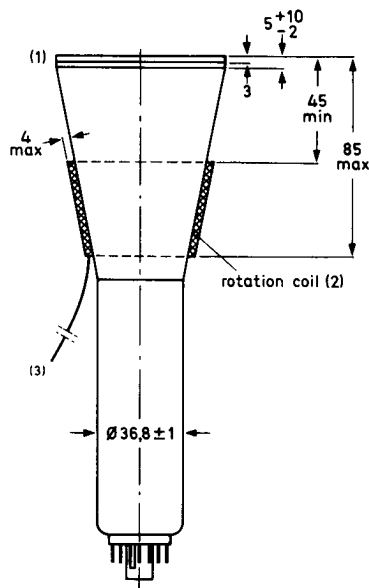
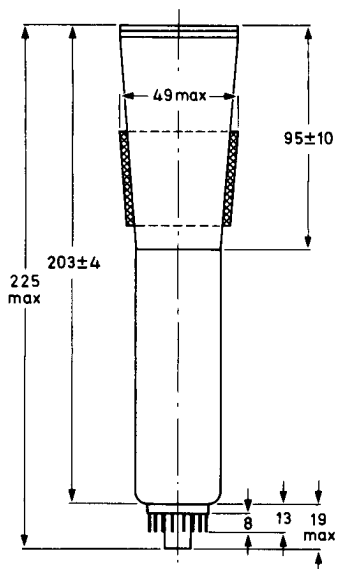

- (1) The bulge at the frit seal does not exceed the maximum dimensions.
- (2) The coil is fixed to the envelope by means of adhesive tape.
- (3) The length of the connecting leads of the rotation coil is min. 350 mm.

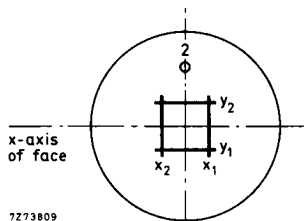

bottom view

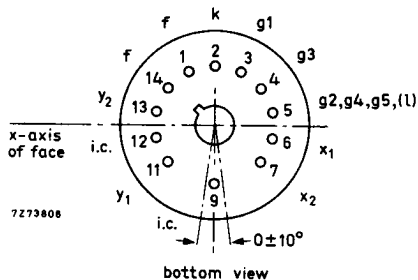

bottom view

TYPICAL OPERATION

Conditions (note 1)

Accelerator voltage	$V_{g2, g4, g5(\ell)}$	1000 V	
Astigmatism control voltage	$\Delta V_{g2, g4, g5(\ell)}$	± 50 V	(note 2)
Focusing electrode voltage	V_{g3}	100 to 180 V	
Cut-off voltage for visual extinction of focused spot	$-V_{g1}$	11 to 35 V	

Performance

Useful scan			
horizontal		>	60 mm
vertical		>	36 mm
Deflection coefficient			
horizontal	M_x	<	12,5 V/cm
		<	13,8 V/cm
vertical	M_y	<	20 V/cm
		<	22 V/cm
Line width	l.w.		0,28 mm (note 3)
Deviation of linearity of deflection		<	2 % (note 4)
Grid drive for 10 μ A screen current	V_d	\approx	10 V
Geometry distortion	see note 5		

NOTES

- The mean x-plate potential and the mean y-plate potential should be equal to $V_{g2, g4, g5(\ell)}$ (with astigmatism control voltage set to zero).
- When putting the tube into operation the astigmatism control voltage should be adjusted only once for optimum spot size in the centre of the screen. The control voltage will be within the stated range, provided the conditions of note 1 are adhered to.
- Measured with the shrinking raster method in the centre of the screen under typical operating conditions, adjusted for optimum spot size at a beam current $I_\ell = 10 \mu\text{A}$.
As the construction of the tube does not permit a direct measurement of the beam current, this current should be determined as follows.
 - Under typical operating conditions, apply a small raster display (no overscan), adjust V_{g1} for a beam current of approx. 10 μA and adjust V_{g3} and $V_{g2, g4, g5(\ell)}$ for optimum spot quality at the centre of the screen.
 - Under these conditions, but without raster, the deflection plate voltages should be changed to: $V_{x1} = V_{x2} = 1000$ V; $V_{y1} = 300$ V; $V_{y2} = 700$ V, thus directing the total beam current to y_2 . Measure the current on y_2 and adjust V_{g1} for $I_{y2} = 10 \mu\text{A}$.
 - Set again for the conditions under a), without touching the V_{g1} control. The screen current of the resulting raster display is now 10 μA .
 - Focus optimally in the centre of the screen (do not adjust the astigmatism control) and measure the line width.
- The sensitivity at a deflection of less than 75% of the useful scan will not differ from the sensitivity at a deflection of 25% of the useful scan by more than the indicated value.
- A graticule, consisting of concentric rectangles of 57,0 mm x 33,0 mm and 56 mm x 31,6 mm is aligned with the electrical x-axis of the tube. The edges of a raster will fall between these rectangles.

LIMITING VALUES (Absolute maximum rating system)

Accelerator voltage	$V_{g2, g4, g5(\ell)}$	max.	2200 V
Focusing electrode voltage	V_{g3}	max.	2200 V
Control grid voltage	$-V_{g1}$	max.	200 V
		min.	0 V
Cathode to heater voltage		max.	125 V
		max.	125 V
Grid drive, averaged over 1 ms	V_d	max.	20 V
Screen dissipation	W_{ℓ}	max.	3 mW/cm ²
Control grid circuit resistance	R_{g1}	max.	1 M Ω