

## TELEVISION PICTURE TUBE TYPE 19ACP4

114° Magnetic Deflection  
 Rectangular Glass  
 Aluminized Screen  
 Gray Filter Glass

Electrostatic Focus  
 5-1/8" Neck Length  
 Low G<sub>2</sub> Voltage (50 Volts)

External Conductive Coating  
 Spherical Faceplate  
 No Ion Trap  
 12" x 15-1/8" Screen Size

### ELECTRICAL:

Focusing Method . . . . .	Low Voltage Electrostatic
Deflection Method . . . . .	Magnetic
Deflection Angles (Approx.):	
Horizontal . . . . .	103 Degrees
Vertical . . . . .	86 Degrees
Diagonal . . . . .	114 Degrees
Direct Interelectrode Capacitances:	
Cathode to all other electrodes, (Approx.) . . . . .	5 μμf
Grid 1 to all other electrodes, (Approx.) . . . . .	6 μμf
External Conductive Coating to Anode:	
Maximum . . . . .	1500 μμf
Minimum . . . . .	1000 μμf
Heater Current at 6.3 volts . . . . .	600 ± 30 Ma.
Heater Warm-up Time <sup>⊗</sup> . . . . .	11 Seconds

### OPTICAL:

Phosphor Number . . . . .	Aluminized P4
Light Transmittance at Center, Approximate . . . . .	78 Percent

### MECHANICAL:

Overall Length . . . . .	12-3/8 ± 1/4	Inches
Greatest Dimensions of Tube:		
Diagonal . . . . .	18-5/8 ± 1/8	Inches
Width . . . . .	16-13/32 ± 1/8	Inches
Height . . . . .	13-11/32 ± 1/8	Inches
Minimum Useful Screen Dimensions (Projected):		
Diagonal . . . . .	17-9/16	Inches
Horizontal . . . . .	15-1/8	Inches
Vertical . . . . .	12	Inches
Area . . . . .	172	Sq. Inches
Neck Length . . . . .	5-1/8 ± 1/8	Inches
Bulb . . . . .	J149	
Bulb Contact . . . . .	J1-21	
Base . . . . .	B7-208	
Basing . . . . .	BHR	
Weight . . . . .	13-1/2	Lbs.

### RATINGS:

Design Maximum System		
Unless Otherwise Specified, Voltage Values are Positive with Respect to Grid 1.		
Maximum Anode Voltage . . . . .	20000	Volts
Minimum Anode Voltage <sup>▲</sup> . . . . .	12000	Volts
Maximum Grid 4 Voltage (Focusing Electrode) . . . . .	+1100, -550	Volts
Maximum Grid 2 Voltage . . . . .	70	Volts
Cathode Voltage:		
Maximum Negative Value . . . . .	0	Volts DC
Maximum Negative Peak Value . . . . .	2	Volts
Maximum Positive Value . . . . .	154	Volts DC
Maximum Positive Peak Value . . . . .	220	Volts
Maximum Heater-Cathode Voltage		
Heater negative with respect to cathode		
During warm-up period not to exceed		
15 seconds . . . . .	450	Volts
After equipment warm-up period . . . . .	200	Volts
Heater positive with respect to cathode . . . . .		
	200	Volts

### TYPICAL OPERATING CONDITIONS:

#### CATHODE DRIVE SERVICE:

Unless Otherwise Specified, All Voltage Values are Positive with Respect to Grid 1.		
Anode Voltage . . . . .	14000	Volts DC
Grid 4 Voltage (Focusing Electrode) . . . . .	0 to 400	Volts DC
Grid 2 Voltage . . . . .	50	Volts DC
Cathode Voltage for raster cutoff . . . . .	35 to 50	Volts DC

#### LIMITING CIRCUIT VALUES:

Maximum Grid 1 Circuit Resistance . . . . .	1.5	Megohms
Minimum Grids 2 & 4 Circuit Resistance <sup>†</sup> . . . . .	10000	Ohms

<sup>⊗</sup> Heater warm-up time is defined as the time required for the voltage across the heater to reach 80% of its rated value after applying 4 times rated heater voltage to a circuit consisting of the tube heater in series with a resistance equal to 3 times rated heater voltage divided by rated heater current.

<sup>▲</sup> Brilliance and definition decrease with decreasing anode voltage. Operation with anode voltage less than 12000 volts is not recommended.

<sup>†</sup> Protective resistance in the grid 2 and grid 4 (focus electrode) circuits is advisable to prevent damage to the tube.

X-RAY WARNING: Operation with voltages in excess of 16KV may require shielding to limit radiation of very soft x-rays.

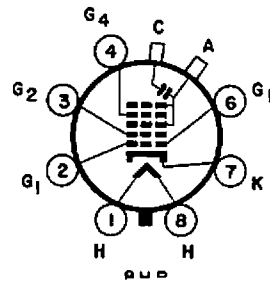
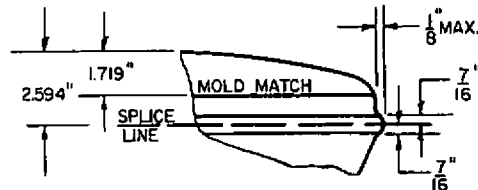
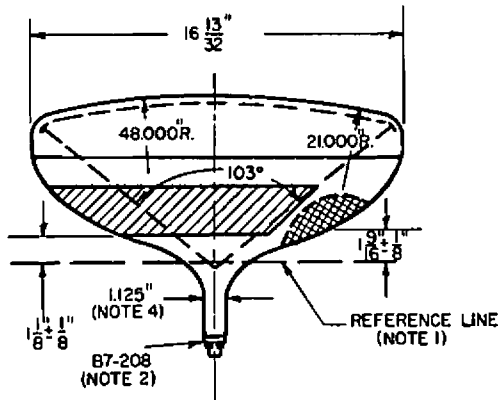
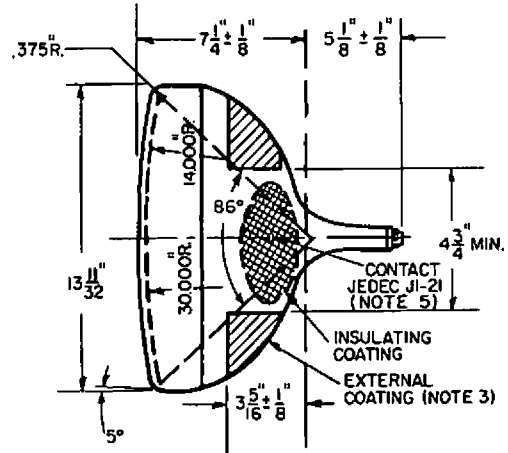
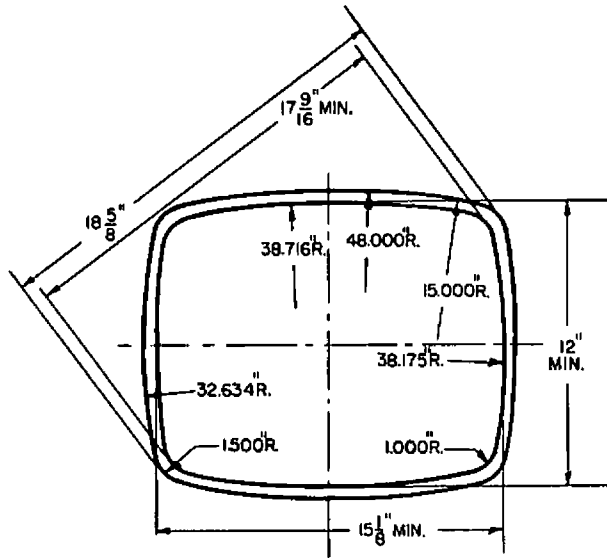

NOTE 1: Yoke Reference Line is determined by plane surface of flared end of JEDEC Reference-Line Gauge No. 126 when seated on funnel of tube. With a minimum neck length tube, the PM centering magnet (0 to 8 gauss) should extend no more than 2-1/8" from Yoke Reference Line.

NOTE 2: Lateral strains on the base pins must be avoided. The socket should have flexible leads permitting free movement. The perimeter of the base wafer will be inside a 1-3/4" diameter circle concentric with tube axis.

NOTE 3: External conductive coating forms supplementary filter capacitor and must be grounded.

NOTE 4: Neck diameter may be a maximum of 1.168" at the splice.

NOTE 5: Anode terminal alignment with pin 4 has angular tolerance about tube axis of ± 30°.