



DIRECT VIEW STORATRON TUBE

TYPE 8124

The Du Mont Type 8124 is a ten (10) inch nominal diameter Direct View Storatron Tube with a useful screen diameter of eight (8) inches. Three glass rodded electron guns are employed: two write guns and a view gun mounted on one sturdy bracket system and placed in a centrally located, three and three-quarter (3 3/4) inch diameter neck.

The write guns are identical high current, high velocity, electrostatically deflected and focused guns. Their modulated beams "write" the information into the storage target as a series of electrostatically-charged areas.

The view gun is a high current, low velocity gun which produces a "flood" of electrons which transfers the stored written information to the phosphor screen to be viewed.

The 8124 features 0 (zero) deflection plate current on both write guns and consequently a deflection linearity comparable to standard cathode-ray tubes. Other features are high light output, fast writing speed for television applications and short erase time. Although both write guns are mounted off-axis, built-in corrections maintain accurate raster orthogonality and high tracking accuracy.

The tube base is a twenty-five (25) pin phenolic base. Connections to the target assembly and screen are made through four (4) contacts in the funnel.

TYPICAL OPERATING CONDITIONS

	<u>Typical Current</u>	<u>Typical Voltage</u>	<u>Maximum Voltage</u>
<b>View Gun</b>			
Heater	600 MA	6.3 ± 5%	
Cathode	2.5 MA	0.0	0.0
Grid No. 1		0 to -100	-200
* Accelerator	250 µA (Note 1)	175	250
<b>Writing Guns A and B</b>			
Heater	600 MA	6.3 ± 5%	
Cathode		-2500	-3000
** Grid No. 1		-80 to -120	-200
* Accelerator		-105	
** Focusing Electrode		520 to 750	2500
Deflection Factors	0	28 to 40 Volts DC/ Inch/KV	
* D.P. Reference Voltage		-105	

\* With respect to view gun cathode

DE-6212 - 3

Allen B. Du Mont Laboratories

\*\* With respect to writing gun cathode

1/30/62

Divisions of Fairchild Camera and Instrument Corp.

Clifton, N. J.



DIRECT VIEW STORATRON TUBE

TYPE 8124

TYPICAL OPERATING CONDITIONS (Continued)

Phosphor P20 (can be supplied with P4 phosphor for T.V. applications)

Weight Approximately 12 Pounds

	<u>Typical Voltage</u>	<u>Typical Current (ma)</u>	<u>Maximum Volts</u>	<u>Minimum Volts</u>
Target Assembly				
Screen	10,000	.5	15,000	0
Backing Electrode	0 to 25	0	30	0
Collector Electrode	200	2.5	250	0
Collimating Electrode, E	15 to 50	5 to 50 $\mu$ A	100	0
Collimating Electrode, D	30 to 65	5 to 50 $\mu$ A	100	0

GENERAL CHARACTERISTICS

Write Guns Spot Position	Center of undeflected, focused spot of each gun will fall within a .5 inch radius at center of tube face.
Deflection Linearity (Note 2)	1%
Raster Orthogonality (Note 3)	
Cathode Heating Time	30 seconds minimum before applying other voltages
Peak Heater to Cathode Voltage	$\pm$ 200 volts
Temperature Range:	
Operating	0° C to 50° C
Non-operating	-60° C to 80° C
Humidity Range (Non-operating)	Maximum of 95% R. H.



DIRECT VIEW STORATRON TUBE

TYPE 8124

GENERAL CHARACTERISTICS (Continued)

Altitude:		
Operating		10,000 feet
Non-Operating		50,000 feet
Vibration (Non-operating)		.0150 total displacement from 10 to 50 cps.
Shock (Non-operating) (Packaged)		20 g
Display Brightness	Note 4)	600 foot lamberts at 10 KV
Erasing Uniformity	Note 5)	Maximum of .5
Storage Time	Note 6)	Minimum of 3 minutes
Erase Time	Note 7)	100 milliseconds maximum
Writing Speed	Note 8)	Minimum of 200,000 inches per second
Resolution	Note 8)	Minimum of 40 lines per inch
Brightness Levels	Note 9)	Minimum of 6 levels of display brightness

OPERATING CONSIDERATIONS

View Gun Operation

1. Apply 6.3 volts to the view gun heater and allow approximately thirty (30) seconds for warm-up.
2. Establish the following potentials:
  - Accelerator: +175 volts
  - Collector: +200 volts
  - Backing Electrode: +20 volts
  - Screen: +10,000 volts
3. Adjust the flood gun bias and collimators "E" and "D" within the range of voltages as recommended under "Typical Operating Conditions" to provide a uniform display brightness covering the useful screen area.
4. The most precise collimation adjustment can be made when the backing electrode voltage is adjusted so as to effect near visual extinction of the display brightness.



DIRECT VIEW STORATRON TUBE

TYPE 8124

OPERATING CONSIDERATIONS (View Gun Operation) (Continued)

5. To prevent possible damage to the tube, allow the viewing gun beam current to reach its normal operating value before turning on the writing gun. The viewing beam should be kept on until after the writing beam is turned off.

Initial Writing Gun Adjustment

1. Maintain sufficient negative bias to cut off the beam currents of both guns.
2. Adjust the backing electrode to plus (+) eight (8) volts.
3. Apply erasing pulses of approximately the following characteristics:
  - a) A repetition rate of 1,000 cycles per second.
  - b) A duty cycle of five percent (5%).
  - c) An amplitude of twelve (12) volts.
4. Lower the screen potential to 1.5 KV.
5. Decrease the writing gun bias on "A" gun until the write gun display is just visible. The beam current should be kept as low as possible during these adjustments to prevent damage to the tube.
6. Vary focus potential to attain optimum focus.
7. Cut off "A" gun and apply the same procedure to adjust "B" gun.
8. Centering voltages may be applied while adjusting beam "A" or "B" to position the spot or display to the desired location on the screen.
9. To obtain optimum focus over the display area of the screen, it may be necessary to apply small static astigmatism correction voltages to the deflection plates either positive or negative with respect to the accelerator to each set of deflection plates. Refocus and repeat the above procedure several times if necessary.



DIRECT VIEW STORATRON TUBE

TYPE 8124

OPERATING CONSIDERATIONS (Continued)

Writing Information Into Storage

1. Restore the screen potential to ten (10) KV.
2. Remove the erase pulses and adjust the backing electrode bias to present a display as described in Note 4-a and 4-b.
3. Decrease the writing gun bias while applying modulation voltages to either or both guns until the display appears.
4. Cut off the write gun or guns.
5. The information is now stored.

Erasure

1. Manual erasure: raise the backing electrode potential to plus twenty (+20) volts for a short period of time and restore it to the display brightness cut-off point.
2. Continuous erasure: apply erase pulses as outlined in Note 4.

NOTES

1. This current will rise by reflection from the backing electrode when it is cut off.
2. Deflection linearity (deflection factor uniformity): the deflection factor (for both D1D2 and D3D4 plate pairs, separately) for a deflection of 75% of useful scan will not differ from the deflection factor for a deflection at 25% of the useful scan by more than the indicated value.
3. Raster orthogonality: all portions of the raster pattern from either gun, adjusted so the widest points just touch the sides of a 5.550-inch square, will fall within the area bounded by the 5.550-inch square and an inscribed 5.450-inch square.



DIRECT VIEW STORATRON TUBE

TYPE 8124

NOTES  
(Continued)

4. Display brightness should be measured with the entire screen illuminated under the following conditions:
  - a) Adjust the ambient illumination so that two (2) foot lamberts plus or minus ( $\pm$ ) ten percent (10%) is reflected from the phosphor on the face of the tube.
  - b) The backing electrode should be adjusted from zero (0) to some positive voltage with respect to the flood gun cathode until any further increase would result in an increase in the measured screen brightness.
  - c) With scan adjusted to prevent screen damage, bias one writing gun grid to slightly above cut-off potential while biasing the other gun to cut-off. Overscan the entire display area with the writing gun beam while moving the raster position with the centering controls so as to completely charge the entire display area to saturation as uniformly as possible.
  - d) Cut the writing beam current off.
  - e) Measure the display brightness with a Spectro-Spot Foot Lambert Photometer (Foto Research Corp., Model U.P., or equivalent). The brightness shall be 600 foot lamberts or greater.
  
5. Set up the tube using the procedure outlined under Note 4, modifying section "b" as follows:
  - a) Set the backing electrode to plus 12 (+12) volts.
  - b) Apply positive rectangular pulses to the backing electrode having an amplitude equal to the B. E. modulation range at a repetition rate of between 100 and 1,000 cycles per second and a duty cycle of five (5) to ten (10) percent so as to obtain complete erasure in approximately ten (10) seconds.
  - c) Measure time ( $t_1$ ) from start of erasing to the instant at which any area within the minimum useful viewing diameter is reduced to ambient background-brightness level. Record time ( $t_2$ ) from start of erasing to the instant at which the entire area within the minimum useful viewing diameter area is reduced to background brightness level. The erasing-uniformity factor is defined as  $(t_2 - t_1)/t_2$ .



DIRECT VIEW STORATRON TUBE

TYPE 8124

NOTES  
(Continued)

6. Storage time is defined as the time required for background brightness to increase at the center of the display from ambient light level to thirty percent (30%) of the maximum light output as defined in Note 4.
7. Shortest erase time is defined as the time required to erase a signal of fifty (50) foot lamberts highlight brightness to one (1) foot lambert above ambient light level under the following conditions:
  - a) Set backing electrode potential as required in Note 4b.
  - b) Write into storage, a fifty (50) line raster one (1) inch high by two (2) inches wide to a brightness of fifty (50) foot lamberts.
  - c) Apply rectangular pulse or pulses with an amplitude equal to the modulation range of the backing electrode, the duration of whose sum is equal to a maximum of 100 milliseconds. The brightness at the end of this period should be not more than one (1) foot lambert above ambient light level.
8. Write a fifty (50) line raster at a writing rate of 200,000 inches per second to a display brightness of fifty (50) foot lamberts. A minimum resolution of forty (40) lines per inch by the shrinking raster method shall result. To write at a writing speed other than 200,000 inches per second, adjust beam current for maximum resolution.
9. Brightness levels may be determined visually by employing six equal steps of a staircase waveform applied to a writing gun control grid. The brightness variation of successive steps shall produce six (6) steps of display brightness.

# DUMONT

## DIRECT VIEW STORAGE TUBE TYPE 8124

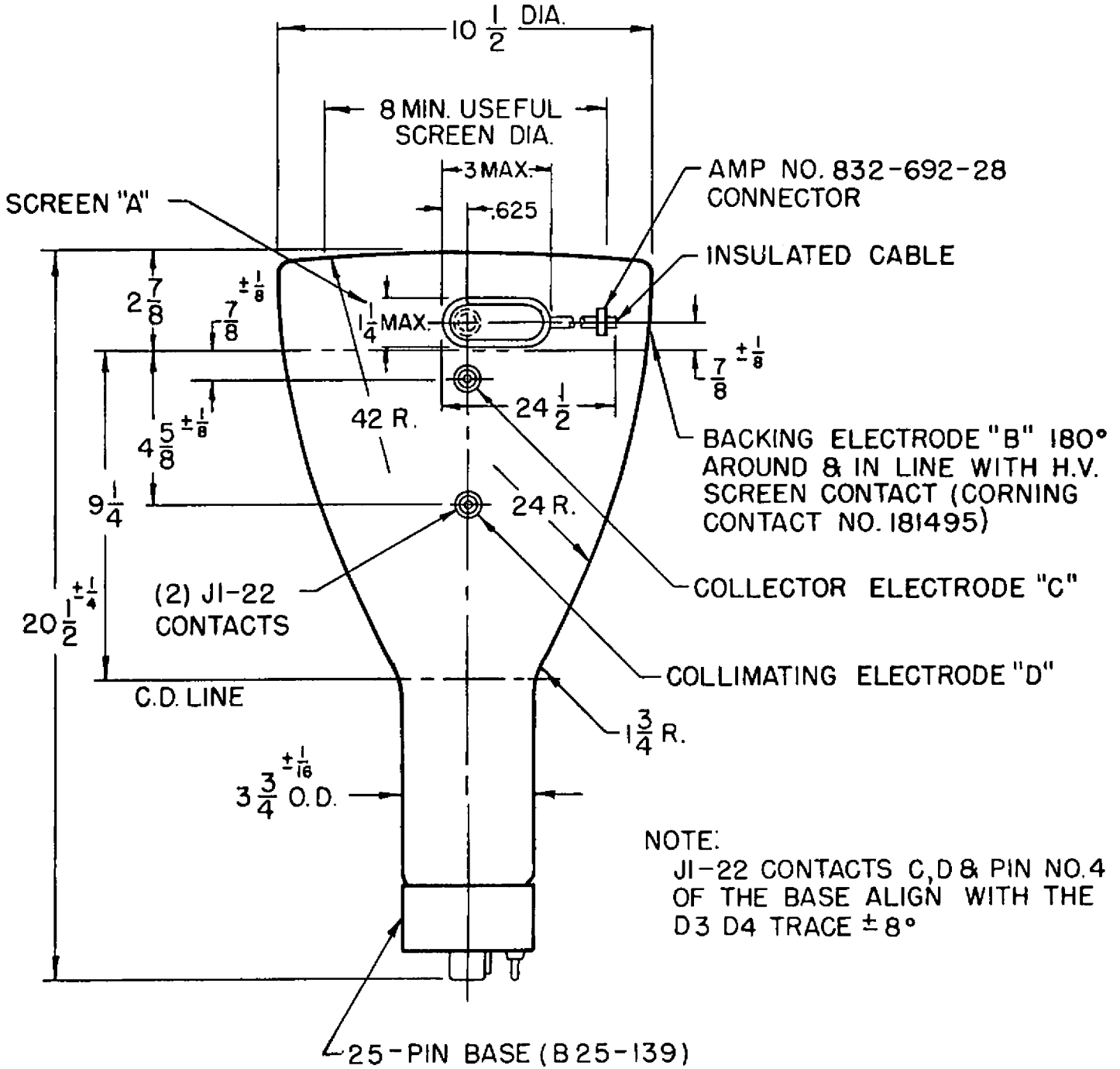



# DUMONT

## DIRECT VIEW STORAGE TUBE TYPE 8124

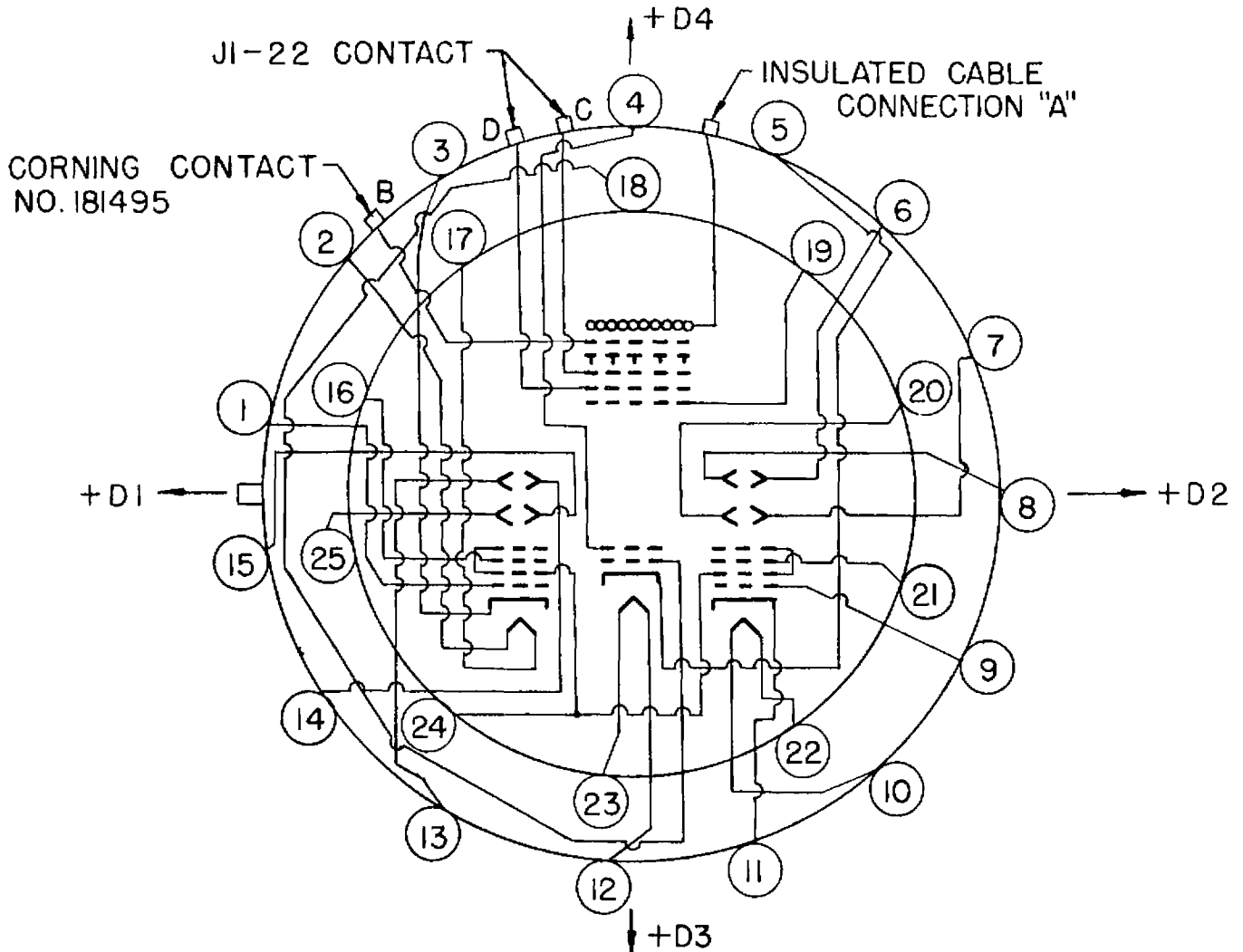

<u>WRITING GUN A</u>	
<u>PIN NO.</u>	<u>ELEMENT</u>
1	GRID NO.1
2	HEATER
3	CATHODE
13	DEFL. ELECT. D2
14	DEFL. ELECT. D1
15	DEFL. ELECT. D4
16	FOCUSING ELECT.
17	HEATER
24	ACCELERATOR
25	DEFL. ELECT. D3

<u>VIEWING GUN</u>	
<u>PIN NO.</u>	<u>ELEMENT</u>
4	ACCELERATOR
5	CATHODE
12	HEATER
18	GRID NO.1
23	HEATER

<u>WRITING GUN B</u>	
<u>PIN NO.</u>	<u>ELEMENT</u>
6	DEFL. ELECT. D1
7	DEFL. ELECT. D4
8	DEFL. ELECT. D2
9	GRID NO.1
10	HEATER
11	CATHODE
19	COLLIMATING ELECT.
20	DEFL. ELECT. D3
21	FOCUSING ELECT.
22	HEATER
24	ACCELERATOR

NOTE:  
INSULATED CABLE-SCREEN CONNECTOR.

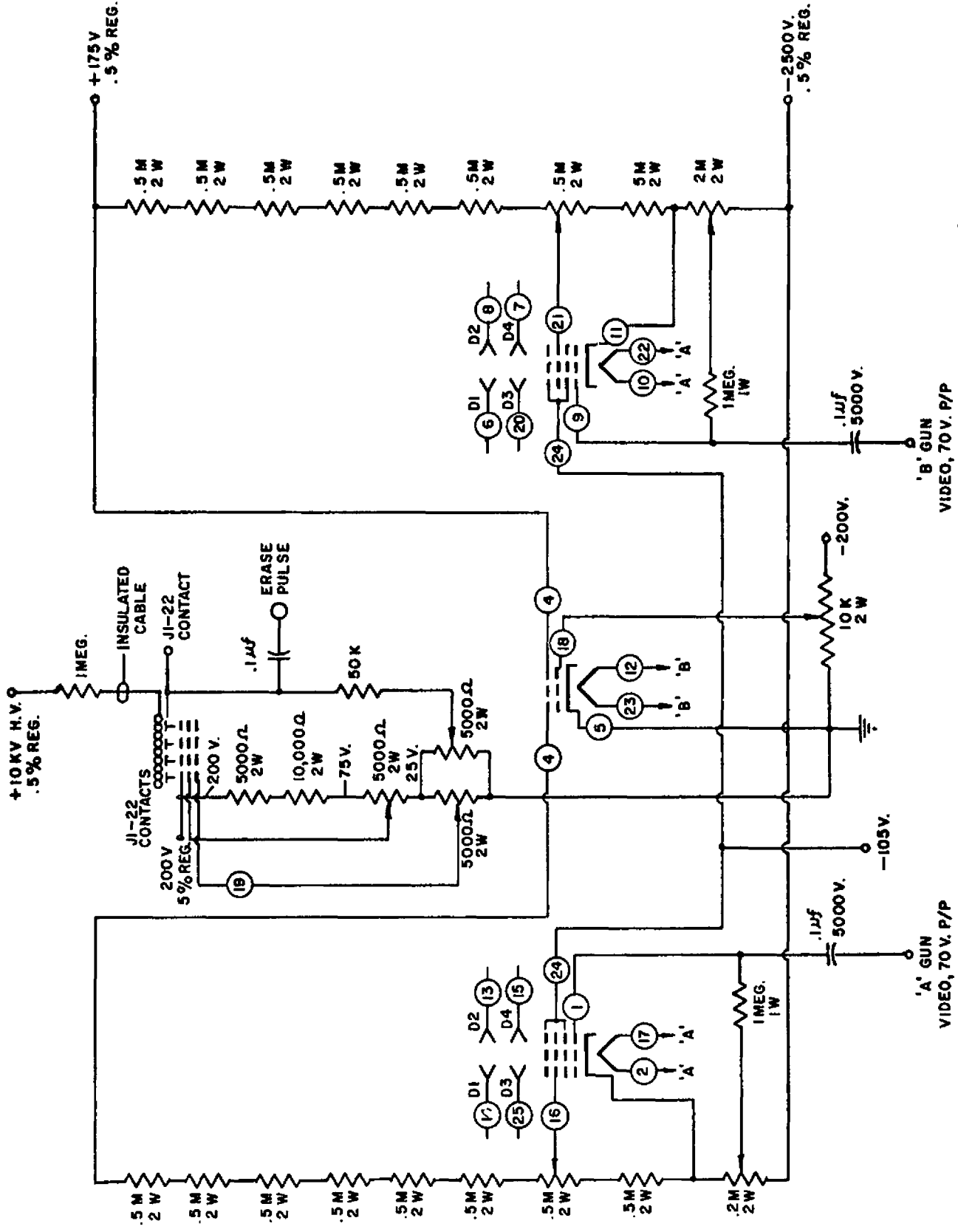

GENERAL SCHEMATIC  
 DIRECT VIEW STORASTRON  
 8124

'A' 'A' REQUIRE 5000 V. INSULATION PRI. TO SEC. OF TRANSFORMER } I TRANSFORMER  
 'B' 'B' 250V. INSULATION PRI. TO SEC. I TRANSFORMER