



ELECTRON TUBE DEPARTMENT ■ COMPONENTS DIVISION
INTERNATIONAL TELEPHONE AND TELEGRAPH CORPORATION, CLIFTON, NEW JERSEY



DOMESTIC PRICES FOR HYDROGEN THYRATRONS EFFECTIVE JANUARY 1, 1963
DOMESTIC PACK FOB NEWARK, N. J., TERMS NET 30 DAYS

<u>TUBE TYPE</u>	<u>1-5</u>	<u>6-50</u>	<u>51-250</u>	<u>251-500</u>
3C45	13.75	12.50	10.50	9.60
3C45W	30.25	27.50	21.50	19.90
4C35A	27.25	24.75	20.25	19.15
5C22	22.00	19.75	18.75	17.85
1257	*	*	*	*
5948	*	*	*	*
5948A	*	*	*	*
5949	*	*	*	*
5949A	*	*	*	*
5956	51.60	47.00	36.75	33.75
5957	51.60	47.00	36.75	33.75
5958	29.00	26.50	21.00	20.00
5959	29.00	26.50	21.00	20.00
6130	14.00	12.70	10.75	9.80
6587	51.60	47.00	36.75	33.75
6777	22.50	20.50	17.00	16.25
7178/KU-53	125.00	*	*	*
7322	*	*	*	*
7390	*	*	*	*
7583	32.00	29.00	22.75	21.50
7621/KU-70B	*	*	*	*
7665/KU-72	200.00	*	*	*
7666/KU-73	*	*	*	*
7667/KU-74	*	*	*	*
7782/KU-71	175.00	*	*	*
7866/KU-274	*	*	*	*
7890	*	*	*	*
8264/KU-52	60.00	*	*	*
8274/KU-92	300.00	*	*	*
8275/KU-93	700.00	*	*	*
8276/KU-94	1,500.00	*	*	*
E-38	64.25	58.50	47.50	45.00
KU-25	38.50	35.00	28.00	26.35
KU-27	*	*	*	*
KU-99	15.00	13.50	11.00	10.50
SGR-1	27.25	24.75	20.25	19.15

* PLEASE REQUEST QUOTATIONS ON QUANTITIES OF 501 OR MORE AND THOSE SHOWN WITH AN ASTERISK.

ITT HYDROGEN THYRATRONS

TYPE	RATINGS						HEATERS				GRID DRIVE		APPROXIMATE DIMENSIONS INCHES		WEIGHT (Pounds)	TYPE ENVELOPE
	PO M W	Pb X10 ⁹	epv KV	ib a	Ib Adc	I _p A rms	CATH. (6.3V) If Aac	RESERVOIR		MINIMUM AMPLITUDE (Volts)	MAXIMUM IMPEDANCE (Ohms)	Seated Height	Diameter			
								Eres Vac	Ires Aac							
KU-15	0.05	0.30	3.0	35	0.045	1.25	2.5	None	-	175	1500	3.6	1.1	1/16	GLASS	
KU-99	0.05	0.30	3.0	35	0.045	1.25	2.7	*	-	175	1500	4.6	1.5	3/16	GLASS	
3C45	0.05	0.30	3.0	35	0.045	1.25	2.5	None	-	175	1500	4.6	1.5	3/16	GLASS	
3C45W	0.05	0.30	3.0	35	0.045	1.25	2.7	*	-	175	1500	3.1	1.5	2/16	GLASS	
6130	0.05	0.30	3.0	35	0.045	1.25	2.5	None	-	175	1500	4.6	1.5	3/16	GLASS	
E-39	0.12	0.75	8.0	35	0.045	1.25	2.7	None	-	175	1500	3.6	1.5	3/16	GLASS	
5958	0.12	0.75	8.0	35	0.045	1.25	2.5	None	-	175	1500	3.8	1.5	4/16	GLASS	
5959	0.12	0.75	8.0	35	0.045	1.25	2.5	None	-	175	1500	3.5	1.5	4/16	GLASS	
6777	0.12	0.75	8.0	35	0.045	1.25	2.5	*	-	175	1500	4.3	1.5	4/16	GLASS	
7583	0.12	1.10	8.0	35	0.045	1.25	2.5	None	-	175	1500	3.3	1.5	3/16	GLASS	
8370/E38	0.22	1.25	5.0	90	0.100	3.0	6.7	*	-	175	1500	3.9	1.5	3/16	GLASS	
KU-81	0.33	2.0	8.0	83	0.100	2.9	6.7	*	-	175	1500	3.7	1.5	3/16	GLASS	
5956	0.33	2.0	8.0	83	0.100	2.9	6.7	*	-	175	1500	4.0	1.5	4/16	GLASS	
KU-17	0.33	2.0	8.0	83	0.100	2.9	6.7	*	-	175	1500	4.0	1.5	3/16	GLASS	
5957	0.33	2.0	8.0	83	0.100	2.9	6.7	*	-	175	1500	3.7	1.5	4/16	GLASS	
4C35A	0.35	2.0	8.0	90	0.100	3.0	6.7	*	-	175	1500	6.0	2.5	8/16	GLASS	
7621/KU-70B	0.40	2.7	8.0	100	0.100	2.0	3.0	*	-	150	1500	1.5	1.0	3/16	CERAMIC	
KU-25	1.5	3.8	12.0	300	0.200	7.8	11.6	*	-	200	500	7.8	2.5	10/16	GLASS	
KU-27	2.0	3.9	16.0	325	0.225	6.3	10.6	6.3	1.0	200	500	6.3	2.5	8/16	GLASS	
KU-28	2.0	3.9	16.0	325	0.225	6.3	10.6	6.3	1.0	200	500	5.8	2.5	8/16	GLASS	
5C22	2.0	3.2	16.0	325	0.200	6.3	11.6	*	-	200	500	7.8	2.5	10/16	GLASS	
6587	2.0	3.9	16.0	325	0.225	6.3	11.6	*	-	200	500	6.3	2.5	9/16	GLASS	
8488/KU-29	2.0	3.9	16.0	325	0.225	6.3	11.0	*	-	200	500	5.8	2.5	10/16	GLASS	
7782/KU-71	2.0	4.0	20.0	200	0.200	5.0	5.5	6.3	1.5	175	1500	1.8	1.4	5/16	CERAMIC	
KU-72Z	3.5	7.0	20.0	350	0.300	6.5	5.8	6.3	1.5	200	500	4.5	2.4	11/16	CERAMIC	
7665/KU-72	3.5	7.0	20.0	350	0.300	6.5	5.8	6.3	1.5	200	500	2.3	1.8	9/16	CERAMIC	
5949A	6.0	6.3	25.0	500	0.500	15	22.0	3.0-5.5	6.0	550	200	11.2	3.3	17/16	GLASS	
KU-54	12.0	9.0	25.0	1000	1.0	30	33.0	2.5-5.5	8.0	700	200	12.3	5.0	28/16	GLASS	
5948A	12.0	9.0	25.0	1000	1.0	30	33.0	2.5-5.5	8.0	700	200	13.5	5.0	48/16	GLASS	
7322	12.0	20.0	25.0	1000	2.0	36	22.0	6.3	6.0	500	400	5.2	3.0	3	CERAMIC	
8354	12.0	25.0	25.0	1000	2.2	40	18.0	6.3	8	500	200	4.0	3.0	27/16	CERAMIC	
7666/KU-73	18.0	20.0	25.0	1500	2.0	40	22.0	2.5-6.0	6.0	500	400	5.2	3.0	3	CERAMIC	
KU-47	33.0	20.0	33.0	2000	2.6	60	40.0	3.5-6.0	12.0	1300	70	17.8	7.0	83/16	GLASS	
1257	33.0	20.0	33.0	2000	2.6	60	40.0	3.4-6.0	12.0	1300	70	17.8	7.0	10	GLASS	
7390	33.0	30.0	33.0	2000	4.0	72	35.0	3.5-5.5	12.0	1300	70	10.0	4.5	118/16	CERAMIC	
7667/KU-74	40.0	40.0	33.0	2400	4.0	90	35.0	3.5-5.5	20.0	1300	70	10.0	4.5	118/16	CERAMIC	
KU-48	40.0	20.0	40.0	2400	2.6	60	40.0	3.5-6.0	12.0	1300	70	17.8	7.0	83/16	GLASS	
7890	48.0	55.0	40.0	2400	2.6	75	35.0	2.5-5.5	16.0	1300	70	12.0	4.5	15	CERAMIC	
7866/KU-274	60.0	55.0	50.0	2400	4.0	90	35.0	3.5-5.5	20.0	1300	70	12.0	4.5	15	CERAMIC	
KU-74B	66.0	60.0	33.0	4000	7.0	120	45.0	3.5-5.5	20.0	1300	100	9.7	6.0	1312/16	CERAMIC	
8479/KU-275A	100.0	100.0	50.0	4000	8.0	125	75.0	3.5-6.0	40.0	1500	100	15.5	9.5	45	CERAMIC	
8301/KU-275	100.0	-	50.0	4000	8.0	126	80.0	3.5-5.5	40.0	1500	100	16.0	8.5	41	CERAMIC	

* Reservoir connected internally across Cathode Heater.

ITT HYDROGEN DIODES

TYPE	PULSE DIODE			RECTIFIER			HEATERS				APPROXIMATE DIMENSIONS		WEIGHT (Pounds)	TYPE ENVELOPE
	epx KV	ib a	Ip A rms	epy KV	ib a	Ib ma	CATHODE		RESERVOIR		INCHES			
							Ef (Vac)	If (Aac)	Eres (Vac)	Ires (Aac)	Seated Height	Diameter		
KU-51	15	*	*	10	0.8	200	5.0	6.2	5.0	0.8	4.0	1.5	3/16	GLASS
8264/KU-52	18	325	6.3	15	2.0	600	5.0	11.5	5.0	4.0	6.8	2.5	9/16	GLASS
KU-91	15	150	3.5	10	1.0	300	5.0	6.5	4.0-5.0	4.0	1.8	1.4	5/16	CERAMIC
8274/KU-92	20	300	6.3	15	2.0	600	5.0	9.5	4.0-5.0	4.0	2.3	1.8	9/16	CERAMIC
8275/KU-93	30	500	15.0	20	8.0	2000	5.0	27.0	4.0-5.0	5.5	5.2	3.0	3	CERAMIC
8276/KU-94	30	2000	60.0	25	15.0	4500	5.0	28.0	4.0-5.0	20.0	8.3	4.5	11 1/16	CERAMIC
7178	16	500	15.0	*	*	*	5.0	22.0	5.0	5.0	10.2	3.3	1 1/16	GLASS

* Consult ITT Applications Engineering Department

ITT CROWBAR THYRATRONS

TYPE	RATINGS			HEATERS			APPROXIMATE DIMENSIONS		WEIGHT (Pounds)	TYPE ENVELOPE
	epy KV	1.0 ms ib a	100 ms ib a	CATHODE (6.3 Vac) If (Aac)	RESERVOIR		INCHES			
					Eres (Vac)	Ires (Aac)	Seated Height	Diameter		
KU-8329	16	500	12	12	I.C.	-	7.8	2.5	10/16	GLASS
KU-471	20	250	5	6.0	2.5-6.3	4	1.8	1.4	5/16	CERAMIC
KU-472	20	500	10	8.0	2.5-6.3	4	2.3	1.8	8/16	CERAMIC
7559	25	1500	50	30	2.5-5.5	5	13.5	5.0	4 1/16	GLASS
7590	25	1000	25	22	2.5-5.5	5	11.2	3.3	1 1/16	GLASS
7603 (KDAOI)	10	200	5	7	I.C.	-	6.0	2.5	8/16	GLASS
7605	25	3000	90	30	2.5-5.5	5	17.8	7.0	8 3/16	GLASS

ITT TRIGGERED SPARK GAPS

TYPE	STATIC BREAKDOWN VOLTAGE (KV)	RATED HOLDOFF VOLTAGE (KV)		MINIMUM TRIGGERED PULSE VOLTAGE (KV)	MAXIMUM PEAK CURRENT (AMP)	DELAY TIME AT 90% OF STATIC HOLDOFF VOLTAGE (MICROSECONDS)	APPROXIMATE DIMENSIONS		WEIGHT (Pounds)	TYPE ENVELOPE
		Minimum	Maximum				INCHES			
							Seated Height	Diameter		
KU-802	14.0	4.0	11.0	10.0	15,000	0.30	1.56	1.55	2/16	CERAMIC
KU-803A	19.0	6.0	15.0	15.0	100,000	0.50	2.25	3.50	1	CERAMIC
KU-803	30.0	8.0	25.0	20.0	100,000	0.50	2.25	3.50	1	CERAMIC
KU-803B	42.0	12.0	34.0	20.0	100,000	0.50	2.25	3.50	1	CERAMIC
KU-804	88.0	30.0	70.0	25.0	100,000	0.50	3.47	3.50	2	CERAMIC

DESIGN AND CHARACTERISTICS
OF A 100 KILOVOLT HYDROGEN THYRATRON TUBE

by

H. E. Krefft, H. Austad, and A. E. Gordon

International Telephone and Telegraph Corporation
Electron Tube Division, Easton, Pennsylvania

The peak forward voltage capability and other characteristics of hydrogen thyatron tubes made with a plurality of grids were investigated under operating conditions prescribed by Specification No. SCL-7001/80. The tubes which were of ceramic-metal design had to meet the following test requirements:

Peak forward anode voltage:	100 kilovolts
Peak anode current:	200 amperes
Test repetition rate:	1000 cps
Pulse width (70 percent):	1 microsecond
Average anode current:	0.2 ampere
P_b -Factor ($e_{py} \times i_b \times p_{rr}$):	20×10^9

Principal objectives of this development were the practical feasibility of multi-grid tubes with adequate characteristics, and an understanding of the factors which basically determine their performance and possible limitations.

The requirement of a very high voltage capability made it mandatory to think of a periodic or "iterative" design which would permit in a strictly additive manner the use of as many gradient grids as needed for reliable operation. A grid structure following this principle was designed for this investigation. It was made with "short" gradient grids; that is, grids whose axial dimensions are small as compared to their diameter. With a sufficiently flat, or "planar" type grid, favorable anode take-over characteristics could be obtained which, in the first place, would depend on baffling and aperture geometry. Furthermore, good deionization and sparking voltage characteristics were expected as a consequence of small gap volume.

In a short grid structure of this kind, the seals with the ceramic envelope of the closely spaced grids are at a small distance from each other which is determined by the length of the grid and the size of the gap. Voltage breakdown between adjacent seals, both inside and outside the tube, through which high voltage operation would be greatly limited, was overcome with the design illustrated by Figure 1. As it provided an effective protection of gaps and seals, it was used without change on 30 tubes of this type which were made with three, four and six gaps and served as experimental vehicle for this investigation.

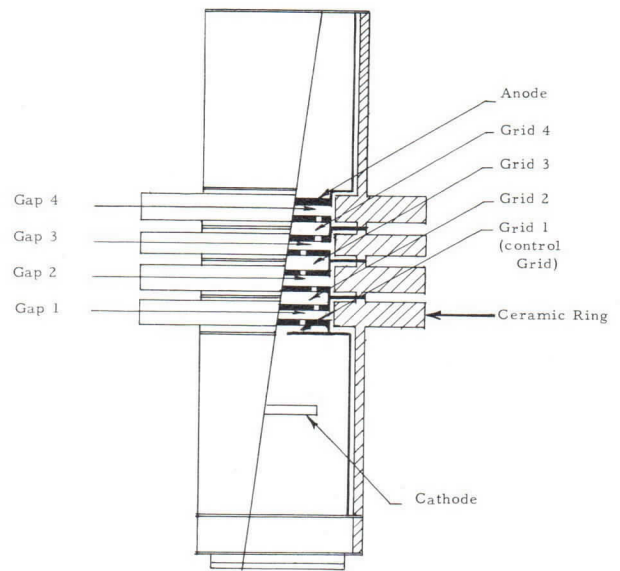

Figure 1: 100 KV - 10 KW Hydrogen Thyatron Tube. Basic design of a four-gap Tube.

The grid-envelope structure of a four-grid* tube with four gaps consists of three planar gradient grids and four ceramic envelope rings which are brazed to the grid flanges. Voltage breakdown between seals is inhibited by internal and external extensions of the rings which internally follow the grid outlines with a small clearance. Metallic deposits originating in the gaps are formed on the cylindrical surface of the extension and are prevented from forming a continuous conducting layer between seals.

For testing and evaluation of the tubes, a line-type modulator was constructed which produced the specified operating condition and had the following characteristics:

$$L_N = 138 \text{ microhenry}$$

$$L_C = 56 \text{ henry}$$

$$C_N = .001816 \text{ microfarad}$$

$$R_L = 220 \text{ ohm}$$

$$R_N = 250 \text{ ohm}$$

*The control grid is included in this number which is equal to the number of gaps.

The instrumentation included a pulse transformer for viewing the current pulse, and two capacitance dividers of 1.9 uuF for the measurement of grid voltages. All components of the test set were contained in one large oil filled steel tank. A circuit diagram is shown in Figure 2. A resistance divider of 10 megohms per gap was used for stabilizing grid potentials.

The high voltage capability of this multi-grid design became immediately evident when the first three-gap tubes were tested. They aged and operated with great facility, and anode take-over characteristics were satisfactory. One of these tubes (No. 4) was life tested for 348 hours and had an uninterrupted run of 123 hours at 90 KV. However, these tests were made with a pulse repetition rate of 320 pps, and the P_b -Factor of 7.2×10^9 was rather low.

Unexpectedly short lives were experienced in the beginning when operation at the specified ratings of 100 KV, 10 KW, 1000 pps and a P_b -Factor of 20×10^9 was attempted. The anode plate was found to be strongly eroded at the impact areas of the discharge, and high voltage breakdown through the ceramic envelope extension at the anode gap became a typical cause of failure. These defects are illustrated by the photographs in Figures 3 and 4.

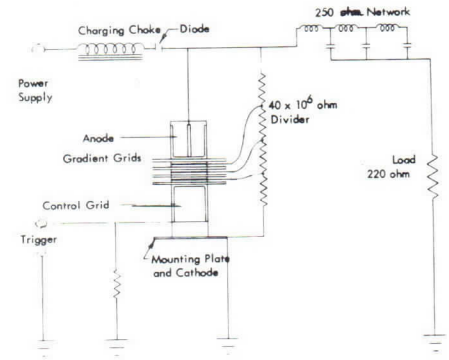

Figure 2: Circuit Diagram of the Test Modulator.

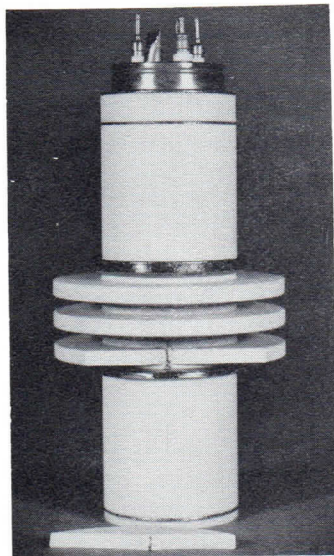

Figure 3: Three-Gap Tube damaged by voltage breakdown through the envelope ring.



Figure 4: Anode of the same tube showing deep holes at the impact areas of the discharge. Gradient grids have eight .104" dia. holes.

Anode erosion was reduced by operating the tubes under a sufficiently high gas pressure. This was not a problem as reservoir ranges were always wide and had fairly high upper limits. Range stability during life was provided by a titanium hydride reservoir containing 2.5 grams of hydride and approximately 30 liter x millimeter of hydrogen. Tube life was greatly improved in this way since the danger of voltage breakdown across the anode gap insulation was reduced at the same time. Tube lives of several hundred hours were attained.

Defocusing of the discharge at the anode plate; that is, a reduction of current density in the impact areas, was effected by substituting two slots for the eight holes normally used in the gradient grids. Erosion in the linear marks produced with this type of grid aperture was less, and a similar result was obtained by substituting tungsten for molybdenum which was commonly used.

In spite of these measures, tube life still was terminated by voltage breakdown through the ceramic envelope ring, which resulted in a leak. In most tubes this defect was caused at the external ceramic extension of the anode gap, in one tube internally, and in two other cases the gap next to the anode gap was involved or the only one affected. Improvement of this condition was attempted by avoiding high electrical field strength at the seals, and by increasing the thickness of the external extension of the envelope ring.

The voltage breakdown at the anode gap, the erosion of the anode plate, and the apparent applicability of the epy-parameter in the P_b -Factor defining dissipation at the anode, suggest that high voltage drops are formed in the anode gap during commutation. A condition of this kind is possibly indicated by the potential level of the gradient grid which is next to the anode.

Gradient grid potentials in a four gap tube made with slot type grids are shown in Figure 5. As a general rule, all grid potentials were found to be below the voltage levels established by the resistance divider. At $e_{py} = 100$ KV, the voltage drop across the anode gap thus amounted to some 30 KV for slot type grids, and was still larger for the other grid type. The potentials which are determined from the scope traces are attained by the grids between pulses as the network charges up. When they break down during anode take-over, commutation voltage drops of short duration must appear in the gaps which depend on the nature and timing of the anode take-over process.

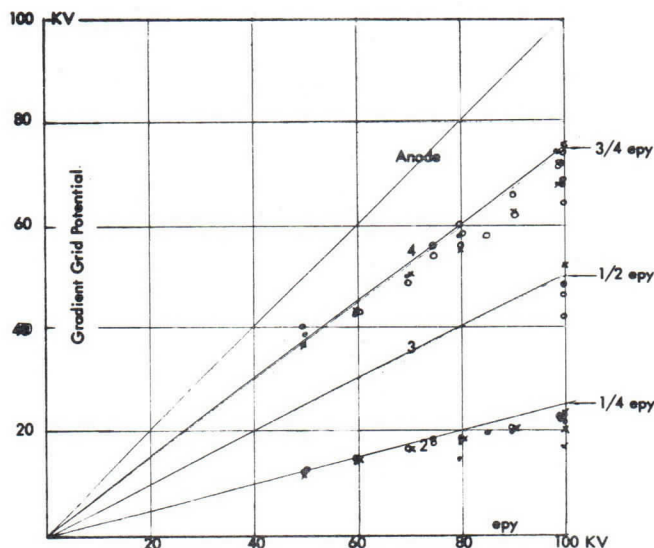

Figure 5: Gradient Grid Potentials in a Four-Gap Tube.

Anode take-over characteristics were satisfactory as take-over time was in the range of 0.2 to 0.5 microseconds and depended on e_{py} , repetition rate, and gas pressure in the same way as in one gap tubes. Take-over change was .020 to .050 microseconds. Minimum anode take-over voltage was very low for hole type grids, and between 5 and 15 KVdc for the other type. Time jitter was somewhat above the specified maximum value, and erratic. The anode to cathode voltage drop during conduction was 150 to 175 volts in four gap tubes, and the voltage drop per gap from 20 to 25 volts.

The outstanding voltage capability demonstrated by all tubes points to good sparking voltage characteristics of the gaps which were extensively investigated. Characteristics for a three and a four gap tube are shown in Figures 6 and 7. Both tubes had identical hole type grids and had been exposed to a peak forward voltage of 100 KV for about the same length of time. Sparking potentials in three gap tubes were found to be typically higher than in four gap tubes. Since comparable gaps are identical by design, and the gaps in the three gap type are exposed to higher voltage during operation, a causative relation between sparking potential levels and gap voltage drops produced by operating the tubes seems to exist.

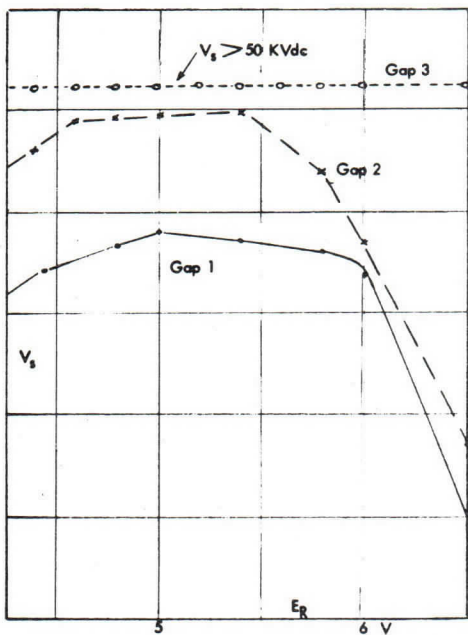

Figure 6: 3-Gap Tube.

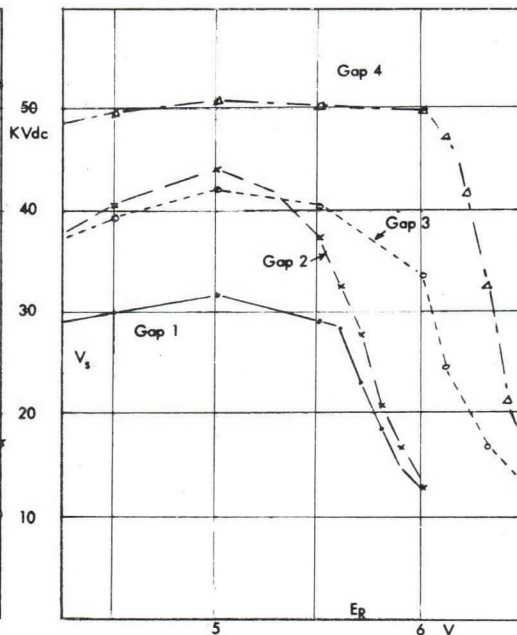

Figure 7: 4-Gap Tube.

Sparking Voltages V_s in Three and Four Gap Tubes.

The data obtained through this investigation, incomplete as they are, lead to some conclusions regarding the factors which determine the characteristics of multi-gap tubes made with short baffled grids. The ability to operate at high voltages may be explained by the fact that the grids are connected to the voltage source through the high resistance elements of the divider, so that sparking currents in the gaps are mostly too small to affect the entire tube. Depressed gradient grid potentials are due to some conductivity existing in the gaps between pulses which can be caused by conducting deposits between seals, grid emission, or a high impedance discharge condition stemming from incomplete deionization or insufficient baffling of the grids. This condition seems to be the most likely cause since deposits and grid emission can be ruled out. Breakdown of the ceramic ring at the

anode gap points to voltage drops which are higher than those existing between pulses. They are associated with the commutation process and a consequence of a successive breakdown of the gaps. Such voltage drops of short duration may also offer an explanation for the erosion of the anode plate which is at least partly due to high velocity electrons.

A peak forward voltage capability above 100 KV is indicated by this investigation. It is expected that a development beyond this voltage level will have to deal with the problems of the anode gap in the first place. Requirements on the dielectric strength of ceramic materials and on anode plate materials and design will be very high.

This investigation was carried out under Contract No. DA36-039 AMC-03272(E), Specification SCL-7001/80, placed by the U.S. Army Electronics Command, Fort Monmouth, N. J. The substantial help and advice provided by Messrs. S. Schneider, J. Creedon, and A. Buffa is gratefully acknowledged.

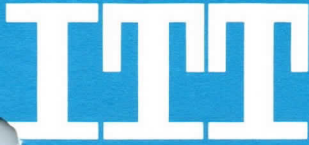

DESCRIPTION:

THE 3C45 IS A UNIPOTENTIAL CATHODE, THREE ELEMENT HYDROGEN FILLED THYRATRON DESIGNED FOR NETWORK DISCHARGE SERVICE. IN SUCH SERVICE IT IS SUITABLE FOR PRODUCING PULSE OUTPUTS OF 55 KW AT AN AVERAGE POWER LEVEL OF MORE THAN 65 WATTS. THE SPECIAL FEATURES OF THE 3C45 INCLUDE THE HIGH PEAK VOLTAGE AND CURRENT RATINGS.

ELECTRICAL DATA, GENERAL:

	<u>NOM.</u>	<u>MIN.</u>	<u>MAX.</u>	
HEATER VOLTAGE	6.3	5.7	6.6	VOLTS A.C.
HEATER CURRENT (AT 6.3 VOLTS)		2.0	2.5	AMPERES
MINIMUM HEATING TIME				2 MINUTES

MECHANICAL DATA, GENERAL:

MOUNTING POSITION			ANY
BASE	MEDIUM 4 PIN		LOW-LOSS
	PHENOLIC		A4-9
	SMALL METAL		C1-1
ANODE CAP			
COOLING (NOTE 1)			
NET WEIGHT		2.5	OUNCES
DIMENSIONS			SEE OUTLINE

RATINGS:

MAX. PEAK ANODE VOLTAGE, FORWARD		3.0	KILOVOLTS
MAX. PEAK ANODE VOLTAGE, INVERSE (NOTE 2)		3.0	KILOVOLTS
MIN. ANODE SUPPLY VOLTAGE		800	VOLTS D.C.
MAX. PEAK ANODE CURRENT		35	AMPERES
MAX. AVERAGE ANODE CURRENT		45	MILLIAMPERES
MAX. RMS ANODE CURRENT (NOTE 3)		1.25	AMPERES A.C.
MAX. EPY X 1B X PRR	0.3 X 10 ⁹		
MAX. ANODE CURRENT RATE OF RISE		750	AMPERES/USECOND
PEAK TRIGGER VOLTAGE (NOTE 4)			
MAX. PEAK INVERSE TRIGGER VOLTAGE		200	VOLTS
MAX. ANODE DELAY TIME (NOTE 5)		0.6	MICROSECOND
MAX. ANODE DELAY TIME DRIFT		0.15	MICROSECOND
MAX. TIME JITTER (NOTE 6)		0.02	MICROSECOND (INITIAL)
		0.04	USECOND (END OF LIFE)
AMBIENT TEMPERATURE	-50° TO	+90°	CENT.

TYPICAL OPERATION AS PULSE MODULATOR, DC RESONANT CHARGING:

PEAK NETWORK VOLTAGE	3.0	KILOVOLTS
PULSE REPETITION RATE	2500	PULSES/SECOND
PULSE LENGTH	0.5	MICROSECOND
PULSE FORMING NETWORK IMPEDANCE	45.2	OHMS
TRIGGER VOLTAGE	200	VOLTS
PEAK POWER OUTPUT (RESISTIVE LOAD 92% ZN)	47.2	KILOWATTS
PEAK ANODE CURRENT	35	AMPERES
AVERAGE ANODE CURRENT	.044	AMPERES D.C.

NOTE 1:

COOLING OF THE ANODE LEAD IS PERMISSIBLE, BUT THERE SHALL BE NO AIR BLAST DIRECTLY ON THE BULB.

NOTE 2:

THE PEAK INVERSE VOLTAGE SHOULD NOT EXCEED 1.5 KV DURING THE FIRST 25 MICROSECONDS AFTER CONDUCTION.

NOTE 3:

THE ROOT MEAN SQUARE ANODE CURRENT SHALL BE COMPUTED AS THE SQUARE ROOT OF THE PRODUCT OF THE PEAK CURRENT AND THE AVERAGE CURRENT.

NOTE 4:

THE VOLTAGE BETWEEN GRID AND CATHODE TERMINALS OF THE SOCKET WITH THE TUBE REMOVED SHOULD HAVE THE FOLLOWING CHARACTERISTICS:

A. VOLTAGE	175-250 VOLTS
B. DURATION	2 MICROSECONDS (AT 70% POINTS)
C. SOURCE IMPEDANCE	1500 OHMS (MAX.)
D. RATE OF RISE	200 VOLTS/MICROSECOND (MIN.)

THE LIMITS OF ANODE TIME DELAY AND ANODE TIME JITTER ARE BASED ON THE MINIMUM TRIGGER. USING THE HIGHEST PERMISSIBLE TRIGGER VOLTAGE AND LOWEST TRIGGER SOURCE IMPEDANCE MATERIALLY REDUCES THESE VALUES BELOW THE LIMITS SPECIFIED.

NOTE 5:

THE TIME OF ANODE DELAY IS MEASURED BETWEEN THE 26 PERCENT POINT ON THE RISING PORTION OF THE UNLOADED GRID VOLTAGE PULSE AND THE POINT AT WHICH EVIDENCE OF ANODE CONDUCTION FIRST APPEARS ON THE LOADED GRID PULSE.

KUTHE
3C45
HYDROGEN
THYRATRON

- 3 -

NOTE 6:

TIME JITTER IS MEASURED AT THE 50 PERCENT POINT ON THE ANODE CURRENT PULSE.

ADDITIONAL INFORMATION FOR SPECIFIC APPLICATIONS CAN BE OBTAINED FROM THE

ELECTRON TUBE APPLICATIONS SECTION
ITT COMPONENTS DIVISION
POST OFFICE BOX 412
CLIFTON, NEW JERSEY



ELECTRON TUBE DEPARTMENT ■ **COMPONENTS DIVISION**
INTERNATIONAL TELEPHONE AND TELEGRAPH CORPORATION, CLIFTON, NEW JERSEY

5-62

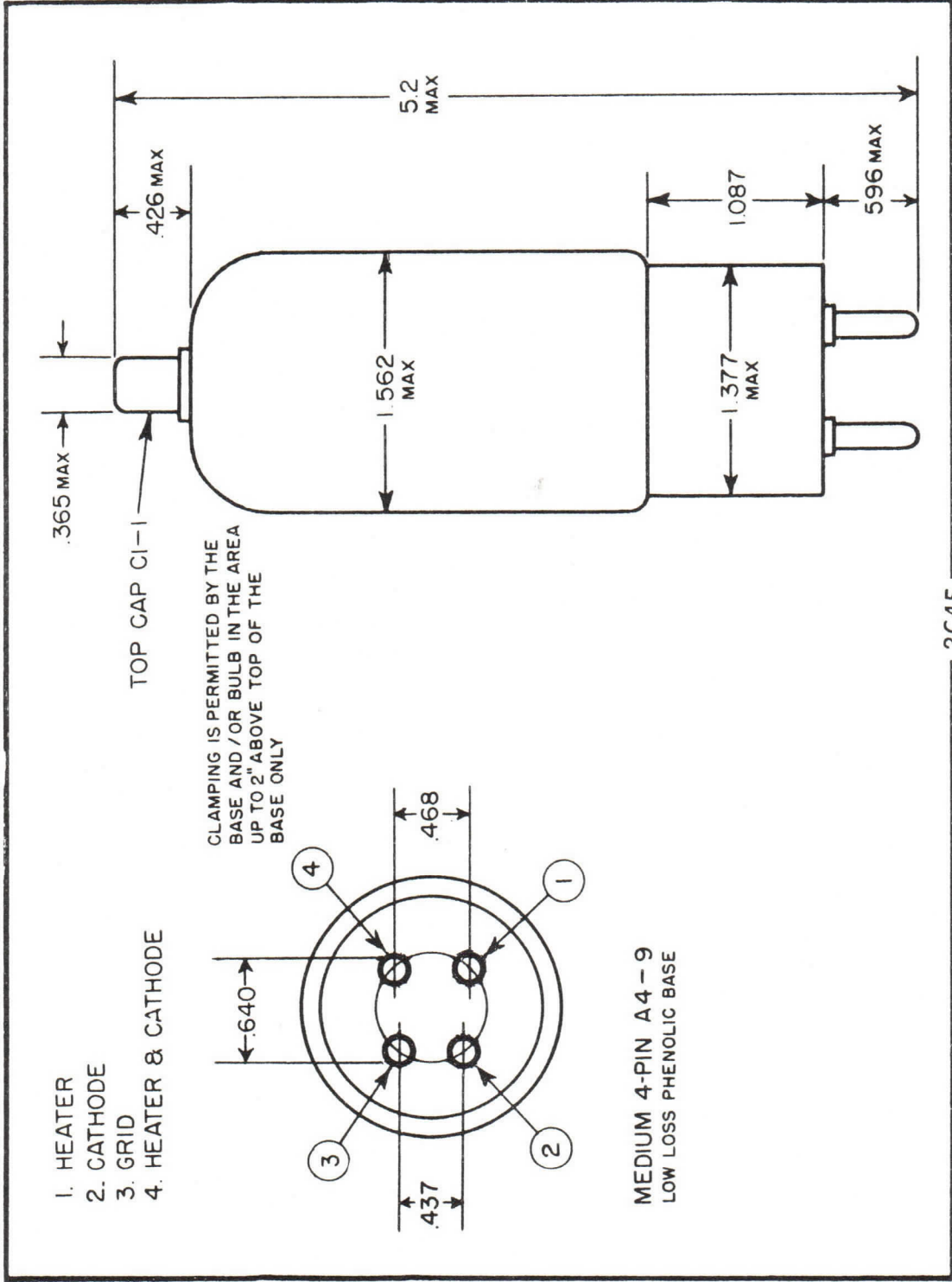

- 1. HEATER
- 2. CATHODE
- 3. GRID
- 4. HEATER & CATHODE

CLAMPING IS PERMITTED BY THE
 BASE AND/OR BULB IN THE AREA
 UP TO 2" ABOVE TOP OF THE
 BASE ONLY

MEDIUM 4-PIN A4-9
 LOW LOSS PHENOLIC BASE

engineering TUBE DATA

Kuthe



Components Division

TYPE 3C45W HYDROGEN THYRATRON

GENERAL DATA

DESCRIPTION:

The 3C45W is a unipotential cathode, three element hydrogen filled thyatron designed for network discharge service. In such service, it is suitable for producing pulse outputs of 55 KW at an average power level of more than 65 watts.

The reduced size and ruggedized construction of the 3C45W make it ideal for applications requiring a high resistance to shock and vibration. This tube type equipped with a reservoir for long stable life has the electrical ratings of the type 3C45.

Electrical Data, General	Nom.	Min.	Max.
Heater voltage.....	6.3	5.9	6.7 Volts a.c.
Heater current. $E_h=6.3$ volts.....		2.2	2.7 Amperes
Minimum heating time.....	3 Minutes		

Mechanical Data, General

Mounting position.....	Any
Base.....	Per outline
Anode Cap.....	Small metal, C1-1
Cooling.....	Note 1
Net Weight.....	2.5 Ounces

Dimensions

See outline drawing

Ratings

Max. peak anode voltage, forward....	3.0 Kilovolts
Max. peak anode voltage, inverse (Note 2).....	3.0 Kilovolts
Min. anode supply voltage.....	300 Volts d.c.
Max. peak anode current.....	35 Amperes
Max. average anode current.....	45 Milliampères
Max. RMS anode current (Note 3)....	1.25 Amperes a.c.
Max. $e_{py} \times i_b \times p_{rr}$	0.3×10^{11}
Max. anode current rate of rise.....	750 Amperes/ μ second
Peak trigger voltage.....	Note 4
Max. peak inverse trigger voltage....	200 Volts
Max. anode delay time (Note 5).....	0.6 Microsecond
Max. anode delay time drift.....	0.15 Microsecond
Max. time jitter (Note 6).....	0.02 Microsecond (initial) 0.04 μ second (end of life)
Ambient temperature.....	-50° to + 90° Cent.



COMPONENTS DIVISION

INTERNATIONAL TELEPHONE AND TELEGRAPH CORPORATION

P. O. BOX 412, CLIFTON, NEW JERSEY

**Typical Operation as Pulse Modulator,
DC Resonant Charging**

Peak network voltage.....	3.0 Kilovolts
Pulse repetition rate.....	2500 Pulses/second
Pulse length.....	0.5 Microsecond
Pulse forming network impedance....	45.2 Ohms
Trigger voltage.....	200 Volts
Peak power output (Resistive load 92% Zn).....	47.2 Kilowatts
Peak anode current.....	35 Amperes
Average anode current.....	.044 Amperes d.c.

Note 1

Cooling permitted. However, there shall be no air blast directly on the bulb.

Note 2

The peak inverse voltage should not exceed 1.5 KV during the first 25 microseconds after conduction.

Note 3

The root mean square anode current shall be computed as the square root of the product of the peak current and the average current.

Note 4

The voltage between grid and cathode terminals of the socket with the tube removed should have the following characteristics:

- A. Voltage..... 175-250 Volts
- B. Duration..... 2 Microseconds (at 70% points)
- C. Source of impedance... 1500 Ohms (max.)
- D. Rate of rise..... 200 Volts/microsecond (min.)

The limits of anode time delay and anode time jitter are based on the minimum trigger. Using the highest permissible trigger voltage and lowest trigger source impedance materially reduces these values below the limits specified.

Note 5

The time of anode delay is measured between the 26 percent point on the rising portion of the unloaded grid voltage pulse and the point at which evidence of anode conduction first appears on the loaded grid pulse.

Note 6

Time jitter is measured at the 50 percent point on the anode current pulse.

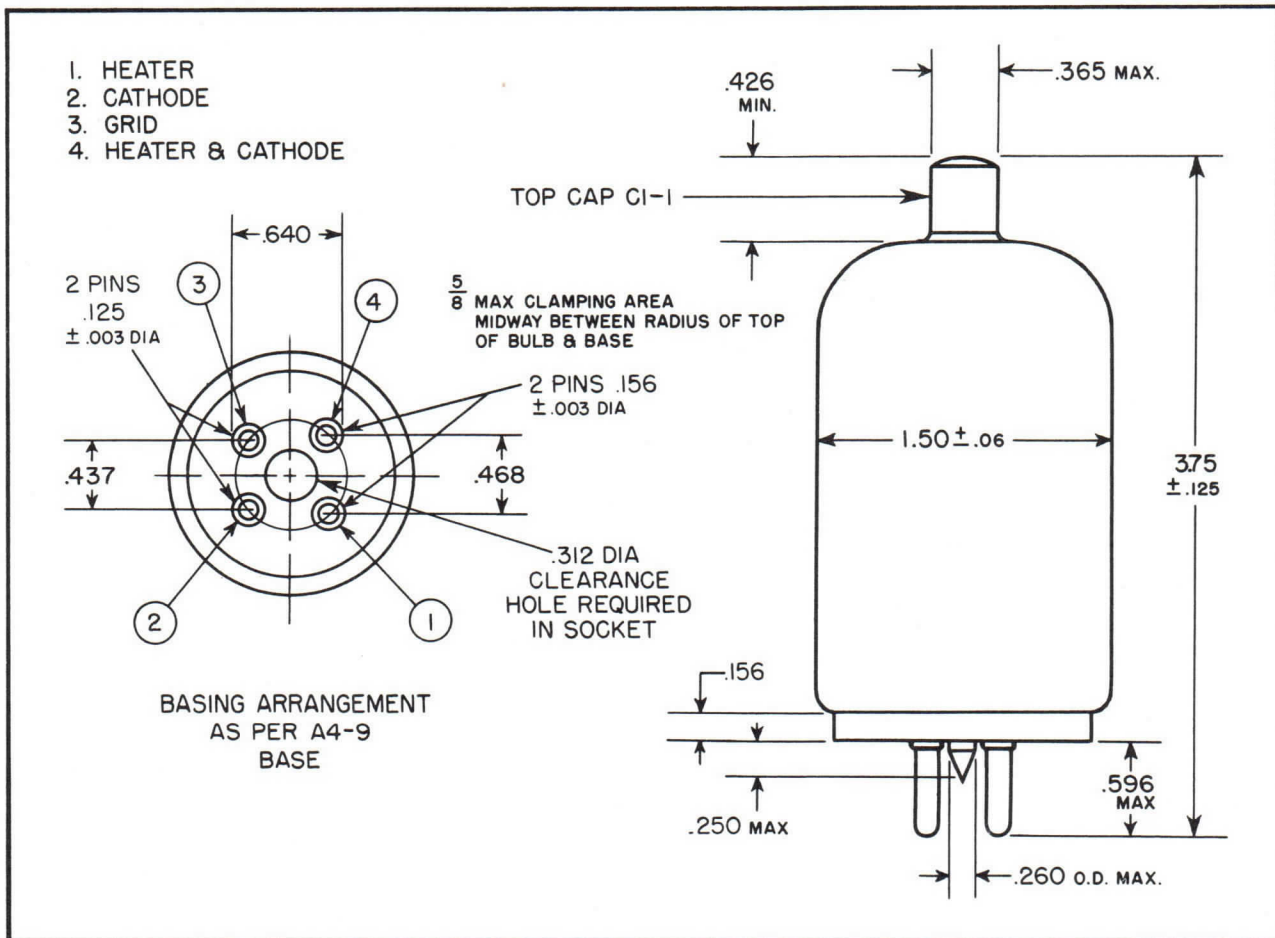

engineering TUBE DATA

Kuthe

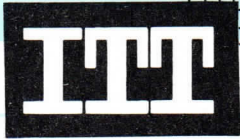

Components Division

TYPE 4C35 HYDROGEN THYRATRON

GENERAL DATA

DESCRIPTION:

The 4C35 is a unipotential cathode, three element hydrogen filled thyatron designed for network discharge service. In such service it is suitable for producing pulse outputs of more than 350 KW at an average power level of more than 400 watts.

The special features of the 4C35 include the high peak current and voltage ratings:

Electrical Data, General	Nom.	Min.	Max.
Heater voltage.....	6.3	5.7	6.6 Volts a.c.
Heater current. $E_h=6.3$ volts.....	5.5	6.7	Amperes
Minimum heating time.....	3		Minutes

Mechanical Data, General

Mounting position.....	Any
Base.....	Super Jumbo 4-pin with bayonet A4-18 with ceramic insert
Anode Cap.....	Medium Metal, C1-5 with corona flare
Cooling.....	Note 1
Net Weight.....	8 Ounces

Dimensions

See outline drawing

Ratings

Max. peak anode voltage, forward...	8.0 Kilovolts
Max. peak anode voltage, inverse (Note 2).....	8.0 Kilovolts
Min. anode supply voltage.....	2.5 Kilovolts d.c.
Max. peak anode current.....	90 Amperes
Max. average anode current.....	100 Milliampers
Max. RMS anode current (Note 3).....	3.0 Amperes a.c.
Max. epy x ib x prr.....	2.0×10^9
Max. anode current rate of rise.....	1000 Amperes/ μ second
Peak trigger voltage.....	Note 4
Max. peak inverse trigger voltage...	200 Volts
Max. anode delay time (Note 5).....	0.60 Microsecond
Max. anode delay time drift.....	0.10 Microsecond
Max. time jitter (Note 6).....	0.01 Microsecond (initial) 0.02 μ second (end of life)
Ambient temperature.....	-50° to $+90^\circ$ Cent.
Shock rating.....	24° Navy (Flyweight) shock machine

**Typical Operation as Pulse Modulator,
DC Resonant Charging**

Peak network voltage.....	8.0 Kilovolts
Pulse repetition rate.....	2800 Pulses/second
Pulse length.....	0.40 Microsecond
Pulse forming network impedance....	46.0 Ohms
Trigger voltage.....	200 Volts
Peak power output (Resistive load 92% Zn).....	330 Kilowatts
Peak anode current.....	89 Amperes
Average anode current.....	0.10 Amperes d.c.

Note 1

Cooling is permitted. However, there shall be no air blast directly on the bulb.

Note 2

In pulsed operation, the peak inverse voltage, exclusive of a spike of 0.05 microsecond maximum duration shall not exceed 2.5 KV during the first 25 microseconds after the pulse.

Note 3

The root mean square anode current shall be computed as

the square root of the product of the peak current and the average current.

Note 4

The voltage between grid and cathode terminals of the socket with the tube removed should have the following characteristics:

- A. Voltage..... 175-250 Volts
- B. Duration..... 2 Microseconds (at 70% points)
- C. Source of impedance. 1500 Ohms (max.)
- D. Rate of rise..... 200 Volts/microsecond (min.)

The limits of anode time delay and anode time jitter are based on the minimum trigger. Using the highest permissible trigger voltage and lowest trigger source impedance materially reduces these values below the limits specified.

Note 5

The time of anode delay is measured between the 26 percent point on the rising portion of the unloaded grid voltage pulse and the point at which evidence of anode conduction first appears on the loaded grid pulse.

Note 6

Time jitter is measured at the 50 percent point on the anode current pulse.

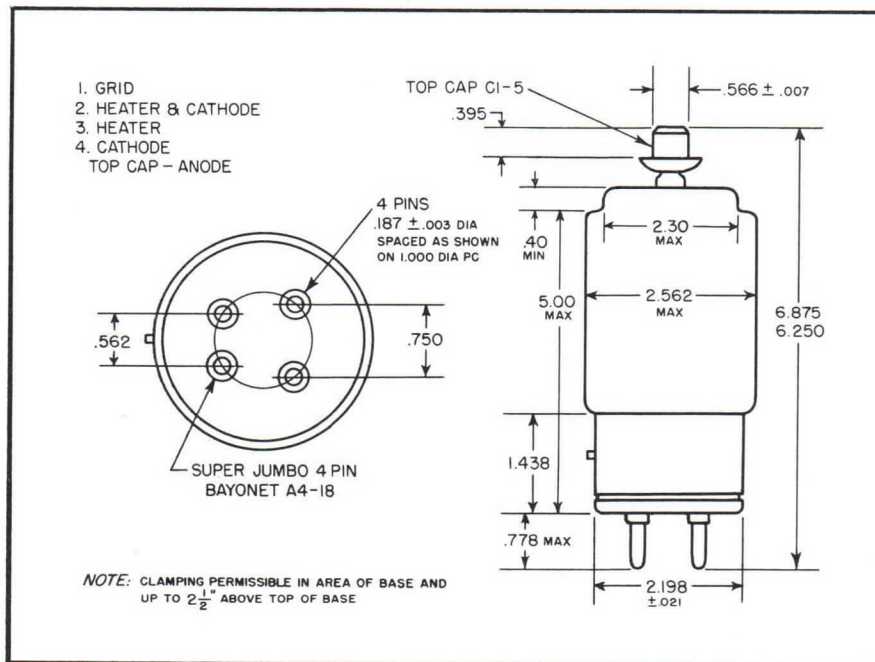

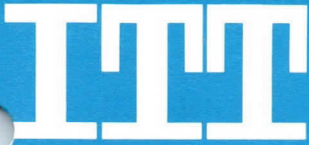

DESCRIPTION:

THE 4C35A IS A UNIPOTENTIAL CATHODE, THREE ELEMENT HYDROGEN FILLED THYRATRON DESIGNED FOR NETWORK DISCHARGE SERVICE. THE SPECIAL FEATURES OF THE 4C35A ARE ITS LOW JITTER AND HIGH POWER OUTPUT. PEAK POWERS OF 350 KILOWATTS ARE REALIZED WITH THIS THYRATRON.

THE HYDROGEN RESERVOIR WITH WHICH THIS TUBE IS EQUIPPED PROVIDES A LONG STABLE OPERATING AND SHELF LIFE.

<u>ELECTRICAL DATA, GENERAL:</u>	<u>NOM.</u>	<u>MIN.</u>	<u>MAX.</u>	
HEATER VOLTAGE	6.3	5.7	6.6	VOLTS A.C.
HEATER CURRENT (AT 6.3 VOLTS)		5.5	6.7	AMPERES
MINIMUM HEATING TIME			3	MINUTES

MECHANICAL DATA, GENERAL:

MOUNTING POSITION	ANY
BASE	SUPER JUMBO 4-PIN WITH BAYONET A4-18 WITH CERAMIC INSERT C1-43, MEDIUM, WITH CORONA SHIELD
ANODE CAP	
COOLING (NOTE 1)	
NET WEIGHT	8 OUNCES
DIMENSIONS	SEE OUTLINE

RATINGS:

MAX. PEAK ANODE VOLTAGE, FORWARD		8.0	KILOVOLTS
MAX. PEAK ANODE VOLTAGE, INVERSE (NOTE 2)		8.0	KILOVOLTS
MIN. ANODE SUPPLY VOLTAGE		2.5	KILOVOLTS D.C.
MAX. PEAK ANODE CURRENT		90	AMPERES
MAX. AVERAGE ANODE CURRENT		100	MILLIAMPERES
MAX. RMS ANODE CURRENT (NOTE 3)		3.0	AMPERES A.C.
MAX. EPY X IB X PRR		2.0 X 10 ⁹	
MAX. ANODE CURRENT RATE OF RISE		1000	AMPERES/USECOND
PEAK TRIGGER VOLTAGE (NOTE 4)			
MAX. PEAK INVERSE TRIGGER VOLTAGE		200	VOLTS
	INITIAL	END OF LIFE	
	LIMIT	LIMIT	
MAX. ANODE DELAY TIME (NOTE 5)	0.6	0.7	MICROSECOND
MAX. ANODE DELAY TIME DRIFT	0.1	0.1	MICROSECOND
MAX. TIME JITTER (NOTE 6)	0.01	0.02	MICROSECOND
AMBIENT TEMPERATURE		-50° to +90°	CENT.
SHOCK RATING		24°	NAVY (FLYWEIGHT) SHOCK MACHINE

TYPICAL OPERATION AS PULSE MODULATOR, DC RESONANT CHARGING:

PEAK NETWORK VOLTAGE	8.0	KILOVOLTS
PULSE REPETITION RATE	2800	PULSES/SECOND
PULSE LENGTH	0.40	MICROSECOND
PULSE FORMING NETWORK IMPEDANCE	46.9	OHMS
TRIGGER VOLTAGE	200	VOLTS
PEAK POWER OUTPUT (RESISTIVE LOAD 92% ZN)	330	KILOWATTS
PEAK ANODE CURRENT	89	AMPERES
AVERAGE ANODE CURRENT	0.10	AMPERES D.C.

NOTE 1:

COOLING PERMITTED. HOWEVER, THERE SHALL BE NO AIR BLAST DIRECTLY ON THE BULB.

NOTE 2:

IN PULSED OPERATION, THE PEAK INVERSE VOLTAGE, EXCLUSIVE OF SPIKE OF 0.05 MICROSECOND MAXIMUM DURATION, SHALL NOT EXCEED 2.5 KV DURING THE FIRST 25 MICROSECONDS AFTER THE PULSE.

NOTE 3:

THE ROOT MEAN SQUARE ANODE CURRENT SHALL BE COMPUTED AS THE SQUARE ROOT OF THE PRODUCT OF THE PEAK CURRENT AND THE AVERAGE CURRENT.

NOTE 4:

THE VOLTAGE BETWEEN GRID AND CATHODE TERMINALS OF THE SOCKET WITH THE TUBE REMOVED SHOULD HAVE THE FOLLOWING CHARACTERISTICS:

- | | |
|------------------------|--------------------------------|
| A. VOLTAGE | 175-250 VOLTS |
| B. DURATION | 2 MICROSECONDS (AT 70% POINTS) |
| C. SOURCE OF IMPEDANCE | 1500 OHMS (MAX.) |
| D. RATE OF RISE | 200 VOLTS/MICROSECOND |

THE LIMITS OF ANODE TIME DELAY AND ANODE TIME JITTER ARE BASED ON THE MINIMUM TRIGGER. USING THE HIGHEST PERMISSIBLE TRIGGER VOLTAGE AND LOWEST TRIGGER SOURCE IMPEDANCE MATERIALLY REDUCES THESE VALUES BELOW THE LIMITS SPECIFIED.

NOTE 5:

THE TIME OF ANODE DELAY IS MEASURED BETWEEN THE 26 PERCENT POINT ON THE RISING PORTION OF THE UNLOADED GRID VOLTAGE PULSE AND THE POINT AT WHICH EVIDENCE OF ANODE CONDUCTION FIRST APPEARS ON THE LOADED GRID PULSE.

NOTE 6:

TIME JITTER IS MEASURED AT THE 50 PERCENT POINT ON THE ANODE CURRENT PULSE.

ADDITIONAL INFORMATION FOR SPECIFIC APPLICATIONS CAN BE OBTAINED FROM THE

ELECTRON TUBE APPLICATIONS SECTION
ITT COMPONENTS DIVISION
POST OFFICE BOX 412
CLIFTON, NEW JERSEY



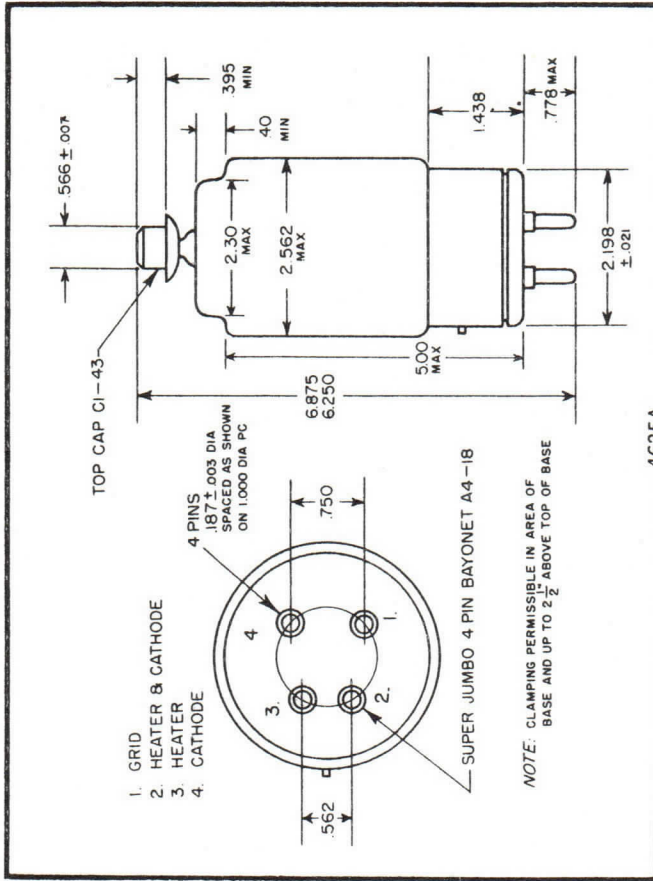

4C35A



DESCRIPTION:

THE 5C22 IS A UNIPOTENTIAL CATHODE, THREE ELEMENT HYDROGEN FILLED THYRATRON DESIGNED FOR NETWORK DISCHARGE SERVICE. IN SUCH SERVICE, IT IS SUITABLE FOR PRODUCING PULSE OUTPUTS OF MORE THAN 2 MEGAWATTS AT AN AVERAGE POWER LEVEL OF MORE THAN 1.6 KW.

THE SPECIAL FEATURES OF THE 5C22 ARE HIGH PEAK VOLTAGE AND CURRENT RATINGS AND THE COMPACT SIZE, LOW TIME JITTER AND THE PRESENCE OF A RESERVOIR, CAPABLE OF MAINTAINING THE HYDROGEN PRESSURE THROUGHOUT THE USEFUL LIFE OF THE TUBE; AN IMPROVED AND STRONGER ENVELOPE TOP SEAL IS INCORPORATED.

ELECTRICAL DATA, GENERAL:

	<u>NOM.</u>	<u>MIN.</u>	<u>MAX.</u>	
HEATER VOLTAGE	6.3	5.9	6.7	VOLTS A.C.
HEATER CURRENT (AT 6.3 VOLTS)		9.6	11.6	AMPERES
MINIMUM HEATING TIME				5 MINUTES

MECHANICAL DATA, GENERAL:

MOUNTING POSITION	ANY
BASE	SUPER JUMBO 4-PIN WITH BAYONET A4-18 WITH CERAMIC INSERT C1-43, MEDIUM, WITH CORONA SHIELD
ANODE CAP	
COOLING (NOTE 1)	
NET WEIGHT	12 OUNCES
DIMENSIONS	SEE OUTLINE

TYPE
5C22
HYDROGEN
THYRATRON

- 2 -

RATINGS:

MAX. PEAK ANODE VOLTAGE, FORWARD	16.0	KILOVOLTS
MAX. PEAK ANODE VOLTAGE, INVERSE (NOTE 2)	16.0	KILOVOLTS
MIN. ANODE SUPPLY VOLTAGE	4.5	KILOVOLTS D.C.
MAX. PEAK ANODE CURRENT	325	AMPERES
MAX. AVERAGE ANODE CURRENT	200	MILLIAMPERES
MAX. RMS ANODE CURRENT (NOTE 3)	6.3	AMPERES A.C.
MAX. EPY X IB X PRR	3.2×10^9	
MAX. ANODE CURRENT RATE OF RISE	1500	AMPERES/USECOND
PEAK TRIGGER VOLTAGE (NOTE 4)		
MAX. PEAK INVERSE TRIGGER VOLTAGE	200	VOLTS

	<u>INITIAL LIMIT</u>	<u>END OF LIFE LIMIT</u>	
MAX. ANODE DELAY TIME (NOTE 5)	0.65	0.70	MICROSECOND
MAX. ANODE DELAY TIME DRIFT	0.10	0.10	MICROSECOND
MAX. TIME JITTER (NOTE 6)	0.005	0.01	MICROSECOND
AMBIENT TEMPERATURE		-50° TO 190°	CENT.
SHOCK RATING		13°	NAVY (FLYWEIGHT) SHOCK MACHINE

TWO TYPICAL OPERATIONS AS PULSE MODULATOR, DC RESONANT CHARGING:

PEAK NETWORK VOLTAGE	16.0	12.0	KILOVOLTS
PULSE REPETITION RATE	1000	500	PULSES/SECOND
PULSE LENGTH	1.0	1.5	MICROSECONDS
PULSE FORMING NETWORK IMPEDANCE	47.6	25	OHMS
TRIGGER VOLTAGE	200	200	VOLTS
PEAK POWER OUTPUT (RESISTIVE LOAD 92% ZN)	1.31	1.40	MEGAWATT
PEAK ANODE CURRENT	175	250	AMPERES
AVERAGE ANODE CURRENT	0.18	0.19	AMPERES D.C.

NOTE 1:

COOLING PERMITTED. HOWEVER, THERE SHALL BE NO AIR BLAST DIRECTLY ON THE BULB.

NOTE 2:

DURING THE FIRST 25 MICROSECONDS AFTER CONDUCTION, THE PEAK INVERSE ANODE VOLTAGE SHALL NOT EXCEED 5 KV.

NOTE 3:

THE ROOT MEAN SQUARE ANODE CURRENT SHALL BE COMPUTED AS THE SQUARE ROOT OF THE PRODUCT OF PEAK CURRENT AND THE AVERAGE CURRENT.

NOTE 4:

THE PULSE PRODUCED BY THE DRIVER CIRCUIT SHALL HAVE THE FOLLOWING CHARACTERISTICS WHEN VIEWED AT THE 5C22 SOCKET WITH THE TUBE DISCONNECTED:

A. AMPLITUDE	200-300 VOLTS
B. DURATION	2 MICROSECONDS (AT 70% POINTS)
C. RATE OF RISE	200 VOLTS/MICROSECOND (MIN.)
D. IMPEDANCE	50-500 OHMS

THE LIMITS OF ANODE TIME DELAY AND ANODE TIME JITTER ARE BASED ON THE MINIMUM TRIGGER. USING THE HIGHEST PERMISSIBLE TRIGGER VOLTAGE AND LOWEST TRIGGER SOURCE IMPEDANCE MATERIALLY REDUCES THESE VALUES BELOW THE LIMITS SPECIFIED.

NOTE 5:

THE TIME OF ANODE DELAY IS MEASURED BETWEEN THE 26 PERCENT POINT ON THE RISING PORTION OF THE UNLOADED GRID VOLTAGE PULSE AND THE POINT AT WHICH EVIDENCE OF ANODE CONDUCTION FIRST APPEARS ON THE LOADED GRID PULSE.

NOTE 6:

TIME JITTER IS MEASURED AT THE 50 PERCENT POINT ON THE ANODE CURRENT PULSE.

ADDITIONAL INFORMATION FOR SPECIFIC APPLICATIONS CAN BE OBTAINED FROM THE -

ELECTRON TUBE APPLICATIONS SECTION
ITT COMPONENTS DIVISION
Post Office Box 412
CLIFTON, NEW JERSEY



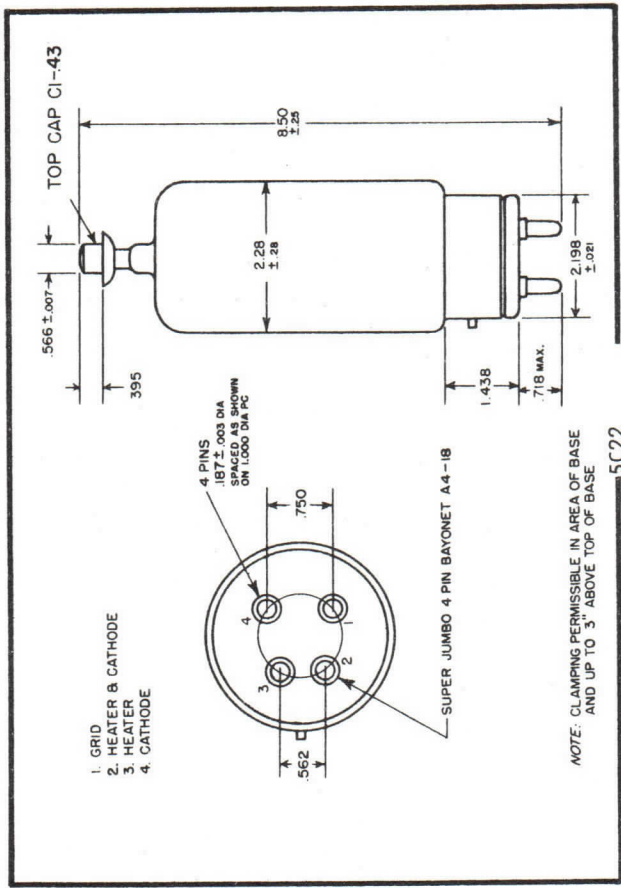

NOTE: CLAMPING PERMISSIBLE IN AREA OF BASE AND UP TO 3" ABOVE TOP OF BASE

5C22

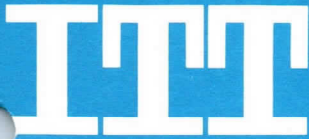

DESCRIPTION:

THE KU-25 IS A UNIPOTENTIAL CATHODE, 3 ELEMENT HYDROGEN FILLED THYRATRON DESIGNED FOR NETWORK DISCHARGE SERVICE. IN SUCH SERVICE, IT IS SUITABLE FOR PRODUCING PULSE OUTPUTS OF MORE THAN 1.5 MEGAWATTS AT AN AVERAGE POWER LEVEL OF MORE THAN 1.2 KW.

THE KU-25 IS EQUIPPED WITH RESERVOIR FOR LONG STABLE LIFE AND IS ESPECIALLY ADAPTED TO OPERATION AT HIGH PULSE REPETITION RATES.

ELECTRICAL DATA, GENERAL:

	<u>NOM.</u>	<u>MIN.</u>	<u>MAX.</u>	
HEATER VOLTAGE	6.3	5.9	6.7	VOLTS A.C.
HEATER CURRENT (AT 6.3 VOLTS)		9.6	11.6	AMPERES
MINIMUM HEATING TIME				5 MINUTES

MECHANICAL DATA, GENERAL:

MOUNTING POSITION	ANY
BASE	SUPER JUMBO 4-PIN WITH BAYONET A4-18 WITH CERAMIC INSERT C1-43, MEDIUM, WITH CORONA SHIELD
ANODE CAP	
COOLING (NOTE 1)	
NET WEIGHT	12 OUNCES
DIMENSIONS	SEE OUTLINE

RATINGS:

MAX. PEAK ANODE VOLTAGE, FORWARD	12.0	KILOVOLTS
MAX. PEAK ANODE VOLTAGE, INVERSE (NOTE 2)	12.0	KILOVOLTS
MIN. ANODE SUPPLY VOLTAGE	3.5	KILOVOLTS D.C.
MAX. PEAK ANODE CURRENT	300	AMPERES
MAX. AVERAGE ANODE CURRENT	200	MILLIAMPERES
MAX. RMS ANODE CURRENT (NOTE 3)	7.75	AMPERES A.C.
MAX. EPY X IB X PRR	3.8×10^9	
MAX. ANODE CURRENT RATE OF RISE	1250	AMPERES/ μ SECOND
PEAK TRIGGER VOLTAGE (NOTE 4)		
MAX. PEAK INVERSE TRIGGER VOLTAGE	200	VOLTS
MAX. ANODE DELAY TIME (NOTE 5)	1.0	MICROSECOND
MAX. ANODE DELAY TIME DRIFT	0.15	MICROSECOND
MAX. TIME JITTER (NOTE 6)	0.05	MICROSECOND
AMBIENT TEMPERATURE	-50° TO 90°	CENT.
SHOCK RATING	13°	NAVY (FLYWEIGHT) SHOCK MACHINE

TYPICAL OPERATION AS PULSE MODULATOR, DC RESONANT CHARGING:

PEAK NETWORK VOLTAGE	12.0	KILOVOLTS
PULSE REPETITION RATE	2500	PULSES/SECOND
PULSE LENGTH	0.4	MICROSECOND
PULSE FORMING NETWORK IMPEDANCE	48	OHMS
TRIGGER VOLTAGE	200	VOLTS
PEAK POWER OUTPUT (RESISTIVE LOAD 92% ZN)	736	KILOWATTS
PEAK ANODE CURRENT	130	AMPERES
AVERAGE ANODE CURRENT	0.13	AMPERES D.C.

NOTE 1:

COOLING PERMITTED. HOWEVER, THERE SHALL BE NO AIR BLAST DIRECTLY ON THE BULB.

NOTE 2:

DURING THE FIRST 25 MICROSECONDS AFTER CONDUCTION, THE PEAK INVERSE ANODE VOLTAGE SHALL NOT EXCEED 5.0 KV.

NOTE 3:

THE ROOT MEAN SQUARE ANODE CURRENT SHALL BE COMPUTED AS THE SQUARE ROOT OF THE PRODUCT OF THE PEAK CURRENT AND THE AVERAGE CURRENT.

NOTE 4:

THE PULSE PRODUCED BY THE DRIVER CIRCUIT SHALL HAVE THE FOLLOWING CHARACTERISTICS WHEN VIEWED AT THE KU-25 SOCKET WITH THE GRID OF THE TUBE DISCONNECTED:

A. VOLTAGE	200-300 VOLTS
B. DURATION	2 MICROSECONDS (AT 70% POINTS)
C. RATE OF RISE	200 VOLT/MICROSECOND (MIN.)
D. IMPEDANCE	50-500 OHMS (MAX.)

THE LIMITS OF ANODE TIME DELAY AND ANODE TIME JITTER ARE BASED ON THE MINIMUM TRIGGER. USING THE HIGHEST PERMISSIBLE TRIGGER VOLTAGE AND LOWEST TRIGGER SOURCE IMPEDANCE MATERIALLY REDUCES THESE VALUES BELOW THE LIMITS SPECIFIED.

NOTE 5:

THE TIME OF ANODE DELAY IS MEASURED BETWEEN THE 26 PERCENT POINT ON THE RISING PORTION OF THE UNLOADED GRID VOLTAGE PULSE AND THE POINT AT WHICH EVIDENCE OF ANODE CONDUCTION FIRST APPEARS ON THE LOADED GRID PULSE.

NOTE 6:

TIME JITTER IS MEASURED AT THE 50 PERCENT POINT ON THE ANODE CURRENT PULSE.

ADDITIONAL INFORMATION FOR SPECIFIC APPLICATIONS CAN BE OBTAINED FROM THE

ELECTRON TUBE APPLICATIONS SECTION
ITT COMPONENTS DIVISION
Post Office Box 412
CLIFTON, NEW JERSEY



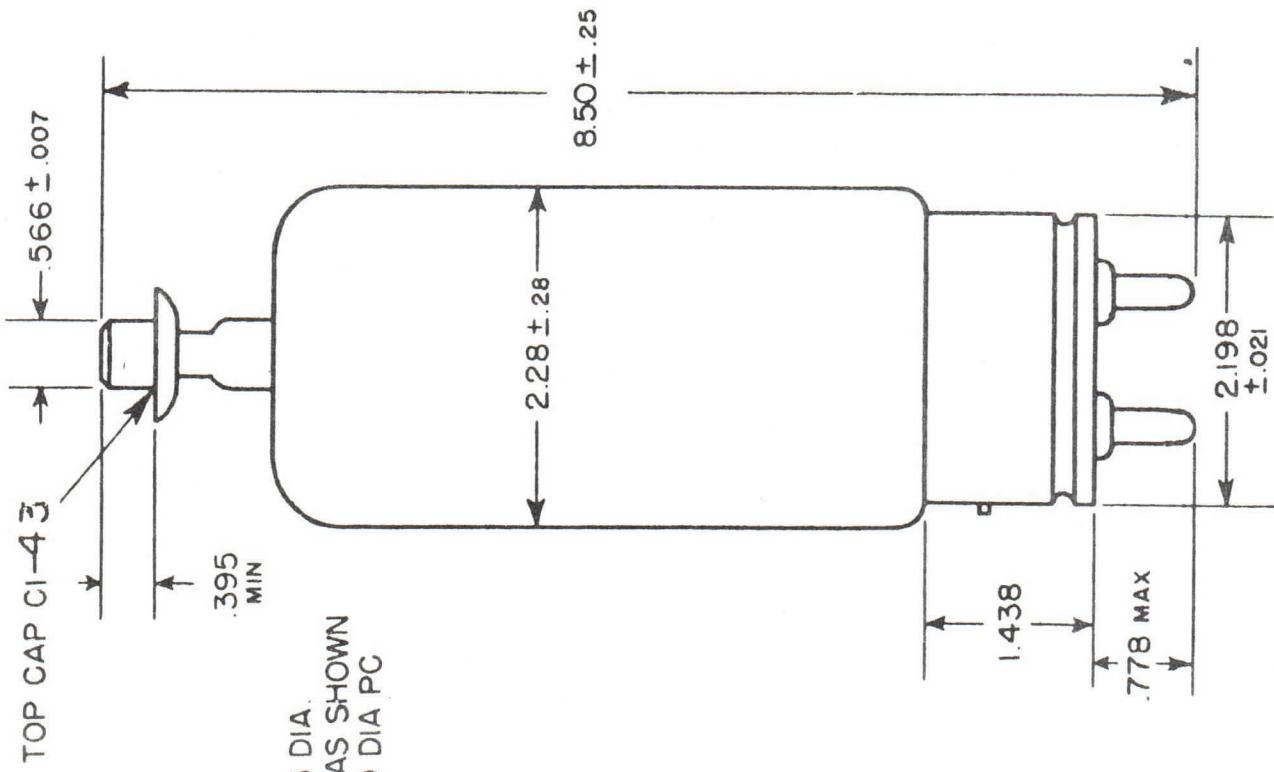

- 1. GRID
- 2. HEATER & CATHODE
- 3. HEATER
- 4. CATHODE
- TOP CAP - ANODE

4 PINS
187 ± .003 DIA.
SPACED AS SHOWN
ON 1.000 DIA PC

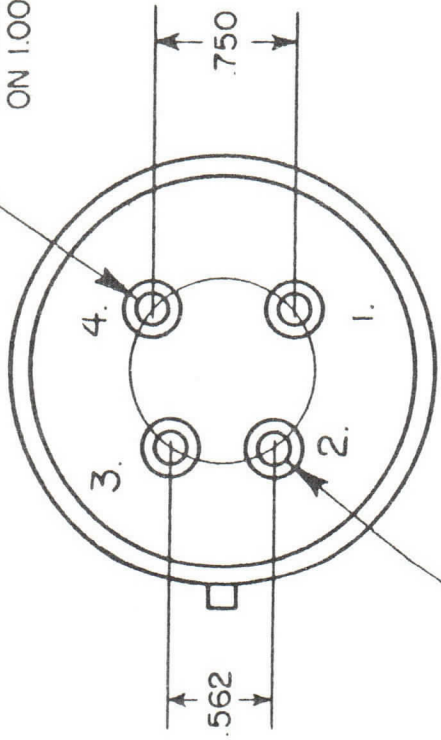

SUPER JUMBO 4PIN
BAYONET A4-18

NOTE: CLAMPING PERMISSIBLE IN AREA OF
BASE AND UP TO 3" ABOVE TOP OF BASE

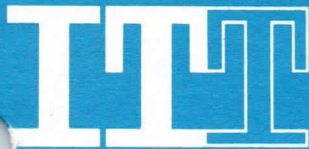

T E N T A T I V E

DESCRIPTION:

THE E-38 IS A UNIPOTENTIAL CATHODE THREE ELEMENT HYDROGEN THYRATRON. AN ELECTRICALLY HEATED TITANIUM HYDRIDE RESERVOIR IS CONNECTED INTERNALLY ACROSS THE CATHODE HEATERS. THE E-38 WAS DEVELOPED TO MEET THE NEEDS OF THE MODULATOR DESIGNER FOR A LOW PLATE VOLTAGE THYRATRON FOR OPERATION AT A HIGH DUDY CYCLE.

ELECTRICAL DATA, GENERAL:

	<u>Nom.</u>	<u>Min.</u>	<u>Max.</u>	
HEATER VOLTAGE	6.3	5.7	6.6	VOLTS AC
HEATER CURRENT (AT 6.3 VOLTS)		5.5	6.7	AMPERES
MINIMUM HEATING TIME				3 MINUTES

MECHANICAL DATA, GENERAL:

MOUNTING POSITION		ANY
BASE		PER OUTLINE
COOLING (NOTE 1)		
NET WEIGHT	0.3	POUNDS
DIMENSIONS		PER OUTLINE

RATINGS:

MAX. PEAK ANODE VOLTAGE, FORWARD	5.0	KILOVOLTS
MAX. PEAK ANODE VOLTAGE, INVERSE (NOTE 2)	5.0	KILOVOLTS
MIN. ANODE SUPPLY VOLTAGE	0.3	KILOVOLTS DC
MAX. PEAK ANODE CURRENT	85	AMPERES
MAX. AVERAGE ANODE CURRENT	100	MILLIAMPERES
MAX. RMS ANODE CURRENT (NOTE 3)	2.9	AMPERES AC
MAX. EPY X IB X PRR	2.5	$\times 10^9$
MAX. ANODE CURRENT RATE OF RISE	1200	AMPS / U SEC.
PEAK TRIGGER VOLTAGE (NOTE 4)		
MAX. ANODE DELAY TIME (NOTE 5)	0.6	MICROSECOND
MAX. ANODE DELAY TIME DRIFT	0.15	MICROSECOND
MAX. TIME JITTER (NOTE 6)	0.01	MICROSECOND
AMBIENT TEMPERATURE	-50° to / 90°	C

NOTE 1:

COOLING OF THE ANODE LEAD IS PERMISSIBLE, BUT THERE SHALL BE NO AIR BLAST DIRECTLY ON THE BULB.

NOTE 2:

IN PULSED OPERATION, THE PEAK INVERSE VOLTAGE, EXCLUSIVE OF SPIKE OF .05 US MAXIMUM DURATION, SHALL NOT EXCEED 2000 V DURING THE FIRST 25 US AFTER THE PULSE.

NOTE 3:

THE ROOT MEAN SQUARE ANODE CURRENT SHALL BE COMPUTED AS THE SQUARE ROOT OF THE PRODUCT OF PEAK CURRENT AND THE AVERAGE CURRENT.

NOTE 4:

DRIVER PULSE, MEASURED AT TUBE SOCKET WITH THYRATRON GRID DISCONNECTED; EGY = 175 V (MIN.), TIME OF RISE = 0.5 US (MAX.), GRID PULSE DURATION = 2 US (MIN.), IMPEDANCE OF DRIVER CIRCUIT = 1500 OHMS (MAX.).

NOTE 5:

THE TIME OF ANODE DELAY IS MEASURED BETWEEN THE 26 PER CENT POINT ON THE RISING PORTION OF THE UNLOADED GRID VOLTAGE PULSE AND THE POINT AT WHICH ANODE CONDUCTION FIRST EVIDENCES ITSELF ON THE LOADED GRID PULSE.

NOTE 6:

TIME JITTER IS MEASURED AT THE 50 PER CENT POINT ON THE ANODE CURRENT PULSE.

ADDITIONAL INFORMATION FOR SPECIFIC APPLICATIONS CAN BE OBTAINED FROM THE

ELECTRON TUBE APPLICATIONS SECTION
ITT COMPONENTS DIVISION
POST OFFICE BOX 412
CLIFTON, NEW JERSEY

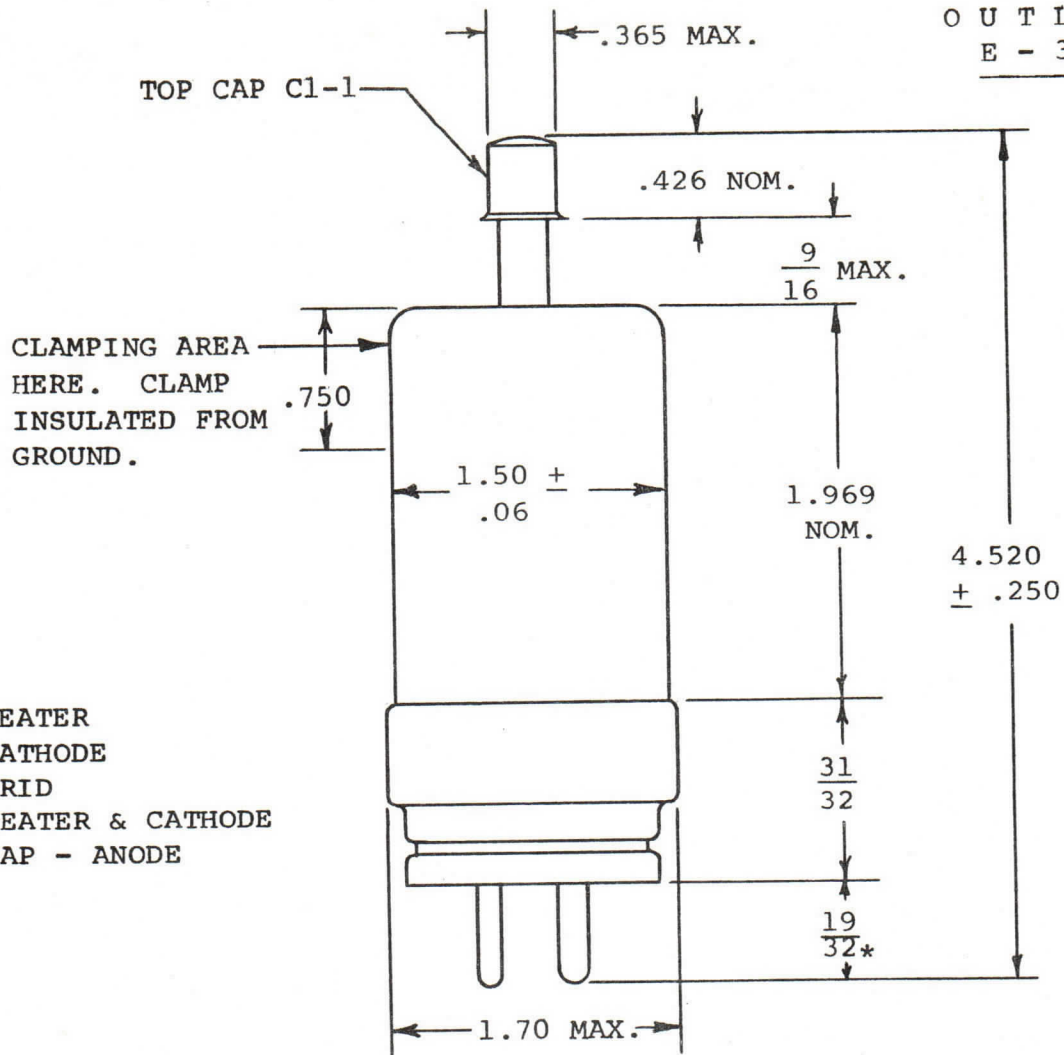

- 1. HEATER
 - 2. CATHODE
 - 3. GRID
 - 4. HEATER & CATHODE
- TOP CAP - ANODE

*ON FINISHED TUBE ADD .030
FOR SOLDER

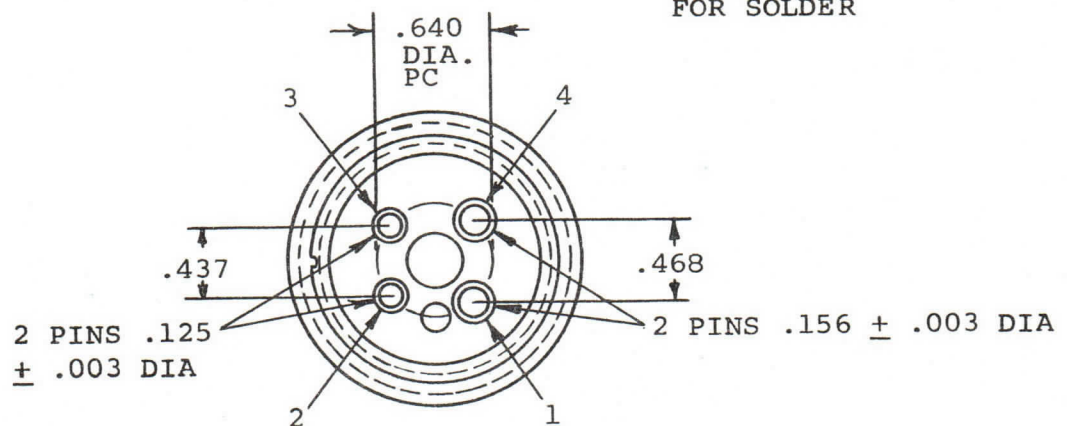

PIN ARRANGEMENT AND DIMENSIONS ONLY
AS PER A4-9 MIL-E-1C



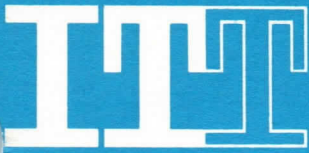

T E N T A T I V E

CERAMIC HYDROGEN THYRATRON

DESCRIPTION:

THE KU-70B IS A UNIPOTENTIAL CATHODE THREE ELEMENT HYDROGEN THYRATRON OF CERAMIC METAL CONSTRUCTION DESIGNED FOR USE IN COMPACT MODULATORS FOR HIGH PERFORMANCE RADARS AND FOR MISSILE APPLICATIONS.

ELECTRICAL DATA, GENERAL:

	<u>NOM.</u>	<u>MIN.</u>	<u>MAX.</u>	
HEATER VOLTAGE	6.3	5.8	6.8	VOLTS AC
* HEATER CURRENT (AT 6.3 VOLTS)		2.0	3.2	AMPERES
MINIMUM HEATING TIME				30 SECONDS

MECHANICAL DATA, GENERAL:

MOUNTING POSITION ANY
DIMENSIONS PER OUTLINE

RATINGS:

MAX. PEAK ANODE VOLTAGE, FORWARD	8.0	KILOVOLTS
MAX. PEAK ANODE VOLTAGE, INVERSE (NOTE 1)	8.0	KILOVOLTS
MIN. ANODE SUPPLY VOLTAGE	0.3	KILOVOLTS DC
MAX. PEAK ANODE CURRENT	100	AMPERES
MAX. AVERAGE ANODE CURRENT	100	MILLIAMPERES
MAX. RMS ANODE CURRENT (NOTE 2)	2.0	AMPERES AC
MAX. EBY X IBX X PRR (PB)	2.7×10^9	
MAX. ANODE CURRENT, RATE OF RISE	1000	AMPS./U SEC.
PEAK TRIGGER VOLTAGE (NOTE 3)		
MAX. PEAK INVERSE TRIGGER VOLTAGE	300	VOLTS
MAX. ANODE DELAY TIME (NOTE 4)	0.50	U SECOND
MAX. ANODE DELAY TIME DRIFT	0.10	U SECOND
MAX. TIME JITTER (NOTE 5)	.005	U SECOND
AMBIENT TEMPERATURE	-65 to +150°	C
SHOCK RATING	200	G.
VIBRATION	20	G.

* INDICATES CHANGE FROM DATA SHEET DATED 6-61

NOTE 1:

THE PEAK INVERSE VOLTAGE SHOULD NOT EXCEED 2.5 KV DURING THE FIRST 25 MICROSECONDS AFTER THE PULSE.

NOTE 2:

THE ROOT MEAN SQUARE ANODE CURRENT SHALL BE COMPUTED AS THE SQUARE ROOT OF THE PRODUCT OF THE PEAK CURRENT AND THE AVERAGE CURRENT.

NOTE 3:

THE DRIVER PULSE, MEASURED AT THE TUBE SOCKET WITH THE THYRATRON GRID DISCONNECTED SHOULD HAVE THE FOLLOWING CHARACTERISTICS:

- | | |
|-----------------|---------------------------------------|
| A. VOLTAGE | 150 VOLTS (MIN.) TO 300 VOLTS (MAX.) |
| B. DURATION | 2 MICROSECONDS (AT 70 PERCENT POINTS) |
| C. IMPEDANCE | 1500 OHMS (MAX.) |
| D. TIME OF RISE | 0.5 MICROSECOND (MAX.) |

THE LIMITS OF ANODE TIME DELAY AND ANODE TIME JITTER ARE BASED ON THE MINIMUM TRIGGER. USING THE HIGHEST PERMISSIBLE TRIGGER VOLTAGE AND LOWEST TRIGGER SOURCE IMPEDANCE MATERIALLY REDUCES THESE VALUES BELOW THE LIMITS SPECIFIED.

NOTE 4:

THE TIME OF ANODE DELAY IS MEASURED BETWEEN THE 26 PERCENT POINT ON THE RISING PORTION OF THE UNLEADED GRID VOLTAGE PULSE AND THE POINT AT WHICH EVIDENCE OF ANODE CONDUCTION FIRST APPEARS ON THE LOADED GRID PULSE.

NOTE 5:

TIME JITTER IS MEASURED AT THE 50 PERCENT POINT ON THE ANODE CURRENT PULSE.

ADDITIONAL INFORMATION FOR SPECIFIC APPLICATIONS CAN BE OBTAINED FROM THE

ELECTRON TUBE APPLICATIONS SECTION
ITT COMPONENTS DIVISION
Post Office Box 412
CLIFTON, NEW JERSEY

OUTLINE

KU-70B

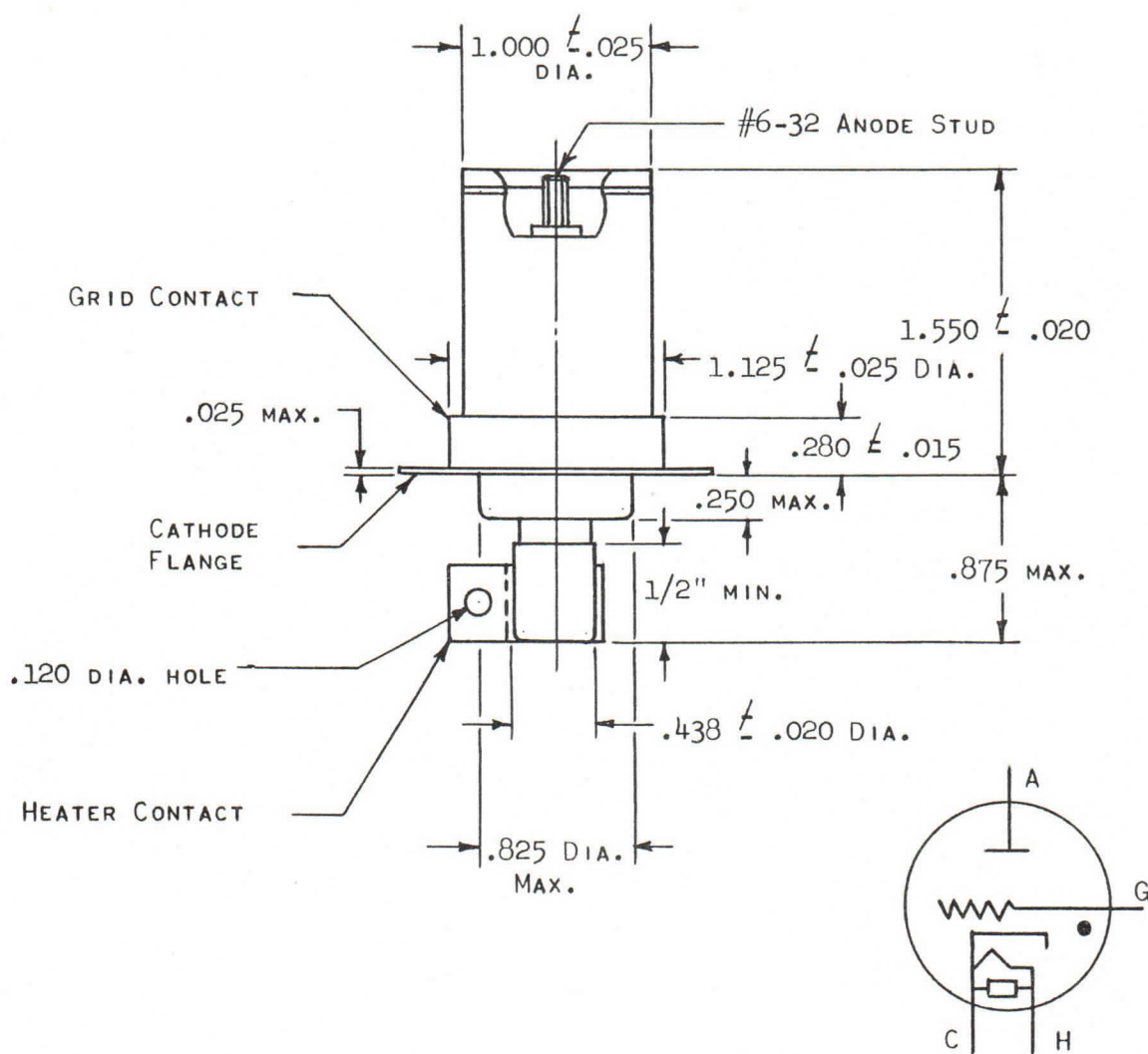
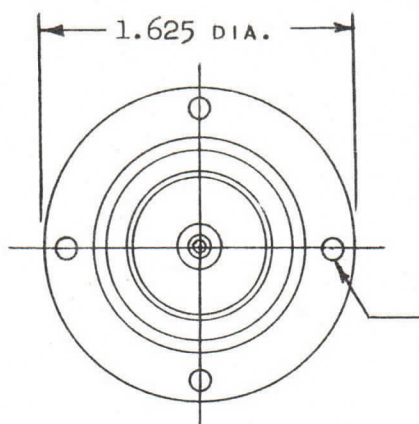



TENTATIVE

CERAMIC HYDROGEN DIODE

DESCRIPTION:

THE KU-93 IS A CERAMIC ENVELOPE, INDIRECTLY HEATED, HYDROGEN FILLED DIODE FOR USE IN HIGH VOLTAGE RECTIFIER AND CLIPPER CIRCUITS. THIS TUBE, EQUIPPED WITH A HYDROGEN RESERVOIR WILL GIVE EXCELLENT SERVICE UNDER SEVERE ENVIRONMENTAL CONDITIONS.

THE INHERENT IMMUNITY FROM ELECTRICAL SURGE DAMAGE, AND RUGGED PHYSICAL CONSTRUCTION SUIT THIS DIODE TO COMPACT HIGH POWER RECTIFIERS AND MODULATORS.

ELECTRICAL DATA, GENERAL:

	<u>NOM.</u>	<u>MIN.</u>	<u>MAX.</u>	
HEATER VOLTAGE	5.0	4.7	5.3	VOLTS AC
HEATER CURRENT (AT 5.0 VOLTS)		15.0	27.0	AMPERES
HEATER (NOTE 1)				
RESERVOIR VOLTAGE (NOTE 2)	5.0	4.7	5.8	VOLTS
RESERVOIR CURRENT AT 5.0 VOLTS		3.5	5.5	AMPERES
MINIMUM HEATING TIME				5 MINUTES

MECHANICAL DATA, GENERAL:

MOUNTING POSITION	VERTICAL ONLY,	BASE DOWN
BASE		PER OUTLINE
COOLING (NOTE 3)		
NET WEIGHT	3.0	POUNDS
DIMENSIONS (SEE OUTLINE DRAWING)		

MAXIMUM RATINGS:

	<u>RECTIFIER</u>	<u>CLIPPER</u>	<u>BACK SWING DIODE</u>	
PEAK INVERSE ANODE VOLTAGE	20.0	30.0	30.0	KILOVOLTS
PEAK ANODE CURRENT	8.0	500	500	AMPERES
AVERAGE ANODE CURRENT	2.0	1.0	2.0	AMPERES
R.M.S. ANODE CURRENT (NOTE 4)	4.0	15.0	15.0	AMPERES
ANODE VOLTAGE DROP	70	500		VOLTS
INITIAL FIRING VOLTAGE (NOTE 5)	100			VOLTS
RECURRENT FIRING VOLTAGE	60			VOLTS
AMBIENT TEMPERATURE	- 55° TO / 125°			CENTIGRADE

NOTE 1:

SEE OUTLINE DRAWING.

NOTE 2:

THE OPTIMUM RESERVOIR VOLTAGE FOR RECTIFIER AND PULSE TRANSFORMER BACK SWING CLIPPER SERVICE IS 5.0 VOLTS. THIS MAY BE OBTAINED BY DIRECT CONNECTION TO THE CATHODE HEATER SUPPLY. FOR USE IN CERTAIN TYPES OF INVERSE CLIPPER SERVICE, A RESERVOIR VOLTAGE SOMEWHAT HIGHER OR LOWER MAY BE REQUIRED (ERES 4.0 - 6.0 VOLTS).

NOTE 3:

AIR BLAST COOLING (10 CFM) IS RECOMMENDED ABOUT THE BASE AND ANODE FOR OPERATION IN HIGH AMBIENT TEMPERATURE.

NOTE 4:

THE ROOT MEAN SQUARE ANODE CURRENT SHALL BE COMPUTED AS THE SQUARE ROOT OF THE PRODUCT OF PEAK CURRENT AND THE AVERAGE CURRENT.

NOTE 5:

IT IS RECOMMENDED THAT THE BAFFLE BE LEFT FLOATING FOR RECTIFIER SERVICE. THE BAFFLE SHOULD BE CONNECTED TO THE CATHODE FOR CLIPPER SERVICE.

ADDITIONAL INFORMATION FOR SPECIFIC APPLICATIONS CAN BE OBTAINED FROM THE

ELECTRON TUBE APPLICATIONS SECTION
ITT ELECTRON TUBE DIVISION
POST OFFICE BOX 104
CLIFTON, NEW JERSEY

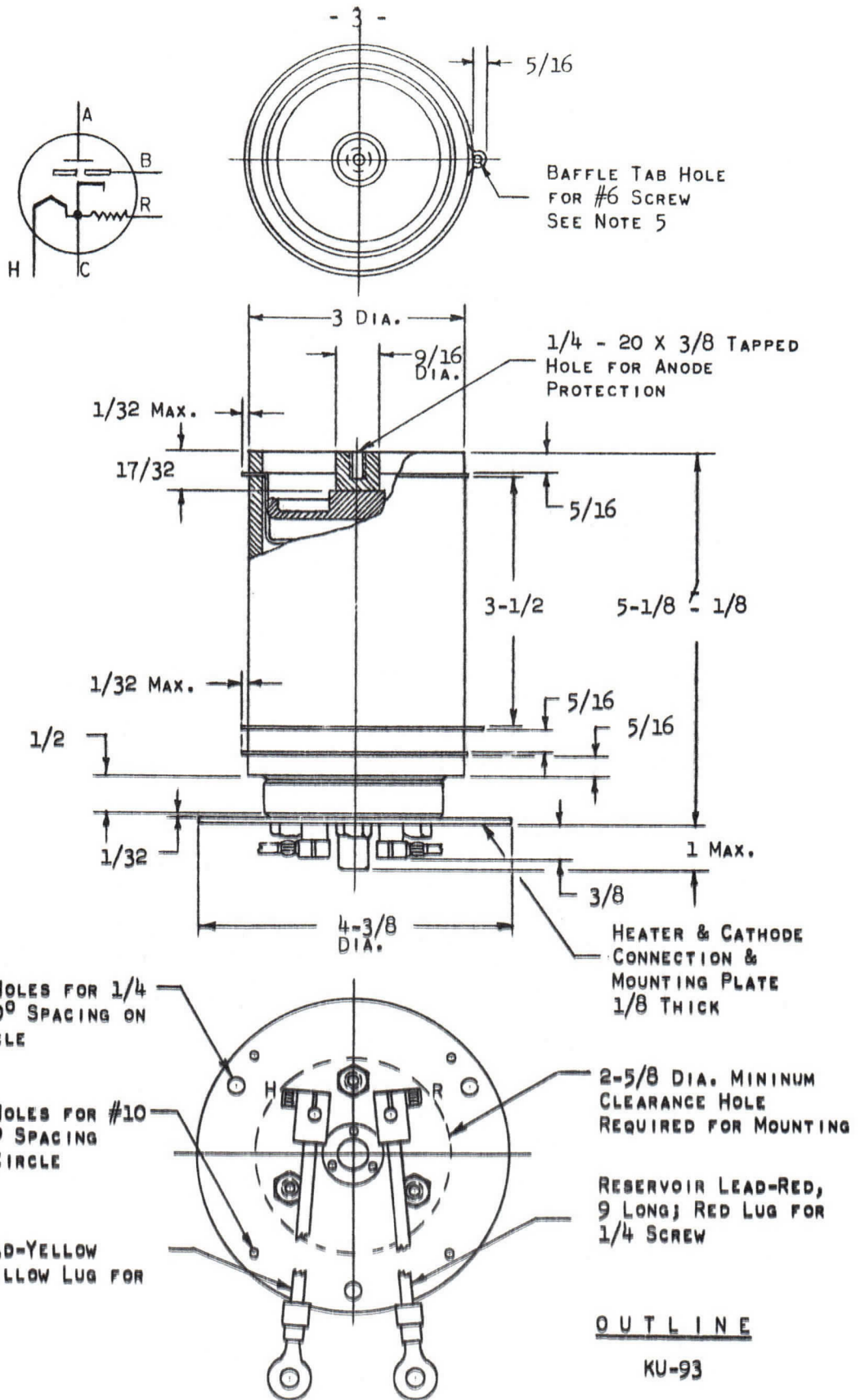

ELECTRON TUBE DIVISION

CLIFTON, NEW JERSEY

INTERNATIONAL TELEPHONE AND TELEGRAPH CORPORATION



T E N T A T I V E

CERAMIC HYDROGEN DIODE

DESCRIPTION:

THE KU-94 IS A CERAMIC ENVELOPE HYDROGEN FILLED DIODE. THIS TUBE IS DESIGNED FOR RECTIFIER AND PULSE TRANSFORMER BACKSWING DIODE CLIPPER APPLICATIONS. THE LOW TUBE VOLTAGE DROP AND WIDE RANGE OF AMBIENT OPERATING TEMPERATURES, IDEALLY SUIT THIS TUBE TO THE ENVIRONMENTS ENCOUNTERED IN MILITARY EQUIPMENT.

ELECTRICAL DATA, GENERAL:

	<u>NOM.</u>	<u>MIN.</u>	<u>MAX.</u>	
HEATER VOLTAGE	5.0	4.7	5.3	VOLTS AC
* HEATER CURRENT (AT 5.0 VOLTS) HEATER (NOTE 1)		18.0	28.0	AMPERES
RESERVOIR VOLTAGE (NOTE 2)		4.7	5.3	VOLTS
RESERVOIR CURRENT AT 5.0 VOLTS		5.0	20.0	AMPERES
MINIMUM HEATING TIME				5 MINUTES

MECHANICAL DATA, GENERAL:

MOUNTING POSITION VERTICAL ONLY, BASE DOWN
 BASE (PER OUTLINE)
 COOLING (NOTE 3)
 NET WEIGHT 11.5 POUNDS
 DIMENSIONS (SEE OUTLINE DRAWING)

MAXIMUM RATINGS:

	<u>RECTIFIER</u>	<u>CLIPPER</u>	<u>BACK SWING DIODE</u>	
PEAK INVERSE ANODE VOLTAGE	26.0	0	33.0	KILOVOLTS
PEAK ANODE CURRENT	15.0	P	2000	AMPERES
AVERAGE ANODE CURRENT	4.5	E	3.0	AMPERES
R.M.S. ANODE CURRENT	-	N	60	AMPERES
ANODE VOLTAGE DROP	70	-	-	VOLTS
INITIAL FIRING VOLTAGE (NOTE 4)	100	-	-	VOLTS
RECURRENT FIRING VOLTAGE	60	-	-	VOLTS
AMBIENT TEMPERATURE	- 55 TO / 125			DEGREES C

* INDICATES CHANGE FROM DATA SHEET DATED 6-61

KUTHE
KU-94

- 2 -

NOTE 1:

CATHODE CONNECTED TO CENTER OF CATHODE HEATER.

NOTE 2:

THE OPTIMUM RESERVOIR VOLTAGE FOR RECTIFIER AND PULSE TRANSFORMER BACK SWING CLIPPER SERVICE IS 5.0 VOLTS. THIS MAY BE OBTAINED BY DIRECT CONNECTION TO THE CATHODE HEATER SUPPLY. FOR USE IN CERTAIN TYPES OF INVERSE CLIPPER SERVICE, A RESERVOIR VOLTAGE SOMEWHAT HIGHER OR LOWER MAY BE REQUIRED (ERES = 4.0 -6.0 VOLTS).

NOTE 3:

AIR BLAST COOLING (10 CFM) IS RECOMMENDED ABOUT THE BASE AND ANODE FOR OPERATION IN HIGH AMBIENT TEMPERATURES.

NOTE 4:

IT IS RECOMMENDED THAT THE BAFFLE BE LEFT FLOATING FOR RECTIFIER SERVICE. THE BAFFLE SHOULD BE CONNECTED TO THE CATHODE FOR CLIPPER SERVICE.

ADDITIONAL INFORMATION FOR SPECIFIC APPLICATIONS CAN BE OBTAINED FROM THE

ELECTRON TUBE APPLICATIONS SECTION
ITT COMPONENTS DIVISION
POST OFFICE BOX 412
CLIFTON, NEW JERSEY

KU-94

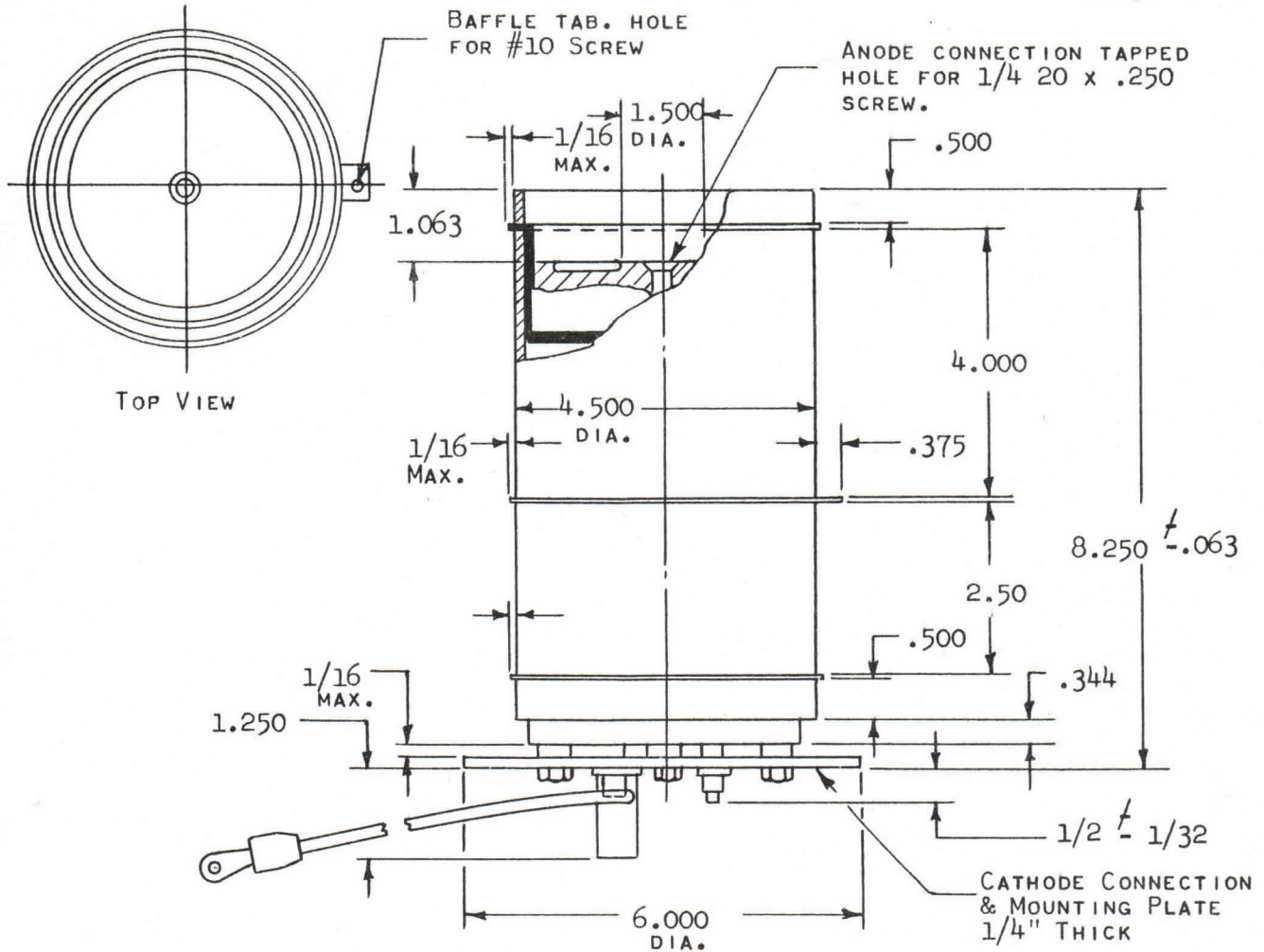

CATHODE HEATER LEAD
10" LONG, YELLOW LUG
FOR 1/4" SCREW

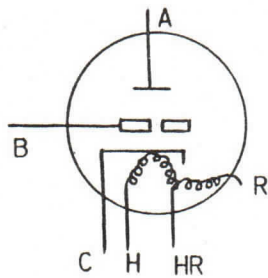

RESERVOIR LEAD
10" LONG, RED,
LUG FOR 1/4"
SCREW

HEATER-RESERVOIR
LEAD 10" LONG, YEL-
LOW, BLACK SLEEVE
LUG FOR 1/4"
SCREW.

(4) MTG. HOLES FOR 1/4"
SCREW 90° SPACING ON
5.344 ± .020 DIA. CIRCLE



CROWBAR THYRATRON

DESCRIPTION:

The type KU-471 is a ceramic hydrogen thyatron designed for Crowbar service. This tube is equipped with a hydrogen reservoir for maximum dependability.

ELECTRICAL DATA, GENERAL:

	<u>Nom.</u>	<u>Min.</u>	<u>Max.</u>	
Heater Voltage	6.3	5.8	6.8	Volts AC
Heater Current (at 6.3 volts)	5.5	3.5	7.0	Amperes
Reservoir Voltage (Note 1)		2.5	6.3	Volts
Reservoir Current		1.0	2.0	Amperes
Minimum Heating Time			3	Minutes

MECHANICAL DATA, GENERAL:

Mounting Position				Any
Base				See Outline
Cooling (Note 2)				
Net Weight			0.3	Pounds
Dimensions				Per Outline

RATINGS:

Max. Peak Anode Voltage, Forward, Transient (Note 3)			20.0	Kilovolts
Max. Peak Anode Voltage, Forward, Operating			16.0	Kilovolts
Max. Peak Anode Voltage, Inverse			16.0	Kilovolts
Min. Anode Supply Voltage			0.5	Kilovolts DC
Max. Peak Anode Current (Note 4)			250	Amperes
Averaging Time			10	Seconds
Max. Discharge Time (Note 4)			0.1	Seconds
Peak Trigger Voltage (Note 5)				
Max. Anode Delay Time			1.0	Microseconds
Ambient Temperature		-55° to + 100°		C

Note 1:

Adjust reservoir voltage to value indicated on tube within $\pm 5\%$.

Note 2:

No cooling required.

Note 3:

The maximum peak forward transient anode voltage rating applies to a transient voltage condition wherein the duration of the transient does not exceed two seconds.

Note 4:

The allowable time of discharge varies with the current as shown:

Rectifier Short Circuit Period	1.5 - 100 ms	5 A
" " " "	1.5 - 50 ms	10 A
" " " "	1.5 - 30 ms	20 A
Filter Discharge	" 0 - 1.5 ms	250 A

Time will be measured from the initiation of the discharge.

Note 5:

The driver pulse measured at the tube socket with the thyatron grid disconnected shall be: $e_{gy} = 200$ Volts minimum; $t_p = 2.0$ Microseconds minimum; impedance of driver circuit 50 - 500 Ohms.

KU-471

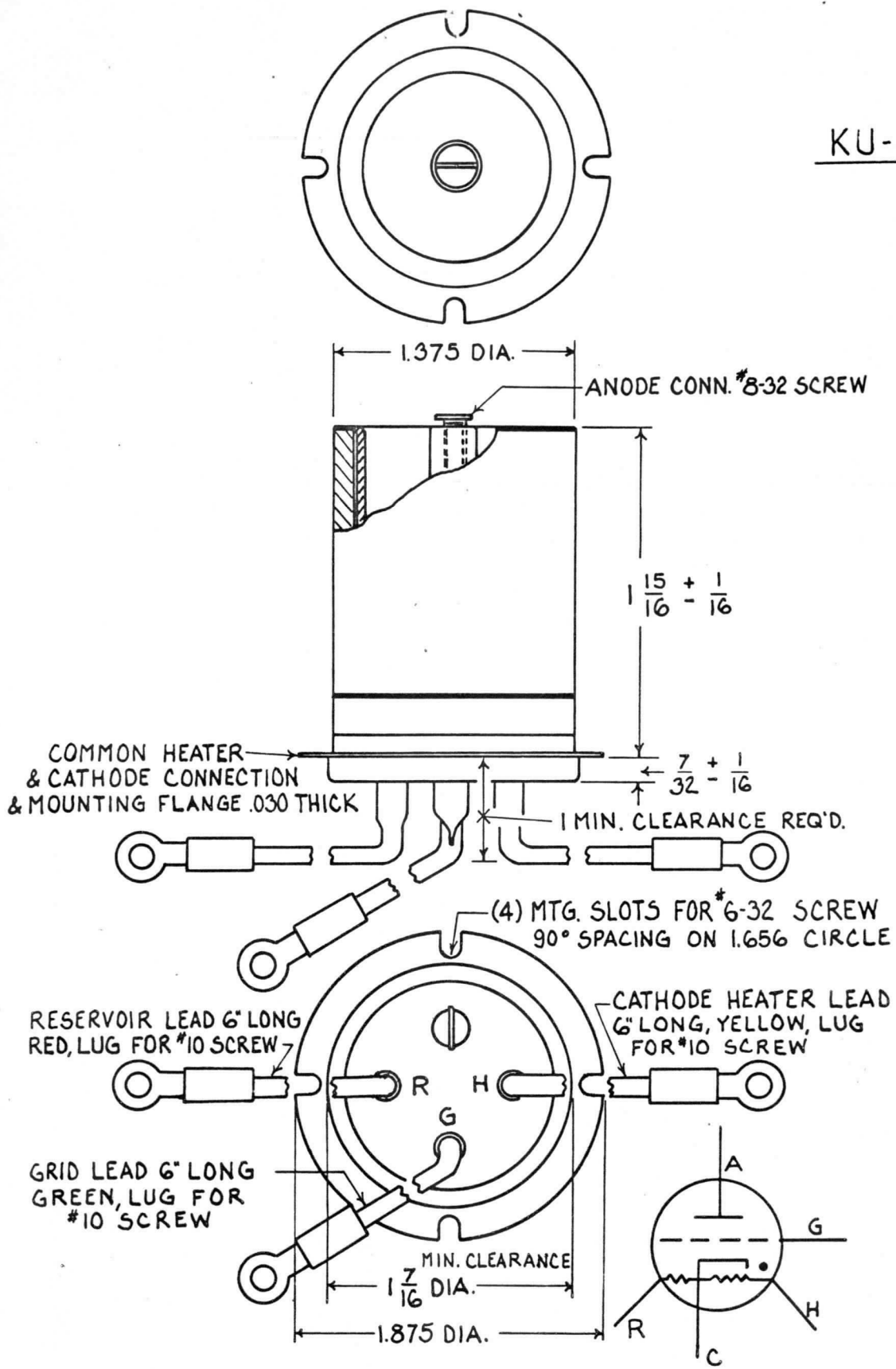



DESCRIPTION:

THE 1257 IS A UNIPOTENTIAL CATHODE, THREE ELEMENT HYDROGEN FILLED THYRATRON DESIGNED FOR A NETWORK DISCHARGE SERVICE. IN SUCH SERVICE, IT IS SUITABLE FOR PRODUCING PULSE OUTPUTS OF 33 MEGAWATTS AT AN AVERAGE POWER LEVEL OF MORE THAN 40 KW.

THE SPECIAL FEATURES OF THE 1257 INCLUDE AN INTERNAL HYDROGEN-RESERVOIR CAPABLE OF PRODUCING A WIDE RANGE OF HYDROGEN PRESSURE AND MAINTAINING THIS PRESSURE AT THE DESIRED VALUE THROUGHOUT ITS USEFUL LIFE.

<u>ELECTRICAL DATA, GENERAL:</u>	<u>Nom.</u>	<u>MIN.</u>	<u>MAX.</u>	
HEATER VOLTAGE	6.3	6.0	6.6	VOLTS A.C.
HEATER CURRENT (AT 6.3 VOLTS)		20.0	40.0	AMPERES
HEATER (NOTE 1)				
RESERVOIR VOLTAGE (NOTE 2)		3.5	6.0	VOLTS
RESERVOIR CURRENT AT 4.5 VOLTS		3.0	8.0	AMPERES
MINIMUM HEATING TIME				15 MINUTES

MECHANICAL DATA, GENERAL:

MOUNTING POSITION	VERTICAL ONLY,	BASE DOWN
BASE		PER OUTLINE
ANODE CAP		PER OUTLINE
COOLING (NOTE 3)		
NET WEIGHT	10	POUNDS
DIMENSIONS		SEE OUTLINE

KUTHE
1257
HYDROGEN
THYRATRON

- 2 -

RATINGS:

MAX. PEAK ANODE VOLTAGE, FORWARD	33.0	KILOVOLTS
MAX. PEAK ANODE VOLTAGE, INVERSE (NOTE 4)	33.0	KILOVOLTS
MIN. ANODE SUPPLY VOLTAGE	3.5	KILOVOLTS D.C.
MAX. PEAK ANODE CURRENT	2000	AMPERES
MAX. AVERAGE ANODE CURRENT	2.6	AMPERES
MAX. RMS ANODE CURRENT (NOTE 5)	60	AMPERES A.C.
MAX. EPY X IB X PRR	20 X 10 ⁹	
MAX. ANODE CURRENT RATE OF RISE	10,000	AMPERES/ μ SECOND
PEAK TRIGGER VOLTAGE (NOTE 6)		
MAX. PEAK INVERSE TRIGGER VOLTAGE	650	VOLTS
MAX. ANODE DEAD TIME (NOTE 7)	1.0	MICROSECOND
MAX. ANODE DELAY TIME DRIFT	0.10	MICROSECOND
MAX. TIME JITTER (NOTE 8)	0.01	MICROSECOND (INITIAL)
	0.02	μ SECOND (END OF LIFE)
AMBIENT TEMPERATURE	-55 ^o TO +75 ^o	CENT.

TYPICAL OPERATION AS PULSE MODULATOR, DC RESONANT CHARGING:

PEAK NETWORK VOLTAGE	33.0	20.0	KILOVOLTS
PULSE REPETITION RATE	310	1500	PULSES/SEC.
PULSE LENGTH	2.5	1.3	MICROSECOND
PULSE FORMING NETWORK IMPEDANCE	8.6	15.6	OHMS
TRIGGER VOLTAGE	1500	1500	VOLTS
PEAK POWER OUTPUT (RESISTIVE LOAD 92% ZN)	31	6.2	MEGAWATT
PEAK ANODE CURRENT	2000	667	AMPERES
AVERAGE ANODE CURRENT	1.55	1.3	AMPERES D.C.

NOTE 1:

CATHODE CONNECTED TO CENTER OF CATHODE HEATER.

NOTE 2:

RESERVOIR VOLTAGE IS MARKED ON THE BASE OF EACH VC-1257. THIS IS THE CORRECT VOLTAGE FOR ONE TYPICAL OPERATING CONDITION BUT IS NOT THE OPTIMUM VALUE FOR ALL TYPES OF OPERATION. THIS VALUE MAY BE USED INITIALLY IN NEW APPLICATIONS AND THE OPTIMUM VALUE MAY THEN BE OBTAINED BY EXPLORING THE RANGE OF VOLTAGE ON EITHER SIDE OF THAT MARKED ON THE TUBE. EXCESS RESERVOIR VOLTAGE WILL RESULT IN A FAILURE OF THE THYRATRON TO DEIONIZE BETWEEN PULSES (CONTINUOUS CONDUCTION). INSUFFICIENT RESERVOIR VOLTAGE WILL RESULT IN EXCESS ANODE DISSIPATION AS INDICATED BY VISIBLE HEATING OF THE ANODE. THE OPTIMUM RESERVOIR VOLTAGE IS THE MIDPOINT BETWEEN THESE TWO EXTREMES. IN CERTAIN APPLICATIONS IT MAY BE NECESSARY TO PROVIDE A REGULATED SOURCE TO ASSURE OPERATION WITHIN THE PERMISSIBLE RANGE OF RESERVOIR VOLTAGES. CONSULT MANUFACTURER FOR STARTING PROGRAM IF NECESSARY.

NOTE 3:

COOLING OF THE ANODE LEAD IS PERMISSIBLE, BUT THERE SHALL BE NO AIR BLAST DIRECTLY ON THE BULB.

NOTE 4:

DURING THE FIRST 25 MICROSECONDS AFTER CONDUCTION, THE PEAK INVERSE ANODE VOLTAGE SHALL NOT EXCEED 5 KV.

NOTE 5:

THE ROOT MEAN SQUARE ANODE CURRENT SHALL BE COMPUTED AS THE SQUARE ROOT OF THE PRODUCT OF PEAK CURRENT AND THE AVERAGE CURRENT.

NOTE 6:

THE PULSE PRODUCED BY THE DRIVER CIRCUIT SHALL HAVE THE FOLLOWING CHARACTERISTICS WHEN VIEWED AT THE 1257 SOCKET WITH THE TUBE REMOVED.

A. AMPLITUDE	1300-2500 VOLTS
B. DURATION	2 MICROSECONDS (AT 70% POINTS)
C. TIME OF RISE	0.35 MICROSECONDS (MIN.)
D. IMPEDANCE	10-25 OHMS

THE LIMITS OF ANODE TIME DELAY AND ANODE TIME JITTER ARE BASED ON THE MINIMUM TRIGGER. USING THE HIGHEST PERMISSIBLE TRIGGER VOLTAGE AND LOWEST TRIGGER SOURCE IMPEDANCE MATERIALLY REDUCES THESE VALUES BELOW THE LIMITS SPECIFIED.

NOTE 7:

THE TIME OF ANODE DELAY IS MEASURED BETWEEN THE 26 PERCENT POINT ON THE RISING PORTION OF THE UNLOADED GRID VOLTAGE PULSE AND THE POINT AT WHICH ANODE CONDUCTION FIRST EVIDENCES ITSELF ON THE LOADED GRID PULSE.

NOTE 8:

TIME JITTER IS MEASURED AT THE 50 PERCENT POINT ON THE ANODE CURRENT PULSE.

ADDITIONAL INFORMATION FOR SPECIFIC APPLICATIONS CAN BE OBTAINED FROM THE

ELECTRON TUBE APPLICATIONS SECTION
ITT COMPONENTS DIVISION - P.O. BOX 412
CLIFTON, NEW JERSEY



CATHODE CONNECTED INTERNALLY TO BASE

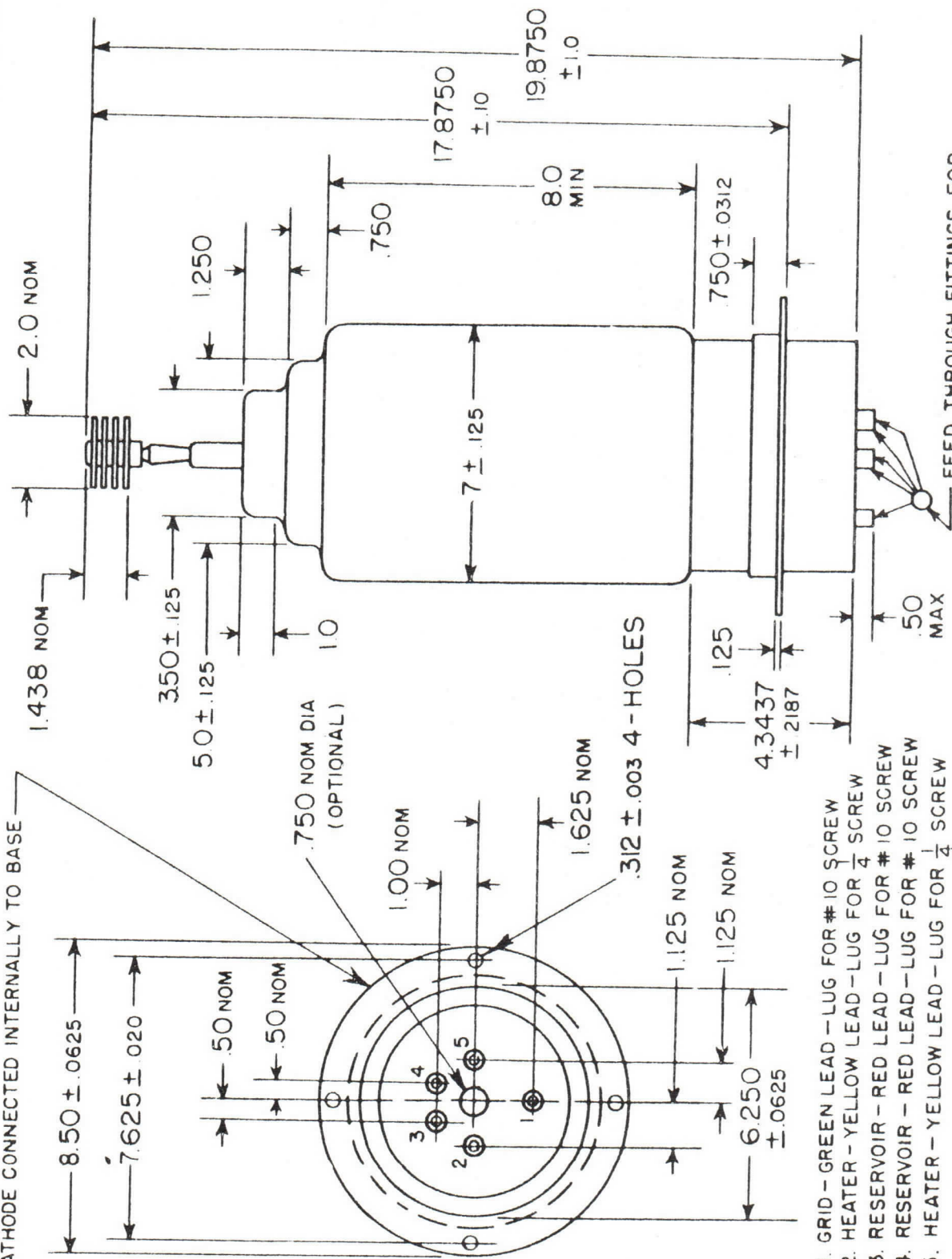

FEED THROUGH FITTINGS FOR
 $8.0 \pm .750$ FLEXIBLE LEADS ATTACHED

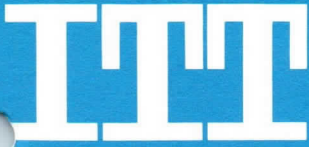

DESCRIPTION:

THE 5948 IS A UNIPOTENTIAL CATHODE, THREE ELEMENT HYDROGEN FILLED THYRATRON DESIGNED FOR NETWORK DISCHARGE SERVICE. IN SUCH SERVICE, IT IS SUITABLE FOR PRODUCING PULSE OUTPUTS OF MORE THAN 12 MEGAWATTS AT AN AVERAGE POWER LEVEL OF MORE THAN 12 KW.

THE SPECIAL FEATURES OF THE 5948 INCLUDE AN INTERNAL HYDROGEN-RESERVOIR CAPABLE OF PRODUCING A WIDE RANGE OF HYDROGEN PRESSURE AND MAINTAINING THIS PRESSURE AT THE DESIRED VALUE THROUGHOUT ITS USEFUL LIFE. FURTHER FEATURES ARE THE HIGH PEAK VOLTAGE AND CURRENT RATINGS.

ELECTRICAL DATA, GENERAL:

	<u>NOM.</u>	<u>MIN.</u>	<u>MAX.</u>	
HEATER VOLTAGE	6.3	5.9	6.7	VOLTS A.C.
HEATER CURRENT (AT 6.3 VOLTS) HEATER (NOTE 1)		25.0	33.0	AMPERES
RESERVOIR VOLTAGE (NOTE 2)		2.5	5.5	VOLTS
RESERVOIR CURRENT AT 4.5 VOLTS		3.0	6.0	AMPERES
MINIMUM HEATING TIME				15 MINUTES

MECHANICAL DATA, GENERAL:

MOUNTING POSITION	VERTICAL ONLY, BASE DOWN
BASE	PER OUTLINE
ANODE CAP	PER OUTLINE
COOLING (NOTE 3)	
NET WEIGHT	4-1/2 POUNDS
DIMENSIONS	PER OUTLINE

RATINGS:

MAX. PEAK ANODE VOLTAGE, FORWARD	25	KILOVOLTS
MAX. PEAK ANODE VOLTAGE, INVERSE (NOTE 4)	25	KILOVOLTS
MIN. ANODE SUPPLY VOLTAGE	5.0	KILOVOLTS D.C.
MAX. PEAK ANODE CURRENT	1000	AMPERES
MAX. AVERAGE ANODE CURRENT	1.0	AMPERES
MAX. RMS ANODE CURRENT (NOTE 5)	31.8	AMPERES A.C.
MAX. EPY X IB X PRR	9.0 X 10 ⁹	
MAX. ANODE CURRENT RATE OF RISE	5000	AMPERES/USECOND
PEAK TRIGGER VOLTAGE (NOTE 6)		
MAX. PEAK INVERSE TRIGGER VOLTAGE	650	VOLTS
MAX. ANODE DELAY TIME (NOTE 7)	1.0	MICROSECOND
MAX. ANODE DELAY TIME DRIFT	0.25	MICROSECOND
MAX. TIME JITTER (NOTE 8)	0.01	MICROSECOND (INITIAL)
	0.02	USECOND (END OF LIFE)
AMBIENT TEMPERATURE	-55° to +75°	CENT.

TYPICAL OPERATION AS PULSE MODULATOR, DC RESONANT CHARGING:

PEAK NETWORK VOLTAGE	25.0	15.0	KILOVOLTS
PULSE REPETITION RATE	360	1500	PULSES/SECOND
PULSE LENGTH	2.5	1.25	MICROSECOND
PULSE FORMING NETWORK IMPEDANCE	13	15.6	OHMS
TRIGGER VOLTAGE	800	800	VOLTS
PEAK POWER OUTPUT (RESISTIVE LOAD 92% ZN)	11.7	3.6	MEGAWATT
PEAK ANODE CURRENT	1000	500	AMPERES
AVERAGE ANODE CURRENT	0.90	0.94	AMPERES D.C.

NOTE 1:

CATHODE CONNECTED TO CENTER OF CATHODE HEATER.

NOTE 2:

RESERVOIR VOLTAGE IS MARKED ON THE BASE OF EACH 5948.

THIS IS THE CORRECT VOLTAGE FOR ONE TYPICAL OPERATING CONDITION BUT IS NOT THE OPTIMUM VALUE FOR ALL TYPES OF OPERATION. THIS VALUE MAY BE USED INITIALLY IN NEW APPLICATIONS AND THE OPTIMUM VALUE MAY THEN BE OBTAINED BY EXPLORING THE RANGE OF VOLTAGE ON EITHER SIDE OF THAT MARKED ON THE TUBE. EXCESS-RESERVOIR VOLTAGE WILL RESULT IN A FAILURE OF THIS THYRATRON TO DEIONIZE BETWEEN PULSES (CONTINUOUS CONDUCTION). INSUFFICIENT RESERVOIR VOLTAGE WILL RESULT IN EXCESS ANODE DISSIPATION AS INDICATED BY VISIBLE HEATING OF THE ANODE. THE OPTIMUM RESERVOIR VOLTAGE IS THE MIDPOINT BETWEEN THESE TWO EXTREMES. IN CERTAIN APPLICATIONS IT MAY BE NECESSARY TO PROVIDE A REGULATED SOURCE TO ASSURE OPERATION WITHIN THE PERMISSIBLE RANGE OF RESERVOIR VOLTAGES.

NOTE 3:

COOLING OF THE ANODE LEAD IS PERMISSIBLE, BUT THERE SHALL BE NO AIR BLAST DIRECTLY ON THE BULB.

NOTE 4:

DURING THE FIRST 25 MICROSECONDS AFTER CONDUCTION, THE PEAK INVERSE ANODE VOLTAGE SHALL NOT EXCEED 5 KV.

NOTE 5:

THE ROOT MEAN SQUARE ANODE CURRENT SHALL BE COMPUTED AS THE SQUARE ROOT OF THE PRODUCT OF PEAK CURRENT AND THE AVERAGE CURRENT.

NOTE 6:

THE PULSE PRODUCED BY THE DRIVER CIRCUIT SHALL HAVE THE FOLLOWING CHARACTERISTICS WHEN VIEWED AT THE 5948 SOCKET WITH THE TUBE REMOVED:

- A. AMPLITUDE 700-1000 VOLTS
- B. DURATION 2 MICROSECONDS (AT 70% POINTS)
- C. RATE OF RISE 1000 VOLTS/MICROSECOND (MIN.)
- D. IMPEDANCE 50-200 OHMS

THE LIMITS OF ANODE TIME DELAY AND ANODE TIME JITTER ARE BASED ON THE MINIMUM TRIGGER. USING THE HIGHEST PERMISSIBLE TRIGGER VOLTAGE AND LOWEST TRIGGER SOURCE IMPEDANCE WILL MATERIALLY REDUCE THESE VALUES BELOW THE LIMITS SPECIFIED.

NOTE 7:

THE TIME OF ANODE DELAY IS MEASURED BETWEEN THE 26 PERCENT POINT ON THE RISING PORTION OF THE UNLOADED GRID VOLTAGE PULSE AND THE POINT AT WHICH ANODE CONDUCTION FIRST EVIDENCES ITSELF ON THE LOADED GRID PULSE.

NOTE 8:

TIME JITTER IS MEASURED AT THE 50 PERCENT POINT ON THE ANODE CURRENT PULSE.

ADDITIONAL INFORMATION FOR SPECIFIC APPLICATIONS CAN BE OBTAINED FROM THE:

ELECTRON TUBE APPLICATIONS SECTION
ITT COMPONENTS DIVISION
Post Office Box 412
CLIFTON, NEW JERSEY



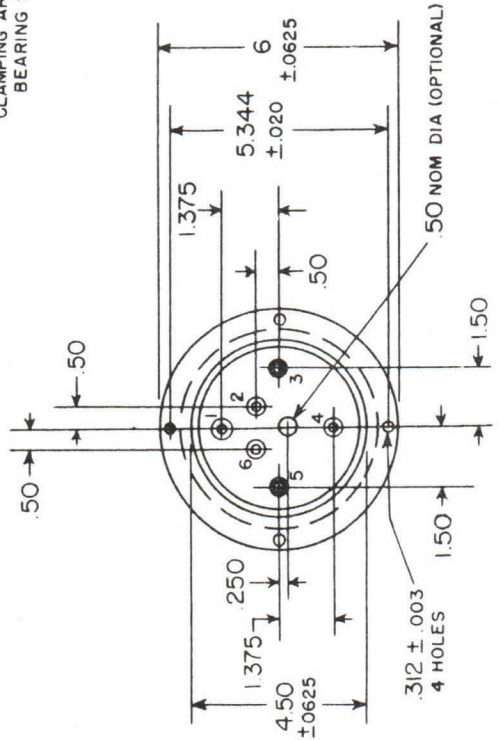
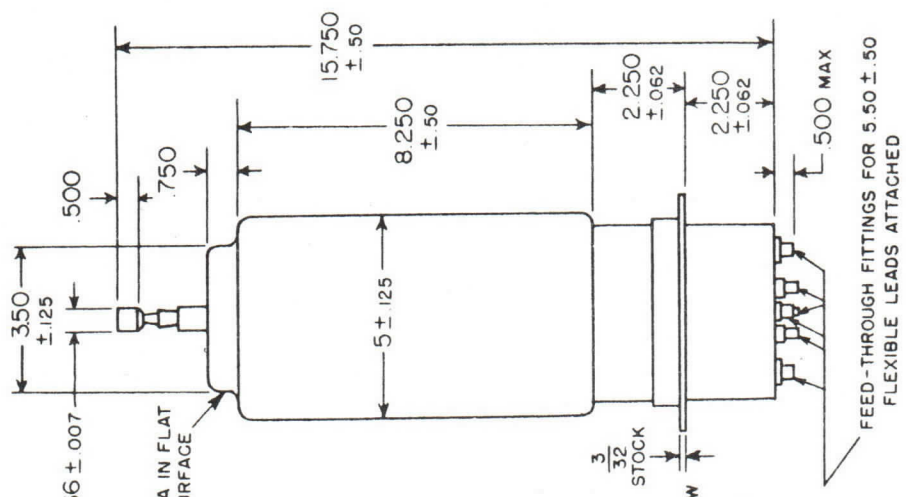

1. CATHODE & CATHODE HEATER CENTER TAP - BLACK LEAD - LUG FOR $\frac{1}{4}$ SCREW
 2. RESERVOIR - RED LEAD WITH YELLOW BAND * LUG FOR #10 SCREW
 3. CATHODE HEATER - YELLOW LEAD WITH BLACK BAND * LUG FOR $\frac{1}{4}$ SCREW
 4. GRID - GREEN LEAD - LUG FOR #10 SCREW
 5. HEATER - YELLOW LEAD - LUG FOR $\frac{1}{4}$ SCREW
 6. RESERVOIR - RED LEAD WITH YELLOW BAND - LUG FOR #10 SCREW
- * INTERNALLY CONNECTED IN BASE

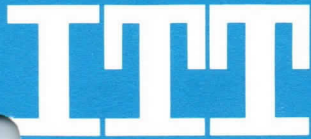

DESCRIPTION:

THE 5948A IS A UNIPOTENTIAL CATHODE, THREE ELEMENT HYDROGEN FILLED THYRATRON DESIGNED FOR NETWORK DISCHARGE SERVICE. IN SUCH SERVICE, IT IS SUITABLE FOR PRODUCING PULSE OUTPUTS OF MORE THAN 12 MEGAWATTS AT AN AVERAGE POWER LEVEL OF MORE THAN 12 KW.

THE SPECIAL FEATURES OF THE 5948A INCLUDE AN INTERNAL HYDROGEN-RESERVOIR CAPABLE OF PRODUCING A WIDE RANGE OF HYDROGEN PRESSURE AND MAINTAINING THIS PRESSURE AT THE DESIRED VALUE THROUGHOUT ITS USEFUL LIFE. FURTHER FEATURES ARE THE HIGH PEAK VOLTAGE AND CURRENT RATINGS.

<u>ELECTRICAL DATA, GENERAL:</u>	<u>NOM.</u>	<u>MIN.</u>	<u>MAX.</u>	
HEATER VOLTAGE	6.3	5.9	6.7	VOLTS A.C.
HEATER CURRENT (AT 6.3 VOLTS)		25.0	33.0	AMPERES
HEATER (NOTE 1)				
RESERVOIR VOLTAGE (NOTE 2)		2.5	5.5	VOLTS
RESERVOIR CURRENT AT 4.5 VOLTS		3.0	6.0	AMPERES
MINIMUM HEATING TIME				3 MINUTES

MECHANICAL DATA, GENERAL:

MOUNTING POSITION	VERTICAL ONLY,	BASE DOWN
BASE		PER OUTLINE
ANODE CAP		PER OUTLINE
COOLING (NOTE 3)		
NET WEIGHT	4-1/2	POUNDS
DIMENSIONS		SEE OUTLINE

KUTHE
5948A
HYDROGEN
THYRATRON

- 2 -

RATINGS:

MAX. PEAK ANODE VOLTAGE, FORWARD	25	KILOVOLTS
MAX. PEAK ANODE VOLTAGE, INVERSE (NOTE 4)	25	KILOVOLTS
MIN. ANODE SUPPLY VOLTAGE	5.0	KILOVOLTS D.C.
MAX. PEAK ANODE CURRENT	1,000	AMPERES
MAX. AVERAGE ANODE CURRENT	1.0	AMPERES
MAX. RMS ANODE CURRENT (NOTE 5)	30.0	AMPERES A.C.
MAX. EPY X IB X PRR	9.0×10^9	
MAX. ANODE CURRENT RATE OF RISE	5,000	AMPERES/ μ SECOND
PEAK TRIGGER VOLTAGE (NOTE 6)		
MAX. PEAK INVERSE TRIGGER VOLTAGE	650	VOLTS
MAX. ANODE DELAY TIME (NOTE 7)	1.0	MICROSECOND
MAX. ANODE DELAY TIME DRIFT	0.25	MICROSECOND
MAX. TIME JITTER (NOTE 8)	0.01	MICROSECOND (INITIAL)
	0.01	μ SECOND (END OF LIFE)
AMBIENT TEMPERATURE	-55° TO +75°	CENT.

TYPICAL OPERATION AS PULSE MODULATOR, DC RESONANT CHARGING:

PEAK NETWORK VOLTAGE	25.0	15.0	KILOVOLTS
PULSE REPETITION RATE	360	1,500	PULSES/SECOND
PULSE LENGTH	2.5	1.25	MICROSECOND
PULSE FORMING NETWORK IMPEDANCE	13	15.6	OHMS
TRIGGER VOLTAGE	800	800	VOLTS
PEAK POWER OUTPUT (RESISTIVE LOAD 92% ZN)	11.7	3.6	MEGAWATT
PEAK ANODE CURRENT	1,000	500	AMPERES
AVERAGE ANODE CURRENT	0.90	0.94	AMPERES D.C.

NOTE 1:

CATHODE CONNECTED TO CENTER OF CATHODE HEATER.

NOTE 2:

RESERVOIR VOLTAGE IS MARKED ON THE BASE OF EACH 5948A.

THIS IS THE CORRECT VOLTAGE FOR ONE TYPICAL OPERATING CONDITION BUT IS NOT THE OPTIMUM VALUE FOR ALL TYPES OF OPERATION. THIS VALUE MAY BE USED INITIALLY IN NEW APPLICATIONS AND THE OPTIMUM VALUE MAY THEN BE OBTAINED BY EXPLORING THE RANGE OF VOLTAGE ON EITHER SIDE OF THAT MARKED ON THE TUBE. EXCESS-RESERVOIR VOLTAGE WILL RESULT IN A FAILURE OF THIS THYRATRON TO DEIONIZE BETWEEN PULSES (CONTINUOUS CONDUCTION). INSUFFICIENT RESERVOIR VOLTAGE WILL RESULT IN EXCESS ANODE DISSIPATION AS INDICATED BY VISIBLE HEATING OF THE ANODE. THE OPTIMUM RESERVOIR VOLTAGE IS THE MIDPOINT BETWEEN THESE TWO EXTREMES.

IN CERTAIN APPLICATIONS IT MAY BE NECESSARY TO PROVIDE A REGULATED SOURCE TO ASSURE OPERATION WITHIN THE PERMISSIBLE RANGE OF RESERVOIR VOLTAGES.

NOTE 3:

COOLING OF THE ANODE LEAD IS PERMISSIBLE, BUT THERE SHALL BE NO AIR BLAST DIRECTLY ON THE BULB.

NOTE 4:

DURING THE FIRST 25 MICROSECONDS AFTER CONDUCTION, THE PEAK INVERSE ANODE VOLTAGE SHALL NOT EXCEED 5 KV.

NOTE 5:

THE ROOT MEAN SQUARE ANODE CURRENT SHALL BE COMPUTED AS THE SQUARE ROOT OF THE PRODUCT OF PEAK CURRENT AND THE AVERAGE CURRENT.

NOTE 6:

THE PULSE PRODUCED BY THE DRIVER CIRCUIT SHALL HAVE THE FOLLOWING CHARACTERISTICS WHEN VIEWED AT THE 5948A SOCKET WITH THE TUBE REMOVED:

- | | |
|-----------------|--------------------------------|
| A. AMPLITUDE | 700-1000 VOLTS |
| B. DURATION | 2 MICROSECONDS (AT 70% POINTS) |
| C. RATE OF RISE | 1000 VOLTS/MICROSECOND (MIN.) |
| D. IMPEDANCE | 50-200 OHMS |

THE LIMITS OF ANODE TIME DELAY AND ANODE TIME JITTER ARE BASED ON THE MINIMUM TRIGGER. USING THE HIGHEST PERMISSIBLE TRIGGER VOLTAGE AND LOWEST TRIGGER SOURCE IMPEDANCE WILL MATERIALLY REDUCE THESE VALUES BELOW THE LIMITS SPECIFIED.

NOTE 7:

THE TIME OF ANODE DELAY IS MEASURED BETWEEN THE 26 PERCENT POINT ON THE RISING PORTION OF THE UNLOADED GRID VOLTAGE PULSE AND THE POINT AT WHICH ANODE CONDUCTION FIRST EVIDENCES ITSELF ON THE LOADED GRID PULSE.

NOTE 8:

TIME JITTER IS MEASURED AT THE 50 PERCENT POINT ON THE ANODE CURRENT PULSE.

ADDITIONAL INFORMATION FOR SPECIFIC APPLICATIONS CAN BE OBTAINED FROM THE

ELECTRON TUBE APPLICATIONS SECTION
ITT COMPONENTS DIVISION - P.O. Box 412
CLIFTON, NEW JERSEY

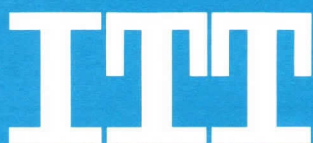

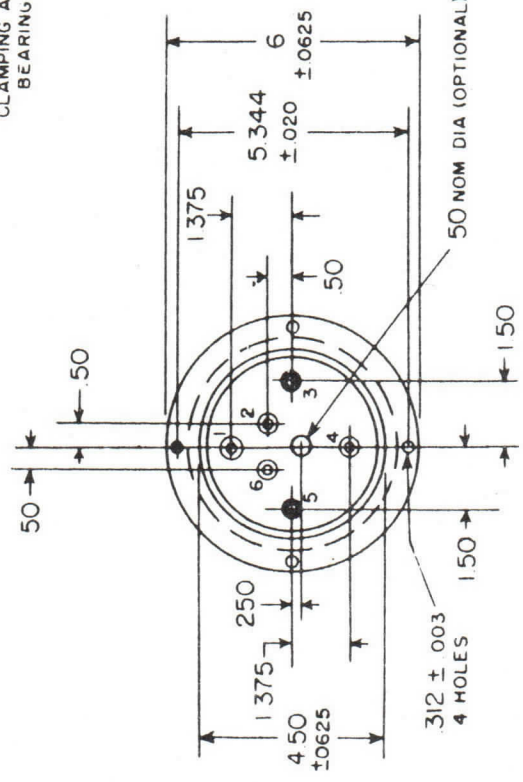
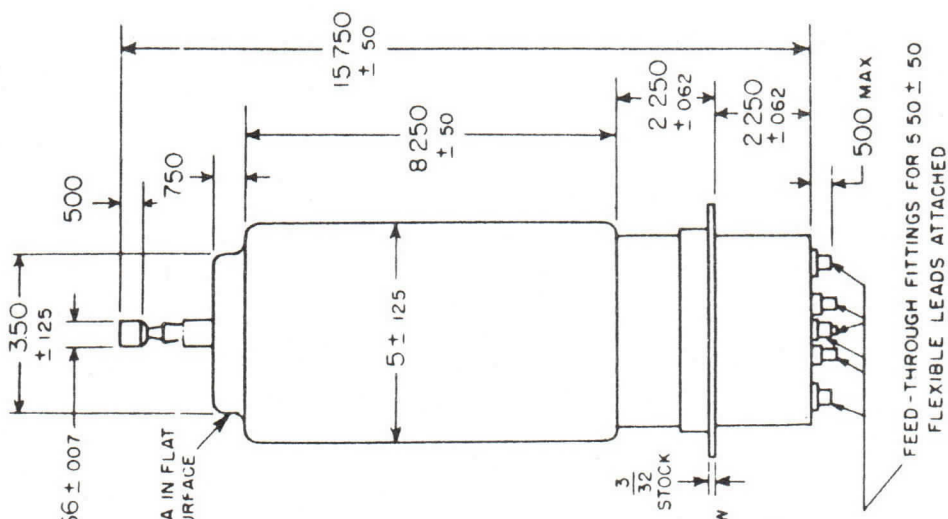

1. CATHODE HEATER CENTER TAP - BLACK LEAD - LUG FOR 1/4 SCREW
 2. RESERVOIR - READ LEAD WITH YELLOW BAND * LUG FOR #10 SCREW
 3. CATHODE HEATER - YELLOW LEAD WITH BLACK BAND * LUG FOR 1/4 SCREW
 4. GRID - GREEN LEAD - LUG FOR #10 SCREW
 5. HEATER - YELLOW LEAD - LUG FOR 1/4 SCREW
 6. RESERVOIR - RED LEAD WITH YELLOW BAND - LUG FOR #10 SCREW
- * INTERNALLY CONNECTED IN BASE

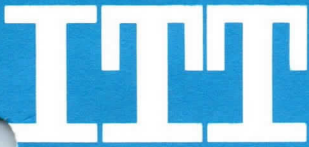

DESCRIPTION:

THE 5949 IS A UNIPOTENTIAL CATHODE, THREE ELEMENT HYDROGEN FILLED THYRATRON DESIGNED FOR NETWORK DISCHARGE SERVICE. IN SUCH SERVICE, IT IS SUITABLE FOR PRODUCING PULSE OUTPUTS OF MORE THAN 6 MEGAWATTS AT AN AVERAGE POWER LEVEL OF MORE THAN 6 KW.

THE SPECIAL FEATURES OF THE 5949 INCLUDE AN INTERNAL HYDROGEN RESERVOIR CAPABLE OF PRODUCING A WIDE RANGE OF HYDROGEN PRESSURE AND MAINTAINING THIS PRESSURE AT THE DESIRED VALUE THROUGHOUT ITS USEFUL LIFE.

ELECTRICAL DATA, GENERAL:

	<u>NOM.</u>	<u>MIN.</u>	<u>MAX.</u>	
HEATER VOLTAGE	6.3	6.0	6.6	VOLTS A.C.
HEATER CURRENT (AT 6.3 VOLTS)		15.0	22.0	AMPERES
HEATER (NOTE 1)				
RESERVOIR VOLTAGE (NOTE 2)		3.0	5.5	VOLTS
RESERVOIR CURRENT AT 4.5 VOLTS		2.0	5.0	AMPERES
MINIMUM HEATING TIME				15 MINUTES

MECHANICAL DATA, GENERAL:

MOUNTING POSITION		ANY
BASE		PER OUTLINE
ANODE CAP		PER OUTLINE
COOLING (NOTE 3)		
NET WEIGHT	1-1/2	POUNDS
DIMENSIONS		SEE OUTLINE

RATINGS:

MAX. PEAK ANODE VOLTAGE, FORWARD	25.0	KILOVOLTS
MAX. PEAK ANODE VOLTAGE, INVERSE (NOTE 4)	25.0	KILOVOLTS
MIN. ANODE SUPPLY VOLTAGE	5.0	KILOVOLTS D.C.
MAX. PEAK ANODE CURRENT	500	AMPERES
MAX. AVERAGE ANODE CURRENT	500	MILLIAMPERES
MAX. RMS ANODE CURRENT (NOTE 5)	15.8	AMPERES A.C.
MAX. EPY X IB X PRR	6.25 x 10 ⁹	
MAX. ANODE CURRENT RATE OF RISE	2,500	AMPERES/ USECOND
PEAK TRIGGER VOLTAGE (NOTE 6)		
MAX. ANODE DELAY TIME (NOTE 7)	1.0	MICROSECOND
MAX. ANODE DELAY TIME DRIFT	0.25	MICROSECOND
MAX. TIME JITTER (NOTE 8)	0.01	MICROSECOND (INITIAL)
	0.02	USECOND (END OF LIFE)
AMBIENT TEMPERATURE	-55° TO 75°	CENT.

TYPICAL OPERATION AS PULSE MODULATOR, DC RESONANT CHARGING:

PEAK NETWORK VOLTAGE	25.0	20.0	KILOVOLTS
PULSE REPETITION RATE	500	1200	PULSES/SECOND
PULSE LENGTH	2.0	1.0	MICROSECOND
PULSE FORMING NETWORK IMPEDANCE	26	52	OHMS
TRIGGER VOLTAGE	600	600	VOLTS
PEAK POWER OUTPUT (RESISTIVE LOAD 92% ZN)	5.9	1.9	MEGAWATT
PEAK ANODE CURRENT	500	200	AMPERES
AVERAGE ANODE CURRENT	0.50	0.24	AMPERES D.C.

NOTE 1:

CATHODE CONNECTED TO CENTER OF CATHODE HEATER.

NOTE 2:

THE OPTIMUM RESERVOIR VOLTAGE FOR OPERATION AT 500 PULSES/SEC. (MAX.) WITH A PEAK FORWARD VOLTAGE (EPY) OF 25 KV (MAX.) IS INSCRIBED ON THE BASE OF THE TUBE. APPLICATIONS INVOLVING OTHER OPERATING CONDITIONS WILL NECESSITATE THE REDETERMINATION OF THE OPTIMUM RESERVOIR VALUE. ANY OPTIMUM VALUE SHOULD BE HELD TO WITHIN ±5%. EXCESS RESERVOIR VOLTAGE WILL RESULT IN A FAILURE OF THIS THYRATRON TO DEIONIZE BETWEEN PULSES (CONTINUOUS CONDUCTION). INSUFFICIENT RESERVOIR VOLTAGE WILL RESULT IN EXCESS ANODE DISSIPATION AS INDICATED BY VISIBLE HEATING OF THE ANODE.

THE OPTIMUM RESERVOIR VOLTAGE IS THE MIDPOINT BETWEEN THESE TWO EXTREMES. IN CERTAIN APPLICATIONS IT MAY BE NECESSARY TO PROVIDE A REGULATED SOURCE TO ASSURE OPERATION WITHIN THE PERMISSIBLE RANGE OF RESERVOIR VOLTAGES.

NOTE 3:

COOLING OF THE ANODE LEAD IS PERMISSIBLE, BUT THERE SHALL BE NO AIR BLAST DIRECTLY ON THE BULB.

NOTE 4:

DURING THE FIRST 25 MICROSECONDS AFTER CONDUCTION, THE PEAK INVERSE ANODE VOLTAGE SHALL NOT EXCEED 5 KV.

NOTE 5:

THE ROOT MEAN SQUARE ANODE CURRENT SHALL BE COMPUTED AS THE SQUARE ROOT OF THE PRODUCT OF PEAK CURRENT AND THE AVERAGE CURRENT.

NOTE 6:

THE PULSE PRODUCED BY THE DRIVER CIRCUIT SHALL HAVE THE FOLLOWING CHARACTERISTICS WHEN VIEWED AT THE 5949 SOCKET WITH THE TUBE GRID DISCONNECTED:

A. AMPLITUDE	550-1000 VOLTS
B. DURATION,	2 MICROSECONDS (AT 70% POINTS)
C. RATE OF RISE	1800 VOLTS/MICROSECOND (MIN.)
D. IMPEDANCE	50-200 OHMS

THE LIMITS OF ANODE TIME DELAY AND ANODE TIME JITTER ARE BASED ON THE MINIMUM TRIGGER. USING THE HIGHEST PERMISSIBLE TRIGGER VOLTAGE AND LOWEST TRIGGER SOURCE IMPEDANCE MATERIALLY REDUCES THESE VALUES BELOW THE LIMITS SPECIFIED.

NOTE 7:

THE TIME OF ANODE DELAY IS MEASURED BETWEEN THE 26 PERCENT POINT ON THE RISING PORTION OF THE UNLOADED GRID VOLTAGE PULSE AND THE POINT AT WHICH ANODE CONDUCTION FIRST EVIDENCES ITSELF ON THE LOADED GRID PULSE.

NOTE 8:

TIME JITTER IS MEASURED AT THE 50 PERCENT POINT ON THE ANODE CURRENT PULSE.

ADDITIONAL INFORMATION FOR SPECIFIC APPLICATIONS CAN BE OBTAINED FROM THE

ELECTRON TUBE APPLICATIONS SECTION
ITT COMPONENTS DIVISION - P.O. Box 412
CLIFTON, NEW JERSEY



1. CAPSULE-HEATER
2. CATHODE
3. GRID
4. CAPSULE
5. HEATER

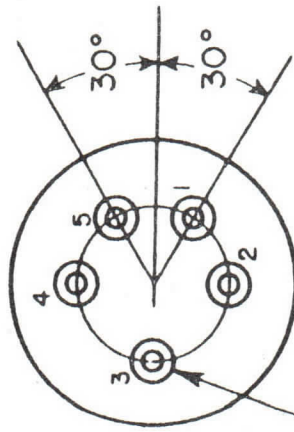

5 PIN A5-19 SHELL
 .187 ± .003 DIA. PIN
 1.250 DIA. PIN CIRCLE

NOTE: CONSULT MFG ON CLAMPING

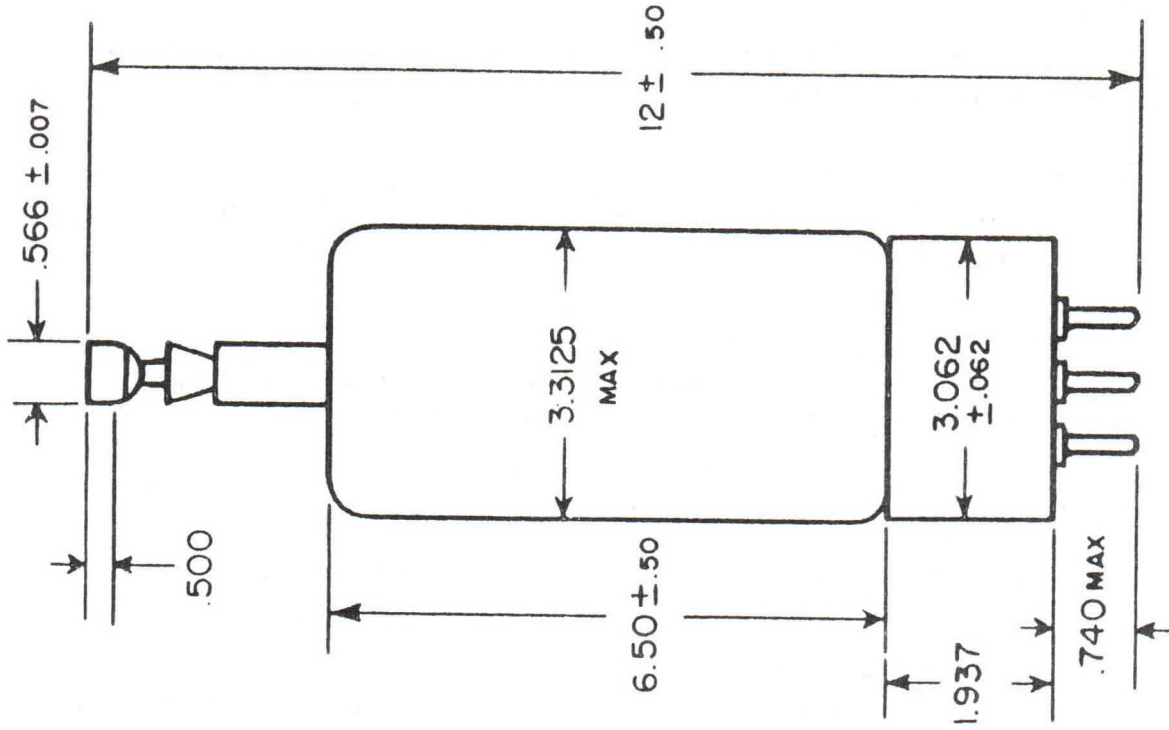

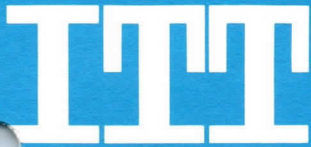

DESCRIPTION:

THE 5956 IS A UNIPOTENTIAL CATHODE, THREE ELEMENT HYDROGEN FILLED THYRATRON DESIGNED FOR NETWORK DISCHARGE SERVICE. IN SUCH SERVICE IT IS SUITABLE FOR PRODUCING PULSE OUTPUTS OF MORE THAN 350 KW AT AN AVERAGE POWER LEVEL OF MORE THAN 400 WATTS. IT IS ESPECIALLY SUITABLE FOR COMPACT, AIRBORNE RADAR SYSTEMS.

THE SPECIAL FEATURES OF THE 5956 INCLUDE THE HIGH PEAK VOLTAGE AND CURRENT RATING, THE VERY COMPACT SIZE, AND A HYDROGEN RESERVOIR CONNECTED INTERNALLY ACROSS THE FILAMENT, CAPABLE OF MAINTAINING THE HYDROGEN PRESSURE THROUGHOUT THE USEFUL LIFE OF THE TUBE.

ELECTRICAL DATA, GENERAL:

	<u>NOM.</u>	<u>MIN.</u>	<u>MAX.</u>	
HEATER VOLTAGE	6.3	5.9	6.7	VOLTS A.C.
HEATER CURRENT (AT 6.3 VOLTS)		5.5	6.7	AMPERES
MINIMUM HEATING TIME				3 MINUTES

MECHANICAL DATA, GENERAL:

MOUNTING POSITION				ANY
BASE			A4-102	
ANODE CAP				PER OUTLINE
COOLING (NOTE 1)				
NET WEIGHT			4	OUNCES
DIMENSIONS				SEE OUTLINE

TYPICAL OPERATION AS PULSE MODULATOR, DC RESONANT CHARGING:

PEAK NETWORK VOLTAGE	8.0	KILOVOLTS
PULSE REPETITION RATE	4,500	PULSES/SECOND
PULSE LENGTH	0.25	MICROSECOND
PULSE FORMING NETWORK IMPEDANCE	50.2	OHMS
TRIGGER VOLTAGE	200	VOLTS
PEAK POWER OUTPUT (RESISTIVE LOAD 92% ZN)	311	KILOWATTS
PEAK ANODE CURRENT	83	AMPERES
AVERAGE ANODE CURRENT	0.094	AMPERES D.C.

RATINGS:

MAX. PEAK ANODE VOLTAGE, FORWARD	8.0	KILOVOLTS
MAX. PEAK ANODE VOLTAGE, INVERSE (NOTE 2)	8.0	KILOVOLTS
MIN. ANODE SUPPLY VOLTAGE	2.5	KILOVOLTS D.C.
MAX. PEAK ANODE CURRENT	83	AMPERES
MAX. AVERAGE ANODE CURRENT	100	MILLIAMPERES
MAX. RMS ANODE CURRENT (NOTE 3)	2.9	AMPERES A.C.
MAX. EPY X IB X PRR	2.5×10^9	
MAX. ANODE CURRENT RATE OF RISE	1,200	AMPERE/ μ SECOND
PEAK TRIGGER VOLTAGE (NOTE 4)		
MAX. PEAK INVERSE TRIGGER VOLTAGE	200	VOLTS

	<u>INITIAL LIMIT</u>	<u>END OF LIMIT LIMIT</u>	
MAX. ANODE DELAY TIME (NOTE 5)	0.5	0.6	μ SECOND
MAX. ANODE DELAY TIME DRIFT	0.1	0.1	μ SECOND
MAX. TIME JITTER (NOTE 6)	0.01	0.02	μ SECOND
AMBIENT TEMPERATURE		-50° to 90°	CENT.
SHOCK RATING		24°	NAVY (FLYWEIGHT) SHOCK MACHINE
ALTITUDE		50,000	FEET AT 5.5 KV PEAK AND 57 AMPERES PEAK

NOTE 1:

COOLING PERMITTED. HOWEVER, THERE SHALL BE NO AIRBLAST DIRECTLY ON THE BULB.

NOTE 2:

THE PEAK INVERSE VOLTAGE SHOULD NOT EXCEED 2.5 KV DURING THE FIRST 25 MICROSECONDS AFTER CONDUCTION.

NOTE 3:

THE ROOT MEAN SQUARE ANODE CURRENT SHALL BE COMPUTED AS THE SQUARE ROOT OF THE PRODUCT OF THE PEAK CURRENT AND THE AVERAGE CURRENT.

NOTE 4:

THE VOLTAGE BETWEEN GRID AND CATHODE TERMINALS OF THE SOCKET WITH THE TUBE REMOVED SHOULD HAVE THE FOLLOWING CHARACTERISTICS.

A. VOLTAGE	175-250 VOLTS
B. DURATION	2 MICROSECONDS (AT 70% POINTS)
C. SOURCE IMPEDANCE	1500 OHMS (MAX.)
D. RATE OF RISE	200 VOLTS/MICROSECOND (MIN.)

THE LIMITS OF ANODE TIME DELAY AND ANODE TIME JITTER ARE BASED ON THE MINIMUM TRIGGER. USING THE HIGHEST PERMISSIBLE TRIGGER VOLTAGE AND LOWEST TRIGGER SOURCE IMPEDANCE MATERIALLY REDUCES THESE VALUES BELOW THE LIMITS SPECIFIED.

NOTE 5:

THE TIME OF ANODE DELAY IS MEASURED BETWEEN THE 26 PERCENT POINT ON THE RISING PORTION OF THE UNLOADED GRID VOLTAGE PULSE AND THE POINT AT WHICH EVIDENCE OF ANODE CONDUCTION FIRST APPEARS ON THE LOADED GRID PULSE.

NOTE 6:

TIME JITTER IS MEASURED AT THE 50 PERCENT POINT ON THE ANODE CURRENT PULSE.

ADDITIONAL INFORMATION FOR SPECIFIC APPLICATIONS CAN BE OBTAINED FROM THE

ELECTRON TUBE APPLICATIONS SECTION
ITT COMPONENTS DIVISION
POST OFFICE BOX 412
CLIFTON, NEW JERSEY



TOP LEAD .08 ± .003
TUNGSTEN WIRE

.188 MIN

1.390 o.d.

.625

2.375
NOM

4.50
± .250

.969

.594

.750

.375

.750

CLAMPING AREA HERE.
CLAMP INSULATED
FROM GROUND

1.50
± .06

1.70
MAX

- 1. HEATER
- 2. CATHODE
- 3. GRID
- 4. HEATER CATHODE
TOP LEAD - ANODE

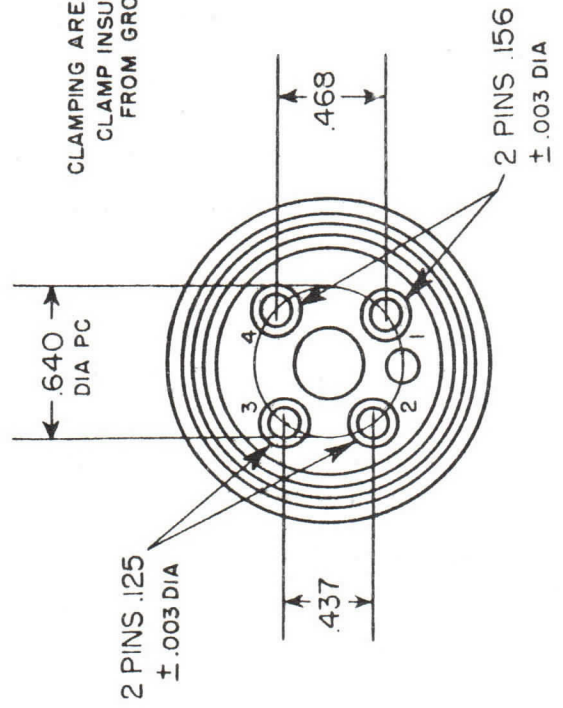

A 4 - 120 Base

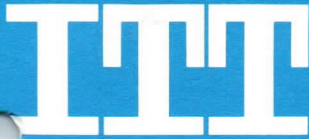

DESCRIPTION:

THE 5957 IS A UNIPOTENTIAL CATHODE, THREE ELEMENT HYDROGEN FILLED THYRATRON DESIGNED FOR NETWORK DISCHARGE SERVICE. IN SUCH SERVICE, IT IS SUITABLE FOR PRODUCING PULSE OUTPUTS OF MORE THAN 350 KW AT AN AVERAGE POWER LEVEL OF MORE THAN 400 WATTS. ITS SIZE MAKES IT ESPECIALLY SUITABLE FOR COMPACT, AIRBORNE RADAR SYSTEMS.

THE SPECIAL FEATURES OF THE E-37B INCLUDE THE HIGH PEAK VOLTAGE AND CURRENT RATINGS, ITS VERY COMPACT SIZE AND AN INTERNAL HYDROGEN RESERVOIR CAPABLE OF MAINTAINING THE HYDROGEN PRESSURE THROUGHOUT THE USEFUL LIFE OF THE TUBE.

ELECTRICAL DATA, GENERAL:

	<u>NOM.</u>	<u>MIN.</u>	<u>MAX.</u>	
HEATER VOLTAGE	6.3	5.7	6.9	VOLTS A.C.
HEATER CURRENT ($E_h=6.3$ volts)		5.5	6.7	AMPERES
MINIMUM HEATING TIME				3 MINUTES

MECHANICAL DATA, GENERAL:

MOUNTING POSITION	ANY
BASE	A4-103
ANODE CAP	SMALL METAL, C1-1
COOLING (NOTE 1)	
NET WEIGHT	3-1/2 OUNCES
DIMENSIONS	SEE OUTLINE

RATINGS:

MAX. PEAK ANODE VOLTAGE, FORWARD (NOTE 2)	8.0	KILOVOLTS
MAX. PEAK ANODE VOLTAGE, INVERSE (NOTE 3)	8.0	KILOVOLTS
MIN. ANODE SUPPLY VOLTAGE	2.5	KILVOLTS D.C.
MAX. PEAK ANODE CURRENT	83	AMPERES
MAX. AVERAGE ANODE CURRENT	100	MILLIAMPERES
MAX. RMS ANODE CURRENT (NOTE 4)	2.9	AMPERES A.C.
MAX. EPY X IB X PRR	2.5×10^9	
MAX. ANODE CURRENT RATE OF RISE	1,200	AMPERES/USECOND
PEAK TRIGGER VOLTAGE (NOTE 5)		
MAX. PEAK INVERSE TRIGGER VOLTAGE	200	VOLTS
MAX. ANODE DELAY TIME (NOTE 6)	0.50	MICROSECOND
MAX. ANODE DELAY TIME DRIFT	0.10	MICROSECOND
MAX. TIME JITTER (NOTE 7)	0.01	MICROSECOND
	0.02	(INITIAL) μSECOND (END OF LIFE)
AMBIENT TEMPERATURE	-50° TO 490°	CENT.
SHOCK RATING	24°	NAVY (FLYWEIGHT) SHOCK MACHINE

TYPICAL OPERATION AS PULSE MODULATOR, DC RESONANT CHARGING:

PEAK NETWORK VOLTAGE	8.0	KILOVOLTS
PULSE REPETITION RATE	4,500	PULSES/SECOND
PULSE LENGTH	0.25	MICROSECOND
PULSE FORMING NETWORK IMPEDANCE	50.2	OHMS
TRIGGER VOLTAGE	200	VOLTS
PEAK POWER OUTPUT (RESISTIVE LOAD 92% ZN)	311	KILOWATTS
PEAK ANODE CURRENT	83	AMPERES
AVERAGE ANODE CURRENT	0.094	AMPERES D.C.

NOTE 1:

COOLING PERMITTED. HOWEVER, THERE SHALL BE NO AIR BLAST DIRECTLY ON THE BULB.

NOTE 2:

FOR INSTANTANEOUS STARTING APPLICATION, WHERE THE PLATE VOLTAGE IS APPLIED INSTANTANEOUSLY, THE MAXIMUM PERMISSIBLE EPY IS 7,000 VOLTS.

NOTE 3:

THE PEAK INVERSE VOLTAGE SHOULD NOT EXCEED 2.5 KV DURING THE FIRST 25 MICRO-SECONDS AFTER THE PULSE.

NOTE 4:

THE ROOT MEAN SQUARE ANODE CURRENT SHALL BE COMPUTED AS THE SQUARE ROOT OF THE PRODUCT OF THE PEAK CURRENT AND THE AVERAGE CURRENT.

NOTE 5:

THE DRIVER PULSE, MEASURED AT THE TUBE SOCKET WITH THE THYRATRON GRID DISCONNECTED SHOULD HAVE THE FOLLOWING CHARACTERISTICS:

A. VOLTAGE	175 VOLTS (MIN.)
B. DURATION	2 MICROSECONDS (AT 70% POINTS)
C. IMPEDANCE	1500 OHMS (MAX.)
D. TIME OF RISE	0.5 MICROSECOND (MAX.)

THE LIMITS OF ANODE TIME DELAY AND ANODE TIME JITTER ARE BASED ON THE MINIMUM TRIGGER. USING THE HIGHEST PERMISSIBLE TRIGGER VOLTAGE AND LOWEST TRIGGER SOURCE IMPEDANCE MATERIALLY REDUCES THESE VALUES BELOW THE LIMITS SPECIFIED.

NOTE 6:

THE TIME OF ANODE DELAY IS MEASURED BETWEEN THE 26 PERCENT POINT ON THE RISING PORTION OF THE UNLOADED GRID VOLTAGE PULSE AND THE POINT AT WHICH EVIDENCE OF ANODE CONDUCTION FIRST APPEARS ON THE LOADED GRID PULSE.

NOTE 7:

TIME JITTER IS MEASURED AT THE 50 PERCENT POINT ON THE ANODE CURRENT PULSE.

ADDITIONAL INFORMATION FOR SPECIFIC APPLICATIONS CAN BE OBTAINED FROM THE

ELECTRON TUBE APPLICATIONS SECTION
ITT COMPONENTS DIVISION
POST OFFICE BOX 412
CLIFTON, NEW JERSEY



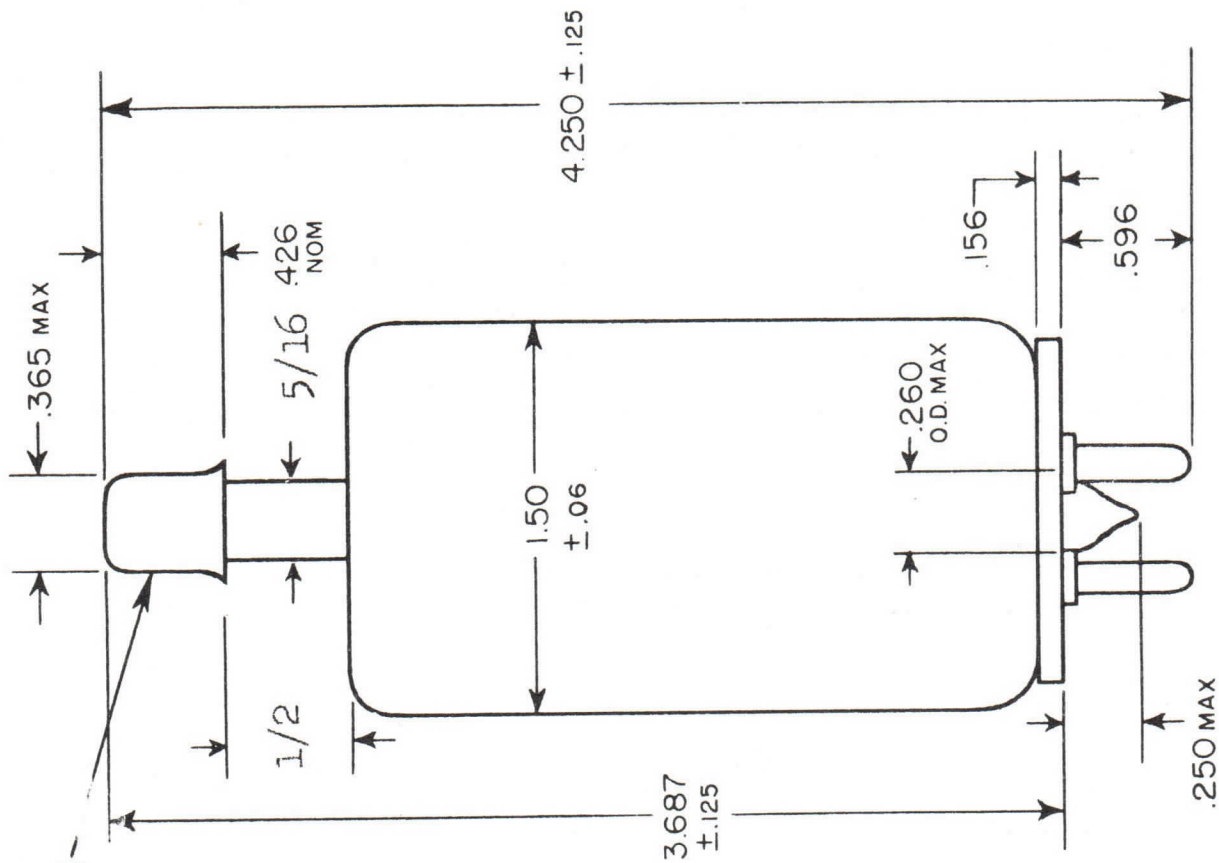

TOP CAP CI-1-

- 1. HEATER
- 2. CATHODE
- 3. GRID
- 4. HEATER & CATHODE

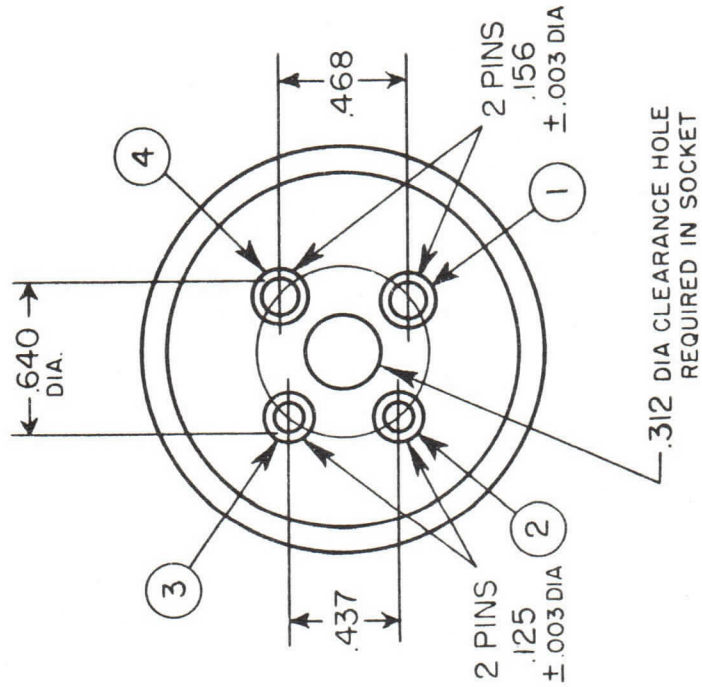

WAFER BASE
A4-103

TYPE 5957 HYDROGEN THYRATRON

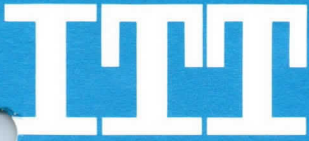

DESCRIPTION:

THE TUBES OF THIS GROUP ARE UNIPOTENTIAL CATHODE, THREE ELEMENT HYDROGEN FILLED THYRATRONS DESIGNED FOR NETWORK DISCHARGE SERVICE. IN SUCH SERVICE THEY ARE SUITABLE FOR PRODUCING PULSE OUTPUTS OF MORE THAN 120 KW AT AN AVERAGE POWER OF MORE THAN 150 WATTS. THEY ARE ESPECIALLY SUITABLE FOR COMPACT, AIRBORNE RADAR SYSTEMS.

THE SPECIAL FEATURES OF THIS GROUP OF TUBES INCLUDE THE HIGH PEAK VOLTAGE AND CURRENT RATINGS IN A VERY COMPACT SIZE.

ELECTRICAL DATA, GENERAL:

	<u>NOM.</u>	<u>MIN.</u>	<u>MAX.</u>	
HEATER VOLTAGE	6.3	5.9	6.7	VOLTS A.C.
HEATER CURRENT (AT 6.3 VOLTS)		2.0	2.5	AMPERES
MINIMUM HEATING TIME				2 MINUTES

MECHANICAL DATA, GENERAL:

MOUNTING POSITION	ANY
BASE	PER OUTLINE
ANODE CAP	PER OUTLINE
COOLING (NOTE 1)	
NET WEIGHT	4 OUNCES
DIMENSIONS	PER OUTLINE

RATINGS:

MAX. PEAK ANODE VOLTAGE, FORWARD	8.0	KILOVOLTS
MAX. PEAK ANODE VOLTAGE, INVERSE (NOTE 2)	8.0	KILOVOLTS
MIN. ANODE SUPPLY VOLTAGE	2.5	KILOVOLTS D.C.
MAX. PEAK ANODE CURRENT	35	AMPERES
MAX. AVERAGE ANODE CURRENT	45	MILLIAMPERES
MAX. RMS ANODE CURRENT (NOTE 3)	1.25	AMPERES A.C.
MAX. EPY X IB X PRR	0.75 X 10 ⁹	
MAX. ANODE CURRENT RATE OF RISE	1200	AMPERES/USECOND
PEAK TRIGGER VOLTAGE (NOTE 4)		
MAX. PEAK INVERSE TRIGGER VOLTAGE	200	VOLTS
MAX. ANODE DELAY TIME (NOTE 5)	0.6	MICROSECOND
MAX. ANODE DELAY TIME DRIFT	0.15	MICROSECOND
MAX. TIME JITTER (NOTE 6)	0.03	MICROSECOND (INITIAL)
	0.04	U/SECOND (END OF LIFE)
AMBIENT TEMPERATURE	-50° to +90°	CENT.

TYPICAL OPERATION AS PULSE MODULATOR, DC RESONANT CHARGING:

PEAK NETWORK VOLTAGE	8.0	KILOVOLTS
PULSE REPETITION RATE	2800	PULSES/SECOND
PULSE LENGTH	.25	MICROSECOND
PULSE FORMING NETWORK IMPEDANCE	119	OHMS
TRIGGER VOLTAGE	175	VOLTS
PEAK POWER OUTPUT (RESISTIVE LOAD 92% ZN)	130	KILOWATTS
PEAK ANODE CURRENT	35	AMPERES
AVERAGE ANODE CURRENT	.025	AMPERES D.C.

NOTE 1:

COOLING IS PERMITTED. HOWEVER, THERE SHALL BE NO AIR BLAST DIRECTLY ON THE BULB.

NOTE 2:

IN PULSED OPERATION, THE PEAK INVERSE VOLTAGE, EXCLUSIVE OF A SPIKE OF 0.05 MICROSECOND MAXIMUM DURATION, SHALL NOT EXCEED 2.5 KV DURING THE FIRST 25 MICROSECONDS AFTER THE PULSE.

NOTE 3:

THE ROOT MEAN SQUARE ANODE CURRENT SHALL BE COMPUTED AS THE SQUARE ROOT OF THE PRODUCT OF THE PEAK CURRENT AND THE AVERAGE CURRENT.

NOTE 4:

THE VOLTAGE BETWEEN GRID AND CATHODE TERMINALS OF THE SOCKET WITH THE TUBE REMOVED SHOULD HAVE THE FOLLOWING CHARACTERISTICS:

A. VOLTAGE	175-250 VOLTS
B. DURATION	2 MICROSECONDS (AT 70% POINTS)
C. SOURCE IMPEDANCE	1500 OHMS (MAX.)
D. RATE OF RISE	200 VOLTS/MICROSECOND (MIN.)

THE LIMITS OF ANODE TIME DELAY AND ANODE TIME JITTER ARE BASED ON THE MINIMUM TRIGGER. USING THE HIGHEST PERMISSIBLE TRIGGER VOLTAGE AND LOWEST TRIGGER SOURCE IMPEDANCE MATERIALLY REDUCES THESE VALUES BELOW THE LIMITS SPECIFIED.

NOTE 5:

THE TIME OF ANODE DELAY IS MEASURED BETWEEN THE 26 PERCENT POINT ON THE RISING PORTION OF THE UNLOADED GRID VOLTAGE PULSE AND THE POINT AT WHICH EVIDENCE OF ANODE CONDUCTION FIRST APPEARS ON THE LOADED GRID PULSE.

NOTE 6:

TIME JITTER IS MEASURED AT THE 50 PERCENT POINT ON THE ANODE CURRENT PULSE.

ADDITIONAL INFORMATION FOR SPECIFIC APPLICATIONS CAN BE OBTAINED FROM THE:

ELECTRON TUBE APPLICATIONS SECTION
ITT COMPONENTS DIVISION
POST OFFICE BOX 412
CLIFTON, NEW JERSEY



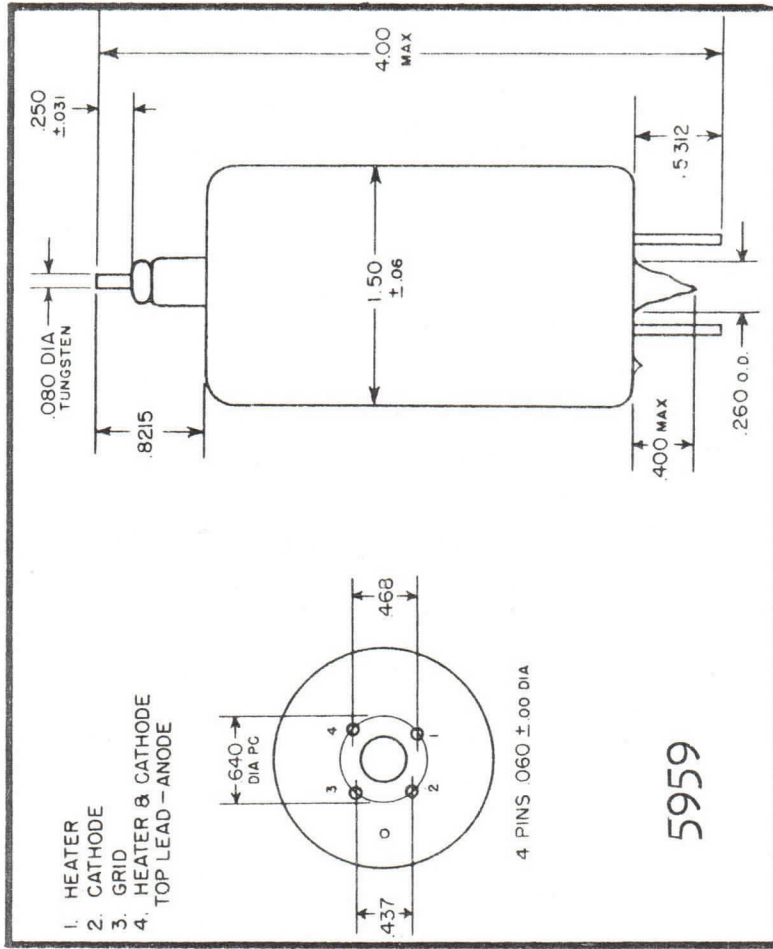
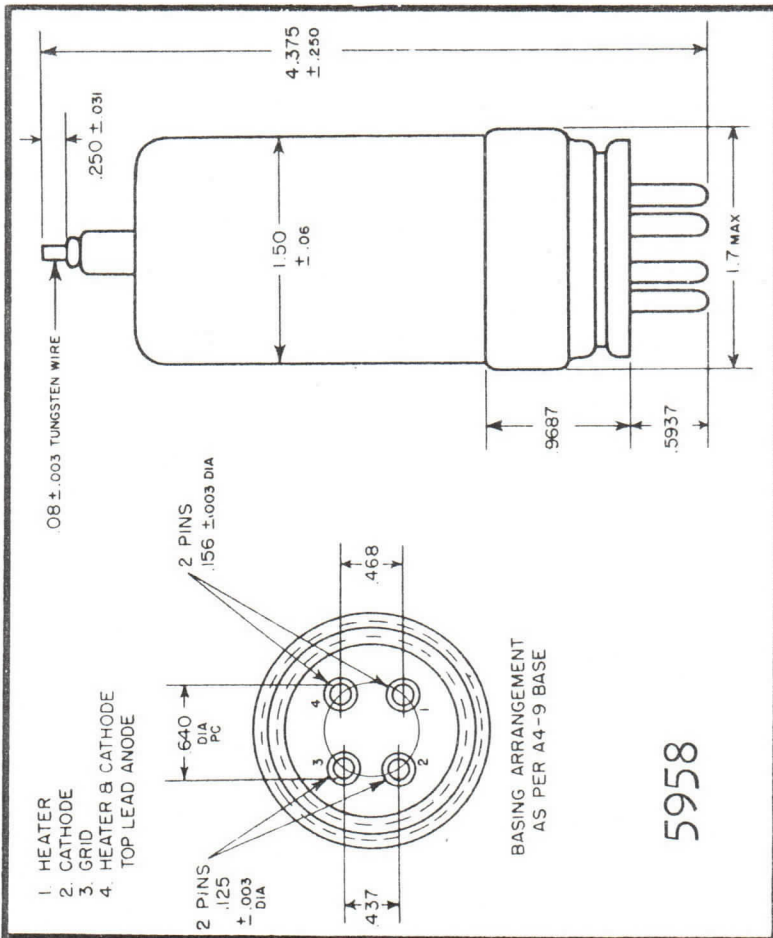

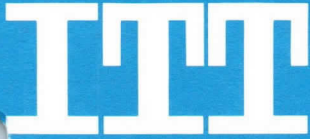

DESCRIPTION:

THE 6130 IS A UNIPOTENTIAL CATHODE, THREE ELEMENT HYDROGEN FILLED THYRATRON DESIGNED FOR NETWORK DISCHARGE SERVICE. IN SUCH SERVICE IT IS SUITABLE FOR PRODUCING PULSE OUTPUTS OF 55 KW AS AN AVERAGE POWER LEVEL OF MORE THAN 65 WATTS.

THE ELECTRICAL CHARACTERISTICS OF THE 6130 ARE IDENTICAL WITH THOSE OF THE 3C45. A SPECIAL ANODE TOP CAP INSULATOR IS INSTALLED TO PERMIT OPERATION AT HIGH ALTITUDE.

ELECTRICAL DATA, GENERAL:

	<u>NOM.</u>	<u>MIN.</u>	<u>MAX.</u>	
HEATER VOLTAGE	6.3	5.7	6.6	VOLTS A.C.
HEATER CURRENT (AT 6.3 VOLTS)		2.0	2.5	AMPERES
MINIMUM HEATING TIME				2 MINUTES

MECHANICAL DATA, GENERAL:

MOUNTING POSITION	ANY
BASE	MEDIUM, 4-PIN LOW-LOSS PHENOLIC, A49
ANODE CAP	SMALL METAL C1-1
COOLING (NOTE 1)	
NET WEIGHT	2.5 OUNCES
DIMENSIONS	SEE OUTLINE

RATINGS:

MAX. PEAK ANODE VOLTAGE, FORWARD	3.0	KILOVOLTS
MAX. PEAK ANODE VOLTAGE, INVERSE (NOTE 2)	3.0	KILOVOLTS
MIN. ANODE SUPPLY VOLTAGE	800	VOLTS D.C.
MAX. PEAK ANODE CURRENT	35	AMPERES
MAX. AVERAGE ANODE CURRENT	45	MILLIAMPERES
MAX. RMS ANODE CURRENT (NOTE 3)	1.25	AMPERES A.C.
MAX. EPY X IB X PRR	0.3×10^9	
MAX. ANODE CURRENT RATE OF RISE	750	AMPERES/USECOND
PEAK TRIGGER VOLTAGE (NOTE 4)		
MAX. PEAK INVERSE TRIGGER VOLTAGE	200	VOLTS
MAX. ANODE DELAY TIME (NOTE 5)	0.6	MICROSECOND
MAX. ANODE DELAY TIME DRIFT	0.15	MICROSECOND
MAX. TIME JITTER (NOTE 6)	0.02	MICROSECOND (INITIAL)
	0.04	USECOND (END OF LIFE)
AMBIENT TEMPERATURE	-50° TO 90°	CENT.

TYPICAL OPERATION AS PULSE MODULATOR, DC RESONANT CHARGING:

PEAK NETWORK VOLTAGE	3.0	KILOVOLTS
PULSE REPETITION RATE	2500	PULSES/SECOND
PULSE LENGTH	0.5	MICROSECOND
PULSE FORMING NETWORK IMPEDANCE	45.2	OHMS
TRIGGER VOLTAGE	200	VOLTS
PEAK POWER OUTPUT (RESISTIVE LOAD 92% ZN)	47.2	KILOWATTS
PEAK ANODE CURRENT	35	AMPERES
AVERAGE ANODE CURRENT	.044	AMPERES D.C.

NOTE 1:

COOLING IS PERMITTED. HOWEVER, THERE SHALL BE NO AIR BLAST DIRECTLY ON THE BULB.

NOTE 2:

IN PULSE OPERATION, THE PEAK INVERSE VOLTAGE, EXCLUSIVE OF A SPIKE OF 0.5 MICROSECOND MAX. DURATION, SHALL NOT EXCEED 1500 VOLTS DURING THE FIRST 25 MICROSECONDS AFTER THE PULSE.

NOTE 3:

THE ROOT MEAN SQUARE ANODE CURRENT SHALL BE COMPUTED AS THE SQUARE ROOT OF THE PRODUCT OF THE PEAK CURRENT AND THE AVERAGE CURRENT.

NOTE 4:

THE VOLTAGE BETWEEN GRID AND CATHODE TERMINALS OF THE SOCKET WITH THE TUBE REMOVED SHOULD HAVE THE FOLLOWING CHARACTERISTICS:

A. VOLTAGE	175-250 VOLTS
B. DURATION	2 MICROSECONDS (AT 70% POINTS)
C. SOURCE OF IMPEDANCE	1500 OHMS (MAX.)
D. RATE OF RISE	200 VOLTS/MICROSECOND (MIN.)

THE LIMITS OF ANODE TIME DELAY AND ANODE TIME JITTER ARE BASED ON THE MINIMUM TRIGGER. USING THE HIGHEST PERMISSIBLE TRIGGER VOLTAGE AND LOWEST TRIGGER SOURCE IMPEDANCE MATERIALLY REDUCES THESE VALUES BELOW THE LIMITS SPECIFIED.

NOTE 5:

THE TIME OF ANODE DELAY IS MEASURED BETWEEN THE 26 PERCENT POINT ON THE RISING PORTION OF THE UNLOADED GRID VOLTAGE PULSE AND THE POINT AT WHICH EVIDENCE OF ANODE CONDUCTION FIRST APPEARS ON THE LOADED GRID PULSE.

NOTE 6:

TIME JITTER IS MEASURED AT THE 50 PERCENT POINT ON THE ANODE CURRENT PULSE.

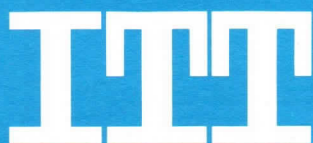

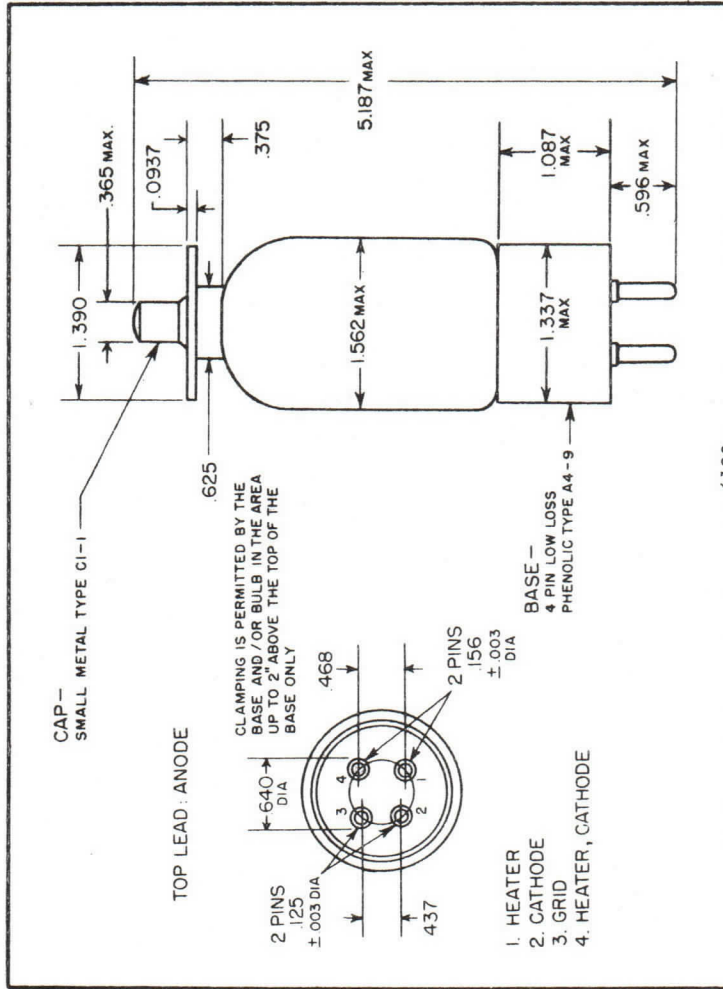

engineering TUBE DATA

Kuthe



Components Division

TYPE 6587 HYDROGEN THYRATRON

GENERAL DATA

DESCRIPTION:

The 6587 is a unipotential cathode, three element hydrogen filled thyatron designed for network discharge service. In such service it is suitable for producing pulse outputs of more than 2 megawatts at an average power level of more than 1.6 KW.

The special features of the 6587 include an internal hydrogen reservoir connected across the filament and capable of producing and maintaining the hydrogen pressure throughout the useful life of the tube. Further features are the high peak voltage and current ratings and the ruggedized construction.

Electrical Data, General	Nom.	Min.	Max.
Heater voltage.....	6.3	5.9	6.7 Volts a.c.
Heater current, $E_h=6.3$ volts.....		9.6	11.6 Amperes
Minimum heating time.....	3		Minutes

Mechanical Data, General

Mounting position.....	Any
Base.....	Super Jumbo 4-pin with Bayonet A4-18 with ceramic insert
Anode Cap.....	Medium Metal, C1-5 with corona flare
Cooling.....	Note 1
Net Weight.....	10 Ounces

Dimensions

See outline drawing

Ratings

Max. peak anode voltage, forward.....	16.0 Kilovolts
Max. peak anode voltage, inverse (Note 2).....	16.0 Kilovolts
Min. anode supply voltage.....	3.5 Kilovolts d.c.
Max. peak average anode current.....	325 Amperes
Max. average anode current.....	225 Milliampere
Max. RMS anode current (Note 3).....	6.3 Amperes a.c.
Max. epy x ib x prr.....	3.9×10^9
Max. anode current rate of rise.....	1500 Amperes/ μ second

Peak trigger voltage.....	Note 4
Max. peak inverse trigger voltage.....	200 Volts

	Initial Limit	End of Life Limit
Max. anode delay time (Note 5).....	0.6	0.6 Microsecond
Max. anode delay time drift.....	0.1	0.1 Microsecond
Max. time jitter (Note 6).....	0.005	0.01 Microsecond

Ambient temperature.....	-50° to $+90^\circ$ Cent.
Shock rating.....	24° Navy (Flyweight) Shock machine

Typical Operation as Pulse Modulator,

DC Resonant Charging

Peak network voltage.....	16.0	12.0 Kilovolts
Pulse repetition rate.....	1000	2500 Pulses/second
Pulse length.....	1.0	0.4 Microsecond
Pulse forming network impedance....	48	48 Ohms
Trigger voltage.....	200	200 Volts
Peak power output (Resistive load		
92% Zn).....	1.31	.736 Megawatt
Peak anode current.....	175	130 Amperes
Average anode current.....	0.175	0.13 Amperes d.c.

Note 1

Cooling permitted. However, there shall be no air blast directly on the bulb.

Note 2

The peak inverse anode voltage shall not exceed 5.0 kv during the first 25 microseconds after the pulse.

Note 3

The root mean square anode current shall be computed as the square root of the product of the peak current and the average current.

Note 4

The Driver pulse, measured at the tube socket with the thyatron grid disconnected, shall have the following characteristics:

- A. Voltage..... 200-300 Volts
- B. Duration..... 2 Microseconds (at 70% points)
- C. Rate of rise..... 200 Volts/microsecond (min.)
- D. Impedance..... 50-500 Ohms

The limits of anode time delay and anode time jitter are based on the minimum trigger. Using the highest permissible trigger voltage and lowest trigger source impedance materially reduces these values below the limits specified.

Note 5

The time of anode delay is measured between the 26 percent point on the rising portion of the unloaded grid voltage pulse and the point at which evidence of anode conduction first appears on the loaded grid pulse.

Note 6

Time jitter is measured at the 50 percent point on the anode current pulse.

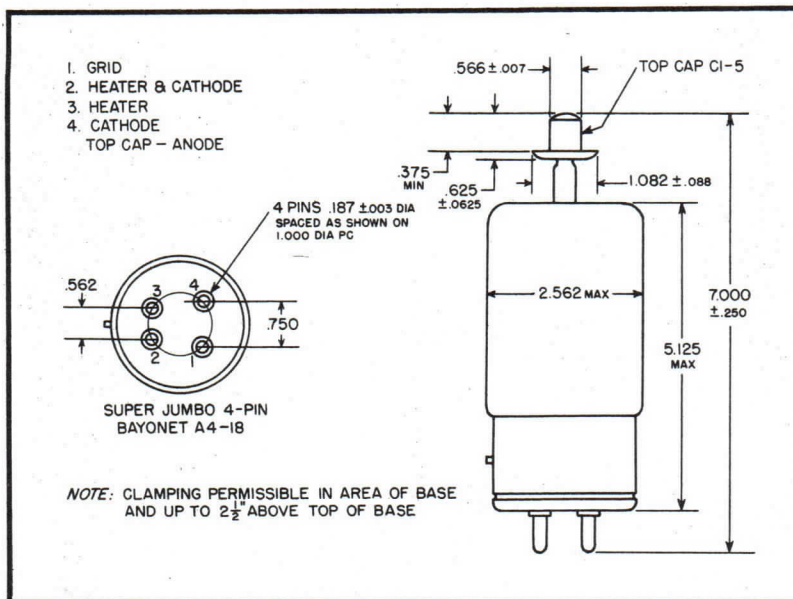

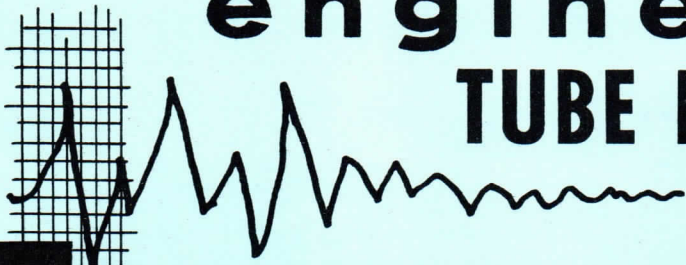

engineering TUBE DATA

Kuthe



Components Division

TYPE 6777 HYDROGEN THYRATRON

GENERAL DATA

DESCRIPTION:

The 6777 is a unipotential cathode, three element, hydrogen filled thyatron with reservoir, designed for network discharge service. In such service it is suitable for producing pulse outputs of more than 120 KW at an average power level of more than 150 watts.

The special features of the 6777 include the high peak voltage rating and the very compact size as well as the inclusion of a hydrogen reservoir for long stable tube life.

Electrical Data, General	Nom.	Min.	Max.
Heater voltage.....	6.3	5.9	6.7 Volts a.c.
Heater current. $E_H=6.3$ volts.....	2.2	2.7	Amperes
Minimum heating time.....	3 Minutes		

Mechanical Data, General	
Mounting position.....	Any
Base.....	Medium, 4-pin low-loss phenolic, A4-9
Anode cap.....	Small metal, C1-1
Cooling.....	Note 1
Net weight.....	3.5 Ounces

Dimensions

See outline drawing

Ratings

Max. peak anode voltage, forward....	8.0 Kilovolts
Max. peak anode voltage, inverse (Note 2).....	8.0 Kilovolts
Min. anode supply voltage.....	2.5 Kilovolts d.c.
Max. peak anode current.....	35 Amperes
Max. average anode current.....	45 Milliamperes
Max. RMS anode current (Note 3).....	1.25 Amperes d.c.
Max. epy x ib x prr.....	0.75×10^9
Max. anode current rate of rise.....	1200 Amperes/ μ second
Peak trigger voltage.....	Note 4
Max. peak inverse trigger voltage....	200 Volts
Max. anode delay time (Note 5).....	0.6 Microsecond
Max. anode delay time drift.....	0.15 Microsecond
Max. time jitter (Note 6).....	0.03 Microsecond (initial) 0.04 μ second (end of life)
Ambient temperature.....	-50° to $+90^\circ$ Cent.

**Typical Operation as Pulse Modulator,
DC Resonant Charging**

Peak network voltage.....	8.0 Kilovolts
Pulse repetition rate.....	2800 Pulses/second
Pulse length.....	0.25 Microsecond
Pulse forming network impedance....	119 Ohms
Trigger voltage.....	175 Volts
Peak power output (Resistive load 92% Zn).....	130 Kilowatts
Peak anode current.....	35 Amperes
Average anode current.....	.025 Amperes d.c.

Note 1

Cooling of the anode lead is permissible but there shall be no air blast directly on the bulb.

Note 2

The peak inverse voltage, exclusive of a spike of 0.05 microsecond max. duration, shall not exceed 3 KV during the first 25 microseconds after the pulse.

Note 3

The root mean square anode current shall be computed as the square root of the product of peak current and the average current.

Note 4

The voltage between grid and cathode terminals of the tube, with the grid of the tube disconnected should have the following characteristics:

- A. Voltage..... 175-250 Volts
- B. Duration..... 2.0 Microseconds (at 70% points)
- C. Time of rise..... 0.5 Microseconds (max.)
- D. Impedance..... 1500 Ohms (max.)

The limits of anode time delay and anode time jitter are based on the minimum trigger. Using the highest permissible trigger voltage and lowest trigger source impedance materially reduces these values below the limits specified.

Note 5

The time of anode delay is measured between the 26 percent point on the rising portion of the unloaded grid voltage pulse and the point at which evidence of anode conduction first appears on the loaded grid pulse.

Note 6

Time jitter is measured at the 50 percent point on the anode current pulse.

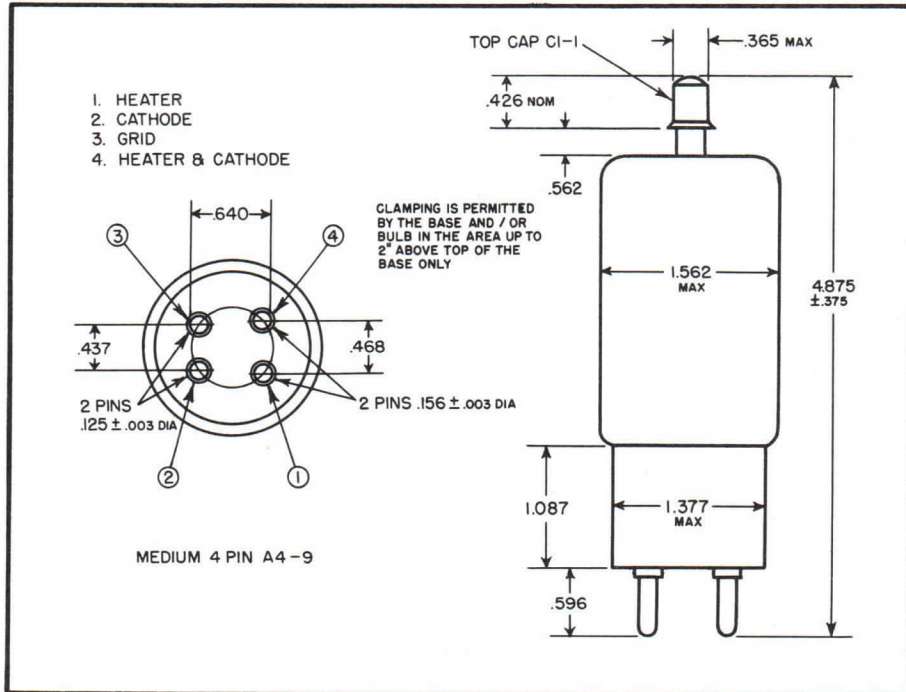

DESCRIPTION

The 7178 is a glass envelope hydrogen filled diode designed for Pulse Transformer Back swing Clipper Applications. The indirectly heated cathode, the internal hydrogen reservoir, and the rugged anode design of the 7178 combine to produce reliable service and long life.

ELECTRICAL DATA, GENERAL

	Nom.	Min.	Max.				
Heater Voltage	5.0	4.7	5.3	Volts AC	Reservoir Current (at 5.0 volts)	2.0	5.0 Amperes
Heater Current (at 5.0 volts)		14.0	24.0	Amperes	Minimum Heating Time		10 Minutes
Reservoir Voltage	5.0	4.7	5.3	Volts AC			

MECHANICAL DATA, GENERAL

Mounting Position	Any	Net Weight	1.5 Pounds
Base (Per outline)		Dimensions (Per outline)	
Cooling (Note 1)			

RATINGS (Note 2)

Max. Peak Anode Voltage, Inverse, Transient (Note 3)	30.0 KV	Max. R.M.S. Anode Current (Note 4)	15.0 Amps.
Max. Peak Anode Voltage, Inverse, Operating	16.0 KV	Min. Anode Voltage	500.0 Volts
Max. Peak Anode Current	500.0 Amps.	Ambient Temperature	-50° to +75° C
Max. Average Anode Current	0.50 Amps.		

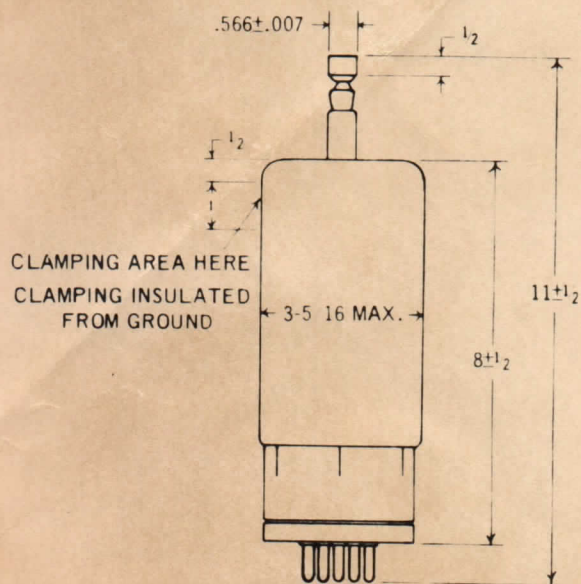

NOTE 1

Cooling of the Anode lead is permissible, but there shall be no Air blast directly on the bulb.

NOTE 2

Maximum ratings should not occur simultaneously. In special cases maximum ratings may be exceeded. Consult Applications Department.

NOTE 3

The 7173 will withstand transient, overvoltage conditions of $epx - 30 \text{ KV}$ for (1) per cent of its rated life.

NOTE 4

The Root Mean Square Anode Current shall be computed as the square root of the product of the peak and the average current.

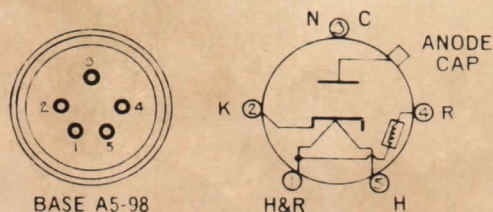

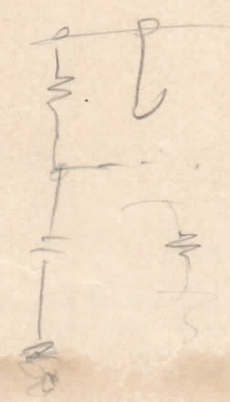
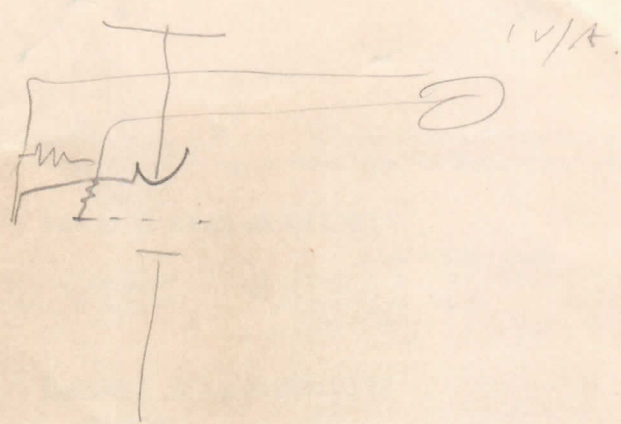

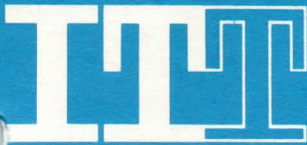

T E N T A T I V E
CERAMIC HYDROGEN THYRATRON

DESCRIPTION:

THE 7322 IS A 12.5 MEGAWATT, CERAMIC HYDROGEN THYRATRON. THE CERAMIC EXTERNAL ANODE DESIGN PERMITS OPERATION AT UNUSUALLY HIGH POWER LEVELS. THE SPECIAL FEATURES OF THE 7322 INCLUDE A HYDROGEN RESERVOIR TO MAINTAIN OPTIMUM PRESSURE AND TO INSURE LONG LIFE.

ELECTRICAL DATA, GENERAL:

	<u>Nom.</u>	<u>Min.</u>	<u>Max.</u>	
HEATER VOLTAGE	6.3	5.8	6.8	VOLTS A.C.
HEATER CURRENT (AT 6.3 VOLTS)		14.0	22.0	AMPERES
HEATER (NOTE 1)				
RESERVOIR VOLTAGE (NOTE 2)		5.8	6.8	VOLTS
RESERVOIR CURRENT AT 4.5 VOLT		4.0	6.0	AMPERES
MINIMUM HEATING TIME				5 MINUTES

MECHANICAL DATA, GENERAL:

MOUNTING POSITION	VERTICAL ONLY, BASE DOWN
BASE	PER OUTLINE
COOLING (NOTE 3)	
NET WEIGHT	3.0 POUNDS
DIMENSIONS (SEE OUTLINE DRAWING)	

RATINGS:

MAX. PEAK ANODE VOLTAGE, FORWARD	25	KILOVOLTS
MAX. PEAK ANODE VOLTAGE, INVERSE (NOTE 4)	25	KILOVOLTS
MIN. ANODE SUPPLY VOLTAGE	1.5	KILOVOLTS D.C.
MAX. PEAK ANODE CURRENT	1000	AMPERES
MAX. AVERAGE ANODE CURRENT	1.5	AMPERES
MAX. RMS ANODE CURRENT (NOTE 5)	36.0	AMPERES A.C.
MAX. EPY X IB X PRR	20.0 x 10 ⁹	
MAX. ANODE CURRENT RATE OF RISE	5000	AMPS./U SEC.
PEAK TRIGGER VOLTAGE (NOTE 6)		
MAX. PEAK INVERSE TRIGGER VOLTAGE	650	VOLTS
MAX. ANODE DELAY TIME (NOTE 7)	0.5	MICROSECOND
MAX. ANODE DELAY TIME DRIFT	0.15	MICROSECOND
MAX. TIME JITTER (NOTE 8)	0.005	MICROSECOND
AMBIENT TEMPERATURE	-55° TO / 125°	C

NOTE 1:

SEE OUTLINE DRAWING.

NOTE 2:

THE OPTIMUM RESERVOIR VOLTAGE FOR OPERATION IN ACCORDANCE WITH OPERATION (1) CONDITIONS IS INSCRIBED ON THE BASE OF THE TUBE AND MUST BE HELD TO WITHIN $\pm 7.5\%$. APPLICATIONS INVOLVING OTHER OPERATING CONDITIONS WILL NECESSITATE THE REDETERMINATION OF THE OPTIMUM RESERVOIR VOLTAGE. OPERATION (1) CONDITIONS (25 KV - 1000 A - 2.5 US - 360 PPS).

NOTE 3:

IT MAY BE DESIRABLE TO EMPLOY FORCED AIR COOLING UNDER CONDITIONS OF HIGH PB NUMBER OPERATIONS. A COOLING AIR BLAST OF 10 CFM MAY BE DIRECTED INTO THE ANODE CUP.

NOTE 4:

IN PULSED OPERATION, THE PEAK INVERSE VOLTAGE, EXCLUSIVE OF A SPIKE OF .05US MAXIMUM DURATION, SHALL NOT EXCEED 5.0 KV DURING THE FIRST 25US FOLLOWING THE ANODE PULSE.

NOTE 5:

THE ROOT MEAN SQUARE ANODE CURRENT SHALL BE COMPUTED AS THE SQUARE ROOT OF THE PRODUCT OF PEAK CURRENT AND THE AVERAGE CURRENT.

NOTE 6:

THE DRIVER PULSE, MEASURED AT TUBE SOCKET WITH THYRATRON GRID DISCONNECTED: 500 VOLTS MINIMUM, 1500 VOLTS MAXIMUM; TR = 0.35US MAXIMUM; GRID PULSE DURATION 2.0US MINIMUM. IMPEDANCE OF DRIVE CIRCUIT 50 TO 400 OHMS.

NOTE 7:

THE TIME OF ANODE DELAY IS MEASURED BETWEEN THE 26 PERCENT POINT ON THE RISING PORTION OF THE UNLOADED GRID VOLTAGE PULSE AND THE POINT AT WHICH ANODE CONDUCTION FIRST EVIDENCES ITSELF ON THE LOADED GRID PULSE.

NOTE 8:

TIME JITTER IS MEASURED AT THE 50 PERCENT POINT ON THE ANODE CURRENT PULSE.

ADDITIONAL INFORMATION FOR SPECIFIC APPLICATIONS CAN BE OBTAINED FROM THE

ELECTRON TUBE APPLICATIONS SECTION
ITT COMPONENTS DIVISION
POST OFFICE BOX 412
CLIFTON, NEW JERSEY

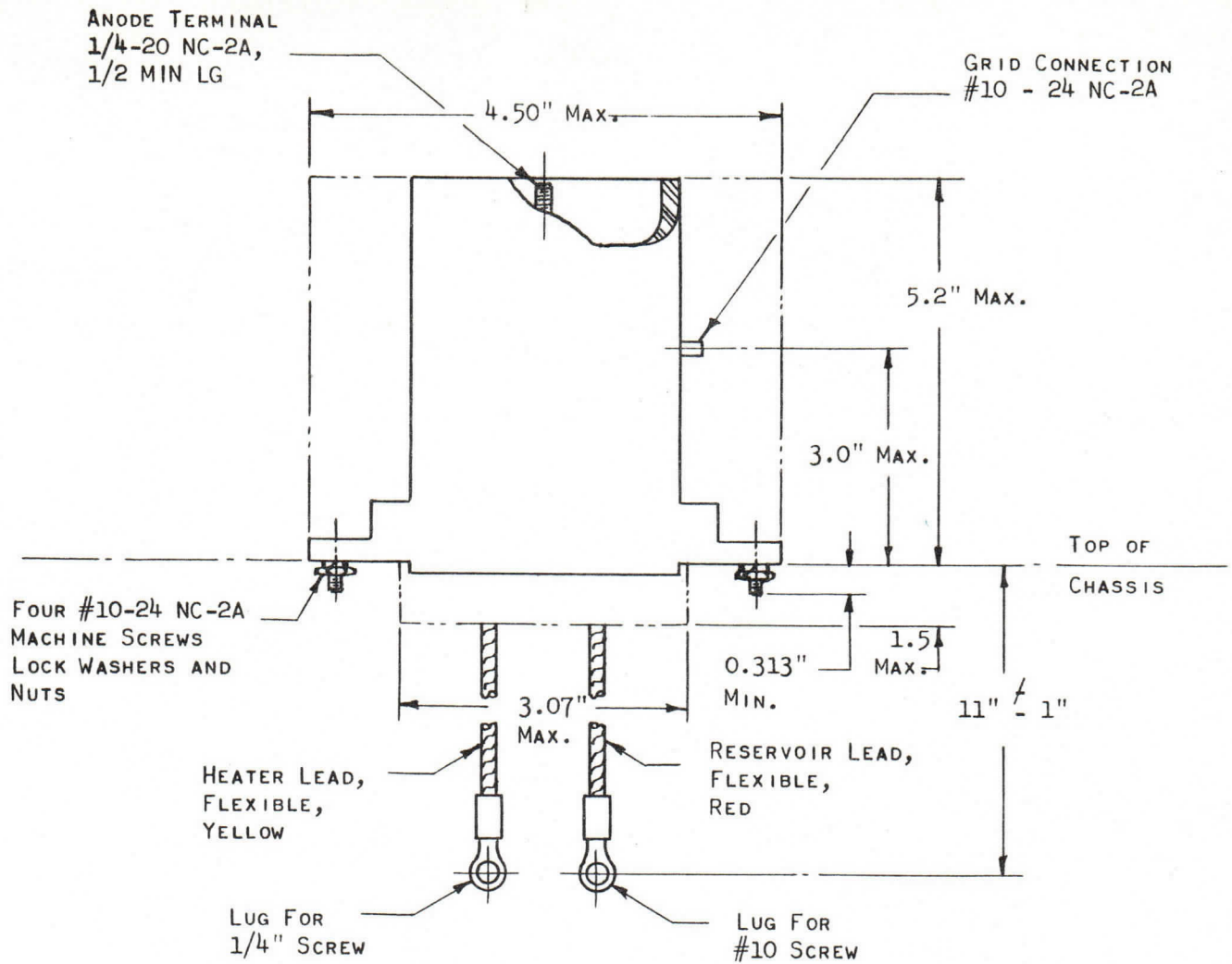

OUTLINE

7322

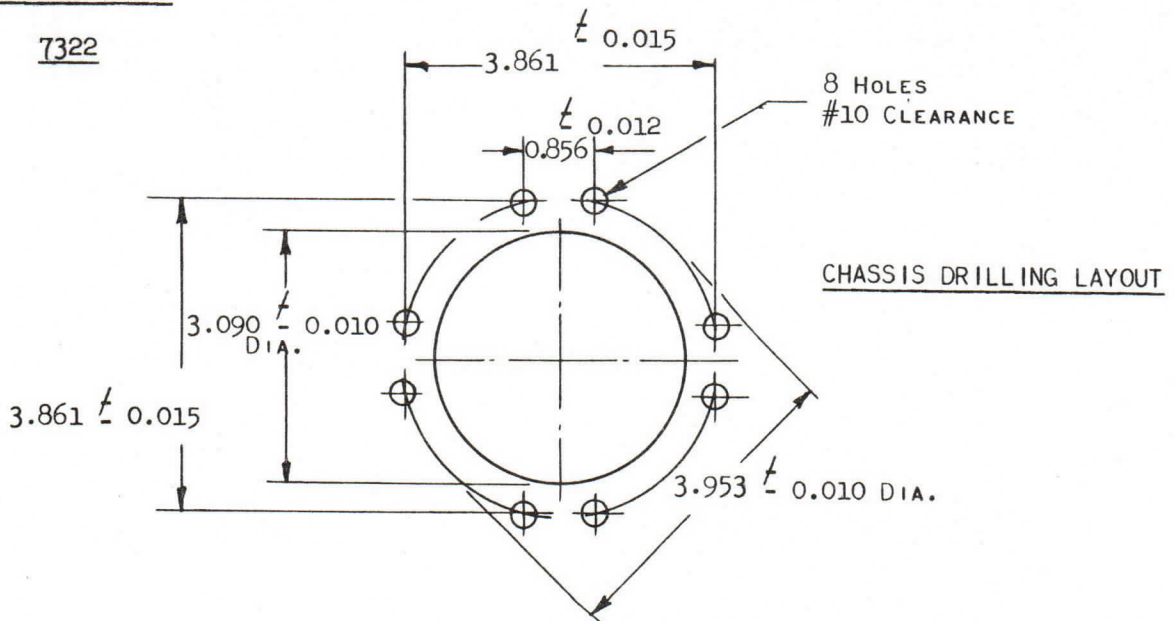

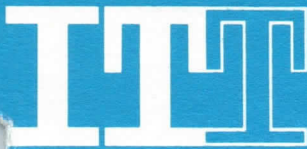

T E N T A T I V E
CERAMIC HYDROGEN THYRATRON

DESCRIPTION:

THE 7390 IS A 33 MEGAWATT, LARGE CERAMIC HYDROGEN THYRATRON. THE EXTERNAL ANODE DESIGN PERMITS OPERATION AT HIGH POWER LEVELS. THE SPECIAL FEATURES OF THE 7390 INCLUDE A HYDROGEN RESERVOIR TO MAINTAIN OPTIMUM PRESSURE AND TO INSURE LONG LIFE.

<u>ELECTRICAL DATA, GENERAL:</u>	<u>NOM.</u>	<u>MIN.</u>	<u>MAX.</u>	
HEATER VOLTAGE	6.3	5.9	6.7	VOLTS AC
HEATER CURRENT (AT 6.3 VOLTS)		22.0	35.0	AMPERES
HEATER (NOTE 1)				
RESERVOIR COLTAGE (NOTE 2)		3.5	5.5	VOLTS
RESERVOIR CURRENT AT 4.5 VOLTS		8.0	10.0	AMPERES
MINIMUM HEATING TIME				15 MINUTES

MECHANICAL DATA, GENERAL:

MOUNTING POSITION	VERTICAL ONLY, BASE DOWN
BASE (PER OUTLINE)	
COOLING (NOTE 3)	
NET WEIGHT	11.5 POUNDS
DIMENSIONS (SEE OUTLINE DRAWING)	

RATINGS:

MAX. PEAK ANODE VOLTAGE, FORWARD	33.0	KILOVOLTS
MAX. PEAK ANODE VOLTAGE, INVERSE (NOTE 4)	33.0	KILOVOLTS
MIN. ANODE SUPPLY VOLTAGE	3.5	KILOVOLTS DC
MAX. PEAK ANODE CURRENT	2000	AMPERES
MAX. AVERAGE ANODE CURRENT	4.0	AMPERES
MAX. RMS ANODE CURRENT (NOTE 5)	72	AMPERES AC
MAX. EPY x 1B x PRR	30 x 10 ⁹	
MAX. ANODE CURRENT RATE OF RISE	10000	AMPS./U SEC.
PEAK TRIGGER VOLTAGE (NOTE 6)		
MAX. PEAK INVERSE TRIGGER VOLTAGE	650	VOLTS
MAX. ANODE DELAY TIME (NOTE 7)	1.0	MICROSECOND
MAX. ANODE DELAY TIME DRIFT	0.25	MICROSECOND
MAX. TIME JITTER (NOTE 8)	0.01	MICROSECOND
AMBIENT TEMPERATURE	-55° to / 75°	C

NOTE 1:

CATHODE CONNECTED TO CENTER OF CATHODE HEATER.

NOTE 2:

RESERVOIR VOLTAGE IS MARKED ON THE BASE OF EACH 7390. THIS IS THE CORRECT VOLTAGE FOR ONE TYPICAL OPERATING CONDITION, BUT IS NOT THE OPTIMUM VALUE FOR ALL TYPES OF OPERATION. THIS VALUE MAY BE USED INITIALLY IN NEW APPLICATIONS AND THE OPTIMUM VALUE MAY THEN BE OBTAINED BY EXPLORING THE RANGE OF VOLTAGE ON EITHER SIDE OF THAT MARKED ON THE TUBE. EXCESS RESERVOIR VOLTAGE WILL RESULT IN A FAILURE OF THE THYRATRON TO DEIONIZE BETWEEN PULSES (CONTINUOUS CONDUCTION). INSUFFICIENT RESERVOIR VOLTAGE WILL RESULT IN EXCESS ANODE DISSIPATION (270°C.) AS INDICATED BY HEATING OF THE ANODE. THE OPTIMUM RESERVOIR VOLTAGE IS THE MIDPOINT BETWEEN THESE TWO EXTREMES. IN CERTAIN APPLICATIONS, IT MAY BE NECESSARY TO PROVIDE A REGULATED SOURCE TO ASSURE OPERATION WITHIN THE PERMISSIBLE RANGE OF RESERVOIR VOLTAGES.

NOTE 3:

COOLING OF THE ANODE IS PERMISSIBLE.

NOTE 4:

DURING THE FIRST 25 MICROSECONDS AFTER CONDUCTION, THE PEAK INVERSE ANODE VOLTAGE SHALL NOT EXCEED 5 KV.

NOTE 5:

THE ROOT MEAN SQUARE ANODE CURRENT SHALL BE COMPUTED AS THE SQUARE ROOT OF THE PRODUCT OF PEAK CURRENT AND THE AVERAGE CURRENT.

NOTE 6:

THE PULSE PRODUCED BY THE DRIVER CIRCUIT SHALL HAVE THE FOLLOWING CHARACTERISTICS WHEN VIEWED AT THE 7390 SOCKET WITH THE TUBE REMOVED.

- | | |
|-----------------|--------------------------------|
| A. AMPLITUDE | 1300 - 2500 VOLTS |
| B. DURATION | 2 MICROSECONDS (AT 70% POINTS) |
| C. TIME OF RISE | 0.35 MICROSECONDS (MIN.) |
| D. IMPEDANCE | 10 - 25 OHMS |

THE LIMITS OF ANODE TIME DELAY AND ANODE TIME JITTER ARE BASED ON THE MINIMUM TRIGGER. USING THE HIGHEST PERMISSIBLE TRIGGER VOLTAGE AND LOWEST TRIGGER SOURCE IMPEDANCE MATERIALLY REDUCES THESE VALUES BELOW THE LIMITS SPECIFIED.

NOTE 7:

THE TIME OF ANODE DELAY IS MEASURED BETWEEN THE 26 PERCENT POINT ON THE RISING PORTION OF THE UNLEADED GRID VOLTAGE PULSE, AND THE POINT AT WHICH ANODE CONDUCTION FIRST EVIDENCES ITSELF ON THE LOADED GRID PULSE.

NOTE 8:

TIME JITTER IS MEASURED AT THE 50% POINT ON THE ANODE CURRENT PULSE.

ADDITIONAL INFORMATION FOR SPECIFIC APPLICATIONS CAN BE OBTAINED FROM THE

ELECTRON TUBE APPLICATIONS SECTION
ITT COMPONENTS DIVISION
POST OFFICE BOX 412
CLIFTON, NEW JERSEY



O U T L I N E
7390

5/8 DIA. ANODE STUD

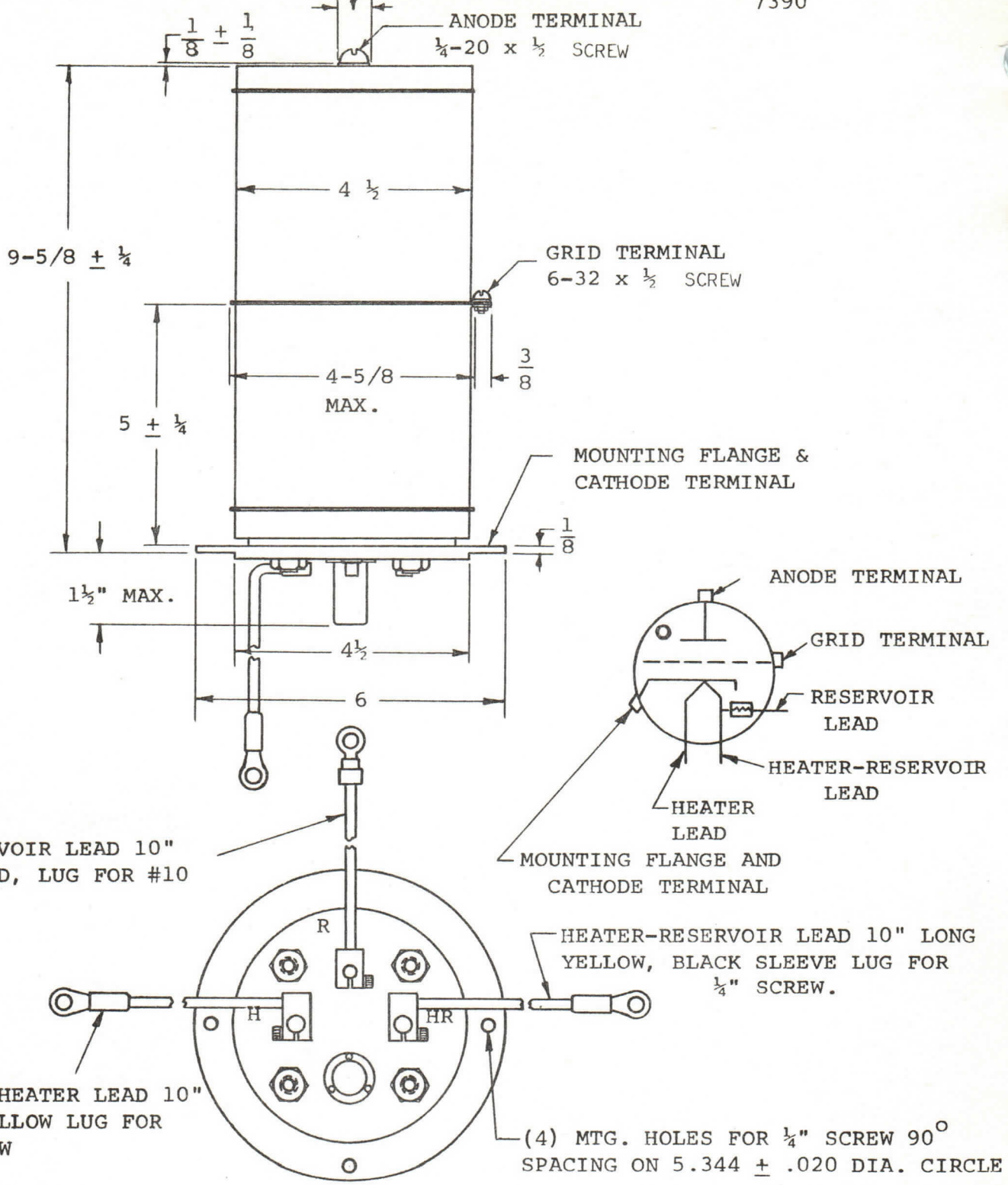

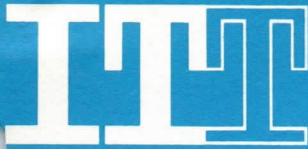

T E N T A T I V E

DESCRIPTION:

THE 7583/KU-82 IS A UNIPOTENTIAL CATHODE, THREE ELEMENT HYDROGEN FILLED THYRATRON DESIGNED FOR NETWORK DISCHARGE SERVICE. IN SUCH SERVICE IT IS SUITABLE FOR PRODUCING PULSE OUTPUTS OF MORE THAN 140 KW AT AN AVERAGE POWER OF MORE THAN 150 WATTS. IT IS ESPECIALLY SUITABLE FOR COMPACT, AIRBORNE RADAR SYSTEMS.

ELECTRICAL DATA, GENERAL:

	<u>Nom.</u>	<u>MIN.</u>	<u>MAX.</u>	
HEATER VOLTAGE	6.3	5.6	6.6	VOLTS AC
HEATER CURRENT (AT 6.3 VOLTS)		2.0	2.5	AMPERES
MINIMUM HEATING TIME				2.0 MINUTES

MECHANICAL DATA, GENERAL:

MOUNTING POSITION				ANY
BASE				PER OUTLINE
COOLING (NOTE 1)				
NET WEIGHT			0.3	POUNDS
DIMENSIONS				PER OUTLINE

RATINGS:

MAX. PEAK ANODE VOLTAGE, FORWARD			8.0	KILOVOLTS
MAX. PEAK ANODE VOLTAGE, INVERSE (NOTE 2)			8.0	KILOVOLTS
MIN. ANODE SUPPLY VOLTAGE			2.5	KILOVOLTS DC
MAX. PEAK ANODE CURRENT			35	AMPERES
MAX. AVERAGE ANODE CURRENT			45	MILLIAMPERES
MAX. RMS ANODE CURRENT (NOTE 3)			1.25	AMPERES AC
MAX. EPY X IB X PRR			1.1 x 10 ⁹	
MAX. ANODE CURRENT RATE OF RISE			1200	AMPS. / U SEC.
PEAK TRIGGER VOLTAGE (NOTE 4)				
MAX. ANODE DELAY TIME (NOTE 5)			0.60	MICROSECOND
MAX. ANODE DELAY TIME DRIFT			0.15	MICROSECOND
MAX. TIME JITTER (NOTE 6)			0.005	MICROSECOND
AMBIENT TEMPERATURE			-50 to +90	C

NOTE 1:

COOLING OF THE ANODE LEAD IS PERMISSIBLE, BUT THERE SHALL BE NO AIR BLAST DIRECTLY ON THE BULB.

NOTE 2:

IN PULSED OPERATION, THE PEAK INVERSE VOLTAGE, EXCLUSIVE OF SPIKE OF .05 US MAXIMUM DURATION, SHALL NOT EXCEED 3000 V DURING THE FIRST 25 US AFTER THE PULSE.

NOTE 3:

THE ROOT MEAN SQUARE ANODE CURRENT SHALL BE COMPUTED AS THE SQUARE ROOT OF THE PRODUCT OF THE PEAK CURRENT AND THE AVERAGE CURRENT.

NOTE 4:

DRIVER PULSE, MEASURED AT TUBE SOCKET WITH THYRATRON GRID DISCONNECTED; EGY = 175 V (MIN), TIME OF RISE = 0.5 US (MAX), GRID PULSE DURATION = 2 US (MIN). IMPEDANCE OF DRIVE CIRCUIT = 1500 OHMS (MAX).

NOTE 5:

THE TIME OF ANODE DELAY IS MEASURED BETWEEN THE 26 PERCENT POINT ON THE RISING PORTION OF THE UNLOADED GRID VOLTAGE PULSE AND THE POINT AT WHICH EVIDENCE OF ANODE CONDUCTION FIRST APPEARS ON THE LOADED GRID PULSE.

NOTE 6:

TIME JITTER IS MEASURED AT THE 50 PERCENT POINT ON THE ANODE CURRENT PULSE.

ADDITIONAL INFORMATION FOR SPECIFIC APPLICATIONS CAN BE OBTAINED FROM THE

ELECTRON TUBE APPLICATIONS SECTION
ITT COMPONENTS DIVISION
POST OFFICE BOX 412
CLIFTON, NEW JERSEY

OUTLINE

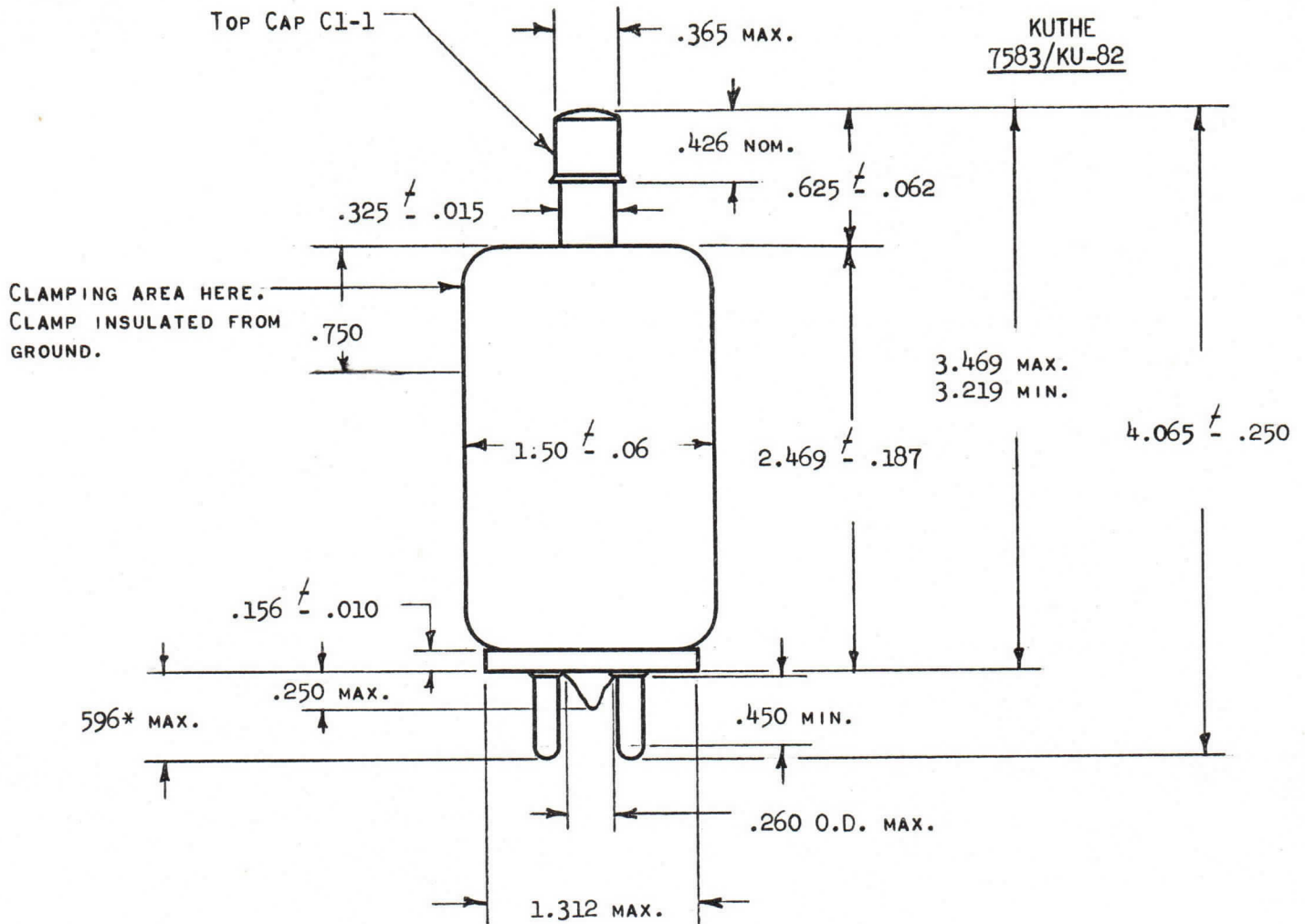

OUTLINE

* ON FINISHED TUBE ADD .030 FOR SOLDER

KUTHE KU-82

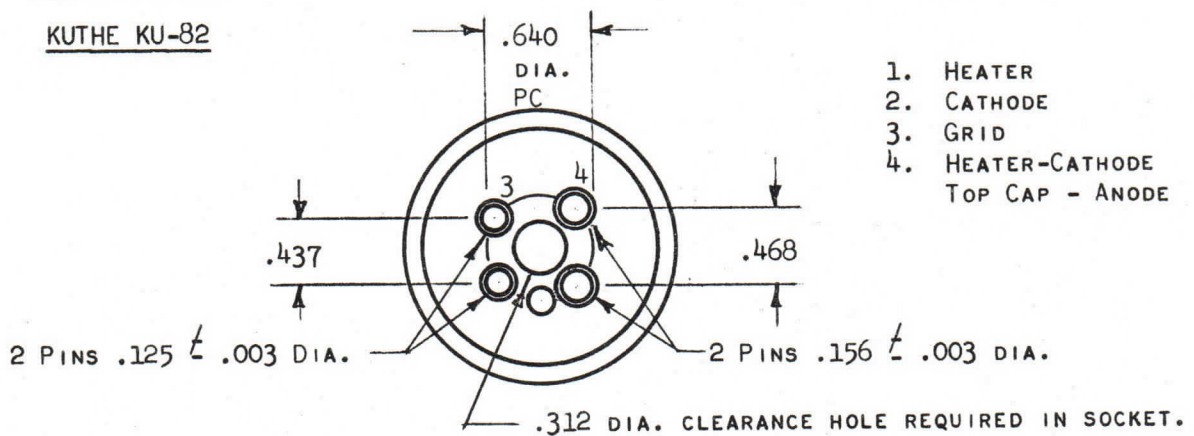

WAFER BASE. PIN ARRANGEMENT AND DIMENSIONS ONLY AS PER A4-9 MIL-E-1C



DESCRIPTION

The Type 7590 is a three element unipotential cathode hydrogen thyatron designed for "crow-bar" service. This tube is equipped with a hydrogen reservoir for maximum dependability.

GENERAL CHARACTERISTICS

Electrical	Nom.	Min.	Max.	
Heater Voltage	6.3	6.0	6.6	Volts AC
Heater Current (at 6.3 volts)		12.0	22.0	Amperes
Reservoir Voltage (Note 1)		2.5	5.5	Volts
* Reservoir Current at 4.5 Volts		2.0	5.0	Amperes
Minimum Heating Time			3	Minutes

Mechanical			
Mounting Position			Any
Base			See Outline
Cooling (Note 2)			
Net Weight		1.5	Pounds
Dimensions			Per Outline

MAXIMUM RATINGS

Max. Peak Anode Voltage, Forward, Transient (Note 3)	30.0	Kilovolts
Max. Peak Anode Voltage, Forward, Operating	25.0	Kilovolts
Max. Peak Anode Voltage, Inverse	15.0	Kilovolts
Min. Anode Supply Voltage	10.0	Kilovolts DC
Max. Peak Anode Current	1000	Amperes
* Max. Average Anode Current (Note 4)	500	Milliamperes
Averaging Time	10	Seconds
Max. Discharge Time (Note 4)	0.1	Seconds
Max. Anode Current Rate of Rise	2500	Amps / μ sec.
* Peak Trigger Voltage (Note 5)		
Max. Anode Delay Time	1.0	Microseconds
Ambient Temperature	-55° to +75°	

Note 1:

Adjust reservoir voltage to value indicated on tube within $\pm 5\%$.

Note 2:

No cooling required.

Note 3:

The maximum peak forward transient anode voltage rating applies to a transient voltage condition wherein the duration of the transient does not exceed two seconds.

Note 4:

The allowable time of discharge varies with the current as shown
Filter Discharge Period 0 - 1.5 ms.

Rectifier Short Circuit Period	1.5 - 100 ms	25 a
Rectifier Short Circuit Period	1.5 - 50 ms	50 a
Rectifier Short Circuit Period	1.5 - 30 ms	85 a

Time will be measured from the initiation of the discharge.

* Indicates change from data sheet dated 6-61

7590
HYDROGEN
THYRATRON
TUBE

Note 5:

The driver pulse measured at the tube socket with the thyatron grid disconnected shall be: $e_{gy} = 550$ Volts minimum, 2500 Volts maximum; Rate of Rise 1800 Volts per Microsecond; $t_p = 2.0$ Microseconds minimum; Impedance of Driver Circuit 50 - 200 Ohms.

Additional information for specific applications can be obtained from the

Electron Tube Applications Section
ITT Electron Tube Division
P. O. Box 100
Easton, Pennsylvania

Indicates change from data sheet dated 6-61

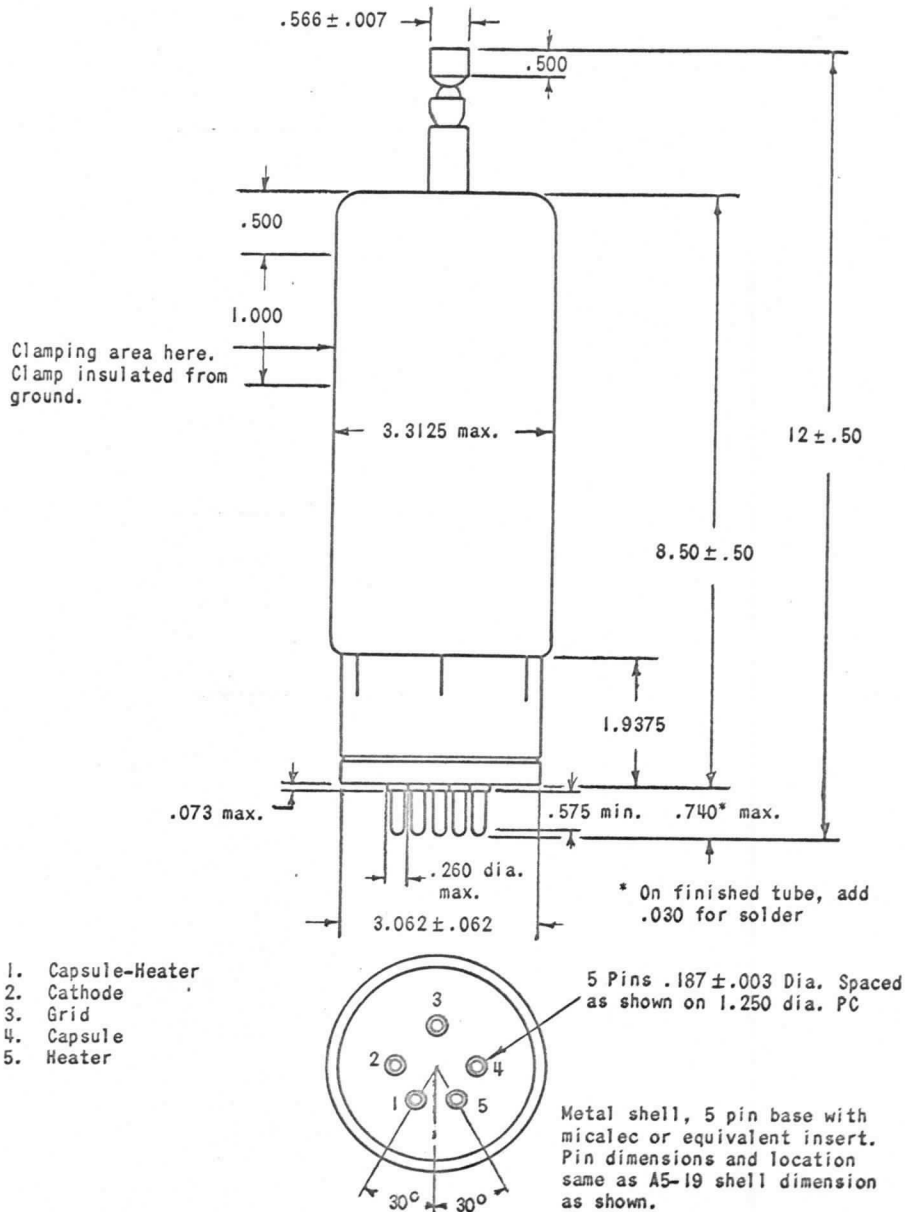

OUTLINE 7590



ELECTRON TUBE DIVISION

CLIFTON, NEW JERSEY

INTERNATIONAL TELEPHONE AND TELEGRAPH CORPORATION

KUTHE
TYPE 7603

CROWBAR THYRATRON

DESCRIPTION:

THE TYPE 7603 IS A HYDROGEN THYRATRON DESIGNED FOR CROWBAR SERVICE. THIS TUBE IS EQUIPPED WITH A HYDROGEN RESERVOIR FOR MAXIMUM DEPENDABILITY. THIS TUBE WAS PREVIOUSLY DESIGNATED BY THE TYPE NUMBER KU-401.

ELECTRICAL DATA, GENERAL:

	<u>NOM.</u>	<u>MIN.</u>	<u>MAX.</u>	
HEATER VOLTAGE	6.3	6.0	6.6	VOLTS AC
HEATER CURRENT (AT 6.3 VOLTS)		5.5	6.7	AMPERES
MINIMUM HEATING TIME			3	MINUTES

MECHANICAL DATA, GENERAL:

MOUNTING POSITION	ANY
BASE	SEE OUTLINE
COOLING	NOT REQUIRED
NET WEIGHT	8 OUNCES
DIMENSIONS	PER OUTLINE

RATINGS:

MAX. PEAK ANODE VOLTAGE, FORWARD, OPERATING	10.0	KILOVOLTS
MAX. PEAK ANODE VOLTAGE, INVERSE	8.0	KILOVOLTS
MIN. ANODE SUPPLY VOLTAGE	4.0	KILOVOLTS DC
MAX. PEAK ANODE CURRENT (NOTE 1)	200	AMPERES
AVERAGING TIME	10	SECONDS
MAX. DISCHARGE TIME (NOTE 1)	0.1	SECONDS
PEAK TRIGGER VOLTAGE (NOTE 2)		
MAX. ANODE DELAY TIME	1.0	MICROSECONDS
AMBIENT TEMPERATURE	-55° TO +75°	C

KUTHE
TYPE 7603

- 2 -

NOTE 1:

THE ALLOWABLE TIME OF DISCHARGE VARIES WITH THE CURRENT AS SHOWN:

RECTIFIER SHORT CIRCUIT PERIOD	1.5	-	100 MS	5A
" " " "	1.5	-	50 MS	10A
" " " "	1.5	-	30 MS	25A
FILTER DISCHARGE	0	-	1.5 MS	200A

TIME WILL BE MEASURED FROM THE INITIATION OF THE DISCHARGE.

NOTE 2:

THE TRIGGER PULSE MEASURED AT THE TUBE SOCKET WITH THE THYRATRON GRID DISCONNECTED SHALL BE: EGY = 175 VOLTS MINIMUM, 1,000 VOLTS MAXIMUM; TIME OF RISE = 0.5 US (MAX.); TP = 2.0 US MINIMUM; IMPEDANCE OF TRIGGER CIRCUIT 50 - 1,500 OHMS.

ADDITIONAL INFORMATION FOR SPECIFIC APPLICATIONS CAN BE OBTAINED FROM THE -

ELECTRON TUBE APPLICATIONS SECTION
ITT COMPONENTS DIVISION
POST OFFICE BOX 412
CLIFTON, NEW JERSEY

KUTHE
7603

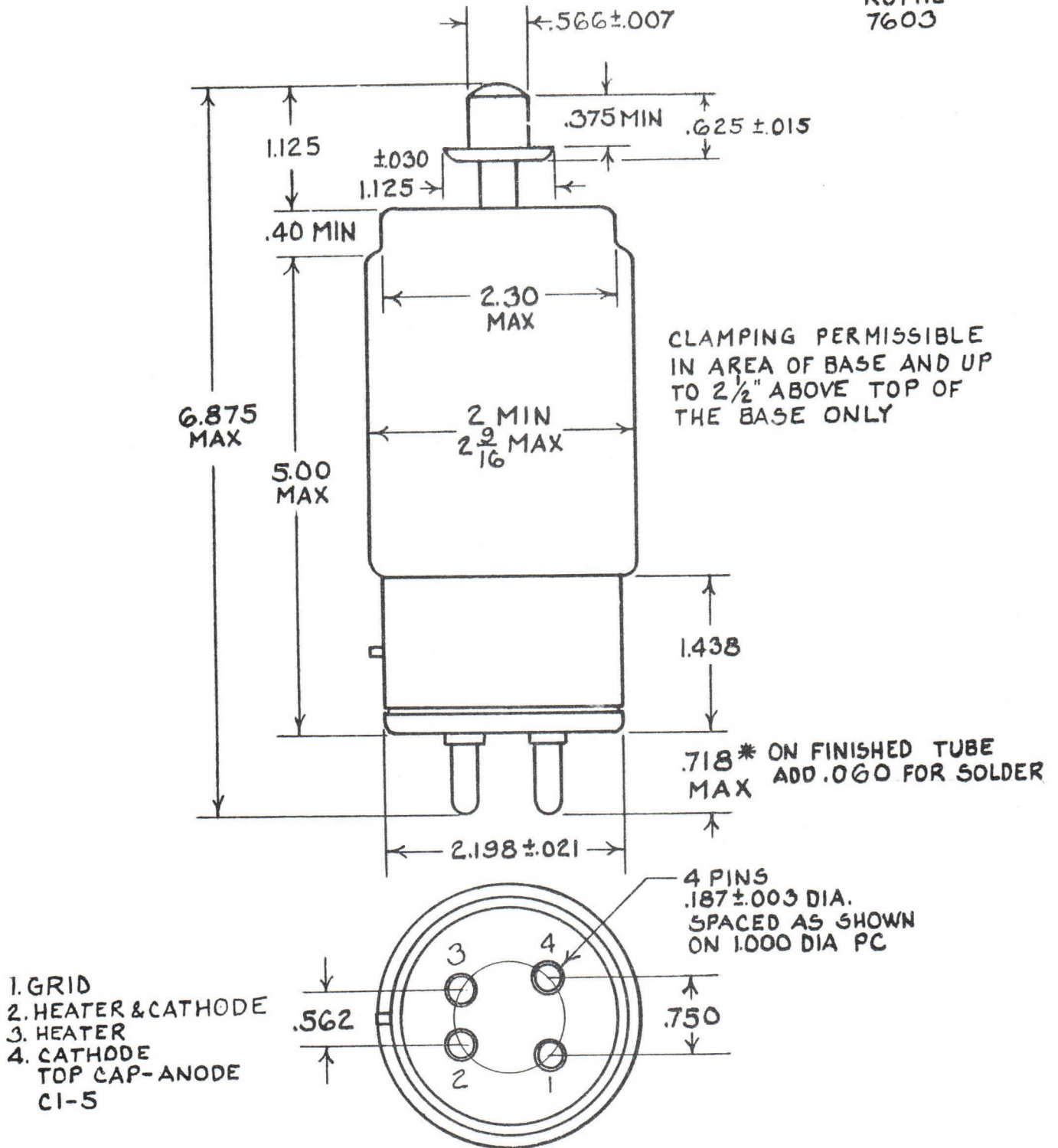

SUPER JUMBO 4-PIN WITH BAYONET
A4-18 MIL-E-ID WITH CERAMIC INSERT



ELECTRON TUBE DIVISION

CLIFTON, NEW JERSEY

INTERNATIONAL TELEPHONE AND TELEGRAPH CORPORATION



ELECTRON TUBE DIVISION

INTERNATIONAL TELEPHONE AND TELEGRAPH CORPORATION

BOX 100 EASTON, PA. 18043

**7665
HYDROGEN
THYRATRON

CERAMIC HYDROGEN THYRATRON

DESCRIPTION:

The 7665 is a unipotential cathode three element hydrogen thyatron equipped with a ceramic envelope. This electron tube features a hydrogen reservoir which may be connected directly across the cathode heater supply.

The ruggedness and small size possible with ceramic construction suits this thyatron to the compact modulators of high performance radars.

ELECTRICAL DATA, GENERAL

	<u>Nom.</u>	<u>Min.</u>	<u>Max.</u>	
Heater Voltage	6.3	5.8	6.8	Volts a.c.
*Heater Current (at 6.3 volts) Heater (Note 1)	6.0	5.5	6.5	Amperes
*Reservoir Voltage (Note 2)	6.3	5.8	6.8	Volts a.c.
*Reservoir Current at 6.3 Volt	1.5	1.0	2.0	Amperes
*Minimum Heating Time		3		Minutes

MECHANICAL DATA, GENERAL

Mounting Position	Any
Base	Per Outline Dwg.
Cooling (Note 3)	
Net Weight	0.5 Pounds
Dimensions	Per Outline

RATINGS:

Max. Peak Anode Voltage, forward	20.0	Kilovolts
Max. Peak Anode Voltage, inverse (Note 4)	20.0	Kilovolts
*Min. Anode supply voltage	1.0	Kilovolts d.c.
Max. Peak anode current	350	Amperes
Max. Average anode current	500	Milliamperes
Max. RMS anode current (Note 5)	6.5	Amperes a.c.
Max. $e_{py} \times i_b \times p_{rr}$	7.0×10^9	
Max. Anode current rate of rise	2000	Amps./ μ sec.
Peak trigger voltage (Note 6)		
Max. Anode delay time (Note 7)	0.4	Microsecond
Max. Anode delay time drift	0.1	Microsecond
Max. Time jitter (Note 8)	.005	Microsecond
Ambient Temperature	-55° to + 150°	C

*Indicates changes from data sheet dated 8-61

**This tube was previously designated by the Type Number KU-72

NOTE: Change in outline drawing from that of 7/62

KUTHE
7665

Note 1:

See outline drawing.

Note 2:

Reservoir connected externally to cathode heater when tube installation is made in equipment.

Note 3:

Cooling of the anode is permissible.

Note 4:

During the first 25 microseconds after conduction, the peak inverse anode voltage shall not exceed 5 kv.

Note 5:

The root mean square anode current shall be computed as the square root of the product of peak current and the average current.

Note 6:

The pulse produced by the driver circuit shall have the following characteristics when viewed at the 7665 socket with the tube grid disconnected.

A. Amplitude	200-500 Volts
B. Duration	2 Microseconds (at 70% points)
C. Rate of Rise	1800 Volts/Microsecond (min.)
D. Impedance	50-500 Ohms

The limits of anode time delay and anode time jitter are based on the minimum trigger. Using the highest permissible trigger voltage and lowest trigger source impedance materially reduces these values below the limits specified.

Note 7:

The time of anode delay is measured between the 26 percent point on the rising portion of the unloaded grid voltage pulse and the point at which anode conduction first evidences itself on the loaded grid pulse.

Note 8:

Time jitter is measured at the 50 percent point on the anode current pulse.

Additional information for specific applications can be obtained from the

Electron Tube Applications Section
ITT Electron Tube Division
Post Office Box 100
Easton, Pennsylvania 18043

-3-

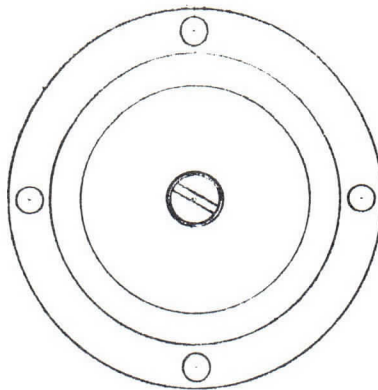

1.750 DIA.

ANODE CONN. #8.32 SCREW

2.45 ± .02

COMMON HEATER & CATHODE CONNECTION & MOUNTING FLANGE .030 THICK

.26 ± .02



1-1/4 MIN. CLEARANCE REQ'D.

(4) MTG HOLES FOR 6-32 SCREW
90° SPACING ON 2.031 CIRCLE

RESERVOIR LEAD 6" LONG, RED, LUG FOR #10 SCREW

CATHODE HEATER LEAD 6" LONG, YELLOW, LUG FOR #10 SCREW



GRID LEAD 6" LONG, GREEN, LUG FOR #10 SCREW

1-1/2 DIA.
MIN. CLEARANCE

2.250 DIA.

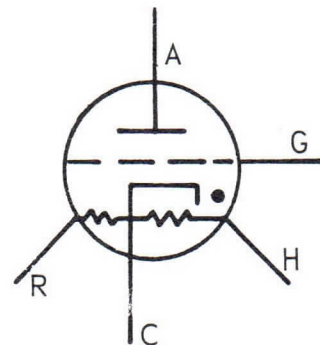

OUTLINE 7665

2-64

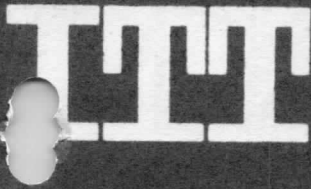

CERAMIC HYDROGEN THYRATRON

DESCRIPTION:

THE 7666 IS A 12.5 MEGAWATT, LARGE CERAMIC HYDROGEN THYRATRON. THE CERAMIC EXTERNAL ANODE DESIGN PERMITS OPERATION AT UNUSUALLY HIGH POWER LEVELS. THE SPECIAL FEATURES OF THE 7666 INCLUDE A HYDROGEN RESERVOIR TO MAINTAIN OPTIMUM PRESSURE AND TO INSURE LONG LIFE.

ELECTRICAL DATA, GENERAL:

	NOM.	MIN.	MAX.	
HEATER VOLTAGE	6.3	5.8	6.8	VOLTS A.C.
HEATER CURRENT (AT 6.3 VOLTS)		14.0	22.0	AMPERES
HEATER (NOTE 1)				
RESERVOIR VOLTAGE (NOTE 2)		2.5	6.0	VOLTS
RESERVOIR CURRENT AT 4.5 VOLT		4.0	6.0	AMPERES
MINIMUM HEATING TIME				5 MINUTES

MECHANICAL DATA, GENERAL:

MOUNTING POSITION	VERTICAL ONLY, BASE DOWN
BASE	PER OUTLINE
COOLING (NOTE 3)	
NET WEIGHT	3.0 POUNDS
DIMENSIONS (SEE OUTLINE DRAWING)	

RATINGS:

MAX. PEAK ANODE VOLTAGE, FORWARD	25	KILOVOLTS
MAX. PEAK ANODE VOLTAGE, INVERSE (NOTE 4)	25	KILOVOLTS
MIN. ANODE SUPPLY VOLTAGE	5.0	KILOVOLTS D.C.
* MAX. PEAK ANODE CURRENT	1500	AMPERES
MAX. AVERAGE ANODE CURRENT	1.5	AMPERES
MAX. RMS ANODE CURRENT (NOTE 5)	40.0	AMPERES A.C.
MAX. EPY x IB x PRR	20.0 x 109	
MAX. ANODE CURRENT RATE OF RISE	5000	AMPS./U SEC.
PEAK TRIGGER VOLTAGE (NOTE 6)		
MAX. PEAK INVERSE TRIGGER VOLTAGE	650	VOLTS
MAX. ANODE DELAY TIME (NOTE 7)	0.4	MICROSECOND
MAX. ANODE DELAY TIME DRIFT	0.25	MICROSECOND
MAX. TIME JITTER (NOTE 8)	0.005	MICROSECOND
AMBIENT TEMPERATURE	-55° TO 125°	C

* INDICATES CHANGE FROM DATA SHEET DATED 7-62

** THIS TUBE WAS PREVIOUSLY DESIGNATED BY THE TYPE NUMBER KU-73.

NOTE 1:

SEE OUTLINE DRAWING.

NOTE 2:

THE OPTIMUM RESERVOIR VOLTAGE FOR OPERATION IN ACCORDANCE WITH OPERATION (1) CONDITIONS IS INSCRIBED ON THE BASE OF THE TUBE AND MUST BE HELD TO WITHIN $\pm 7.5\%$. APPLICATIONS INVOLVING OTHER OPERATING CONDITIONS WILL NECESSITATE THE REDETERMINATION OF THE OPTIMUM RESERVOIR VOLTAGE. OPERATION (1) CONDITIONS (25 KV - 1000 A - 2.5 US - 300 PPS).

NOTE 3:

IT MAY BE DESIRABLE TO EMPLOY FORCED AIR COOLING UNDER CONDITIONS OF HIGH PB NUMBER OPERATIONS. A COOLING AIR BLAST OF 10 CFM MAY BE DIRECTED INTO THE ANODE CUP.

NOTE 4:

IN PULSED OPERATION, THE PEAK INVERSE VOLTAGE, EXCLUSIVE OF A SPIKE OF .05 US MAXIMUM DURATION, SHALL NOT EXCEED 5.0 KV DURING THE FIRST 25 US FOLLOWING THE ANODE PULSE.

NOTE 5:

THE ROOT MEAN SQUARE ANODE CURRENT SHALL BE COMPUTED AS THE SQUARE ROOT OF THE PRODUCT OF PEAK CURRENT AND THE AVERAGE CURRENT.

NOTE 6:

THE DRIVER PULSE, MEASURED AT TUBE SOCKET WITH THYRATRON GRID DISCONNECTED: 550 VOLTS MINIMUM, 1000 VOLTS MAXIMUM; TR = 0.35 US MAXIMUM; GRID PULSE DURATION 2.0 US MINIMUM. IMPEDANCE OF DRIVE CIRCUIT 50 TO 200 OHMS.

NOTE 7:

THE TIME OF ANODE DELAY IS MEASURED BETWEEN THE 26 PERCENT POINT ON THE RISING PORTION OF THE UNLOADED GRID VOLTAGE PULSE AND THE POINT AT WHICH ANODE CONDUCTION FIRST EVIDENCES ITSELF ON THE LOADED GRID PULSE.

NOTE 8:

TIME JITTER IS MEASURED AT THE 50 PERCENT POINT ON THE ANODE CURRENT PULSE.

ADDITIONAL INFORMATION FOR SPECIFIC APPLICATIONS CAN BE OBTAINED FROM THE

ITT COMPONENTS DIVISION
ELECTRON TUBE APPLICATIONS SECTION
POST OFFICE BOX 412
CLIFTON, NEW JERSEY

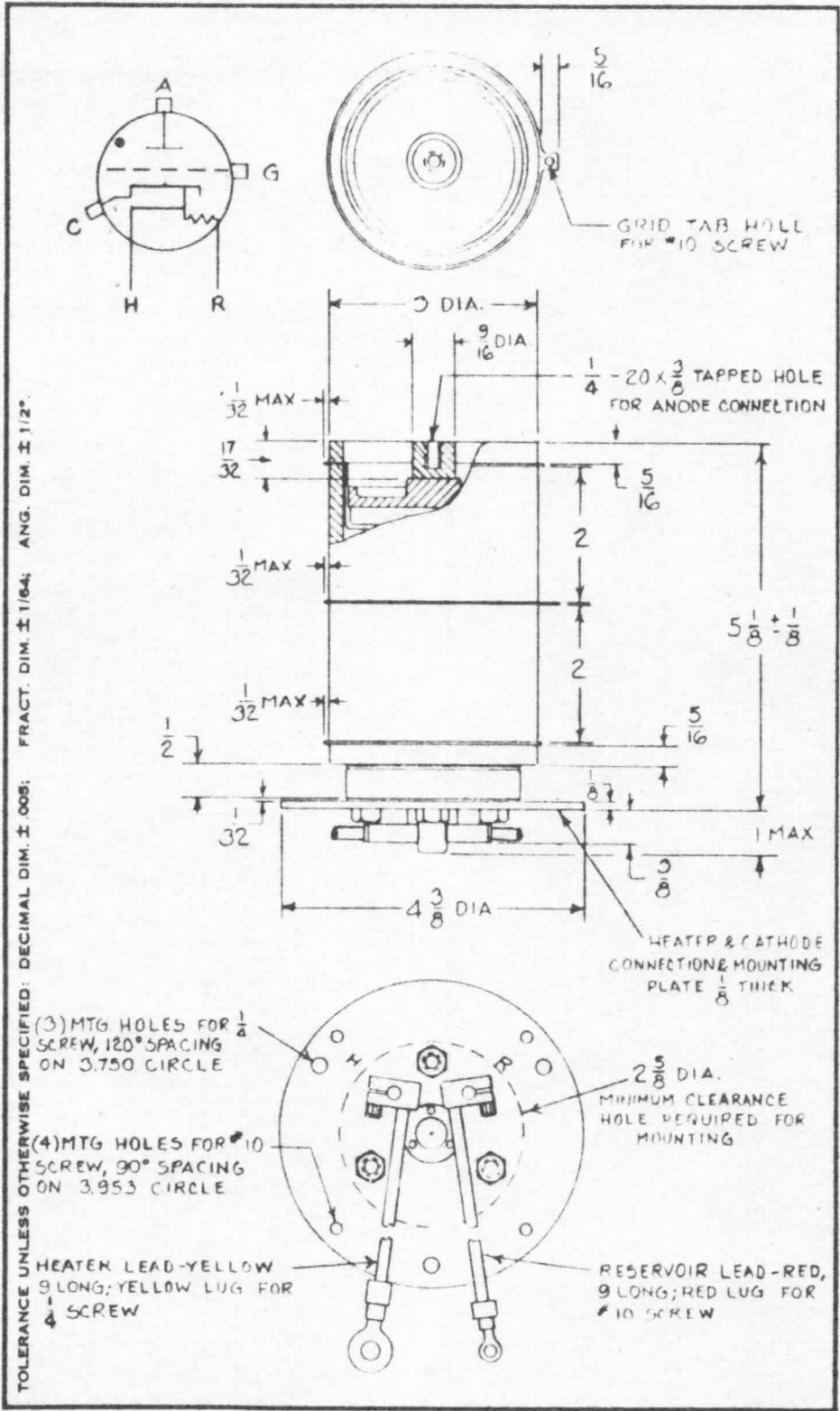

TOLERANCE UNLESS OTHERWISE SPECIFIED: DECIMAL DIM. $\pm .005$; FRACT. DIM. $\pm 1/64$; ANG. DIM. $\pm 1/2^\circ$.

OUTLINE 7666



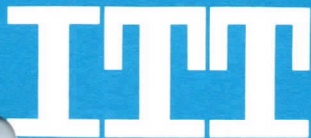

CERAMIC HYDROGEN THYRATRON

DESCRIPTION:

- * THE 7667 IS A 40 MEGAWATT, LARGE CERAMIC HYDROGEN THYRATRON. THE CERAMIC EXTERNAL ANODE DESIGN PERMITS OPERATION AT UNUSUALLY HIGH POWER LEVELS. THE SPECIAL FEATURES OF THE 7667 INCLUDE A HYDROGEN RESERVOIR TO MAINTAIN OPTIMUM PRESSURE AND TO INSURE LONG LIFE.

ELECTRICAL DATA, GENERAL:

	Nom.	MIN.	MAX.	
HEATER VOLTAGE	6.3	5.8	6.8	VOLTS A.C.
HEATER CURRENT (AT 6.3 VOLTS) HEATER (NOTE 1)		25.0	40.0	AMPERES
RESERVOIR VOLTAGE (NOTE 2)		3.5	5.5	VOLTS
* RESERVOIR CURRENT AT 4.5 VOLT		8.0	20.0	AMPERES
MINIMUM HEATING TIME				10 MINUTES

MECHANICAL DATA, GENERAL:

MOUNTING POSITION	VERTICAL ONLY, BASE DOWN
BASE (PER OUTLINE)	
COOLING (NOTE 3)	
NET WEIGHT	11.5 POUNDS
DIMENSIONS (SEE OUTLINE DRAWING)	

RATINGS:

MAX. PEAK ANODE VOLTAGE, FORWARD	33.0	KILOVOLTS
MAX. PEAK ANODE VOLTAGE, INVERSE (NOTE 4)	33.0	KILOVOLTS
MIN. ANODE SUPPLY VOLTAGE	2.5	KILOVOLTS D.C.
* MAX. PEAK ANODE CURRENT	2400	AMPERES
MAX. AVERAGE ANODE CURRENT	4.0	AMPERES
MAX. RMS ANODE CURRENT (NOTE 5)	90	AMPERES A.C.
MAX. EPY X IB X PRR	40 x 10 ⁹	
MAX. ANODE CURRENT RATE OF RISE	10,000	AMPS./U SEC.
PEAK TRIGGER VOLTAGE (NOTE 6)		
MAX. PEAK INVERSE TRIGGER VOLTAGE	750	VOLTS
MAX. ANODE DELAY TIME (NOTE 7)	0.4	MICROSECOND
MAX. ANODE DELAY TIME DRIFT	0.25	MICROSECOND
MAX. TIME JITTER (NOTE 8)	.005	MICROSECOND
AMBIENT TEMPERATURE	-55° TO / 150°	C

- * INDICATES CHANGES FROM DATA SHEET DATED 10-60.
- ** THIS TUBE WAS PREVIOUSLY DESIGNATED BY THE TYPE NUMBER KU-74.

NOTE 1:

CATHODE CONNECTED TO CENTER OF CATHODE HEATER.

NOTE 2:

RESERVOIR VOLTAGE IS MARKED ON THE BASE OF EACH 7667/KU-74. THIS IS THE CORRECT VOLTAGE FOR ONE TYPICAL OPERATING CONDITION BUT IS NOT THE OPTIMUM VALUE FOR ALL TYPES OF OPERATION. THIS VALUE MAY BE USED INITIALLY IN NEW APPLICATIONS AND THE OPTIMUM VALUE MAY THEN BE OBTAINED BY EXPLORING THE RANGE OF VOLTAGE ON EITHER SIDE OF THAT MARKED ON THE TUBE. EXCESS RESERVOIR VOLTAGE WILL RESULT IN A FAILURE OF THE THYRATRON TO DEIONIZE BETWEEN PULSES (CONTINUOUS CONDUCTION). INSUFFICIENT RESERVOIR VOLTAGE WILL RESULT IN EXCESS ANODE DISSIPATION AS INDICATED BY HEATING OF THE ANODE. THE OPTIMUM RESERVOIR VOLTAGE IS THE MIDPOINT BETWEEN THESE TWO EXTREMES. IN CERTAIN APPLICATIONS IT MAY BE NECESSARY TO PROVIDE A REGULATED SOURCE TO ASSURE OPERATION WITHIN THE PERMISSIBLE RANGE OF RESERVOIR VOLTAGES.

NOTE 3:

COOLING OF THE ANODE IS PERMISSIBLE.

NOTE 4:

DURING THE FIRST 25 MICROSECONDS AFTER CONDUCTION, THE PEAK INVERSE ANODE VOLTAGE SHALL NOT EXCEED 5 KV.

NOTE 5:

THE ROOT MEAN SQUARE ANODE CURRENT SHALL BE COMPUTED AS THE SQUARE ROOT OF THE PRODUCT OF PEAK CURRENT AND THE AVERAGE CURRENT.

NOTE 6:

THE PULSE PRODUCED BY THE DRIVER CIRCUIT SHALL HAVE THE FOLLOWING CHARACTERISTICS WHEN VIEWED AT THE 7667/KU-74 SOCKET WITH THE TUBE REMOVED.

A. AMPLITUDE	750-2500 VOLTS
B. DURATION	2 MICROSECONDS (AT 70% POINTS)
C. TIME OF RISE	0.35 MICROSECONDS (MAX.)
D. IMPEDANCE	10-25 OHMS

THE LIMITS OF ANODE TIME DELAY AND ANODE TIME JITTER ARE BASED ON THE MINIMUM TRIGGER. USING THE HIGHEST PERMISSIBLE TRIGGER VOLTAGE AND LOWEST TRIGGER SOURCE IMPEDANCE MATERIALLY REDUCES THESE VALUES BELOW THE LIMITS SPECIFIED.

NOTE 7:

THE TIME OF ANODE DELAY IS MEASURED BETWEEN THE 26 PER CENT POINT ON THE RISING PORTION OF THE UNLOADED GRID VOLTAGE PULSE AND THE POINT AT WHICH ANODE CONDUCTION FIRST EVIDENCES ITSELF ON THE LOADED GRID PULSE.

NOTE 8:

TIME JITTER IS MEASURED AT THE 50% POINT ON THE ANODE CURRENT PULSE.

ADDITIONAL INFORMATION FOR SPECIFIC APPLICATIONS CAN BE OBTAINED FROM THE

ELECTRON TUBE APPLICATIONS SECTION, ITT COMPONENTS DIVISION.
POST OFFICE BOX 412, CLIFTON, NEW JERSEY

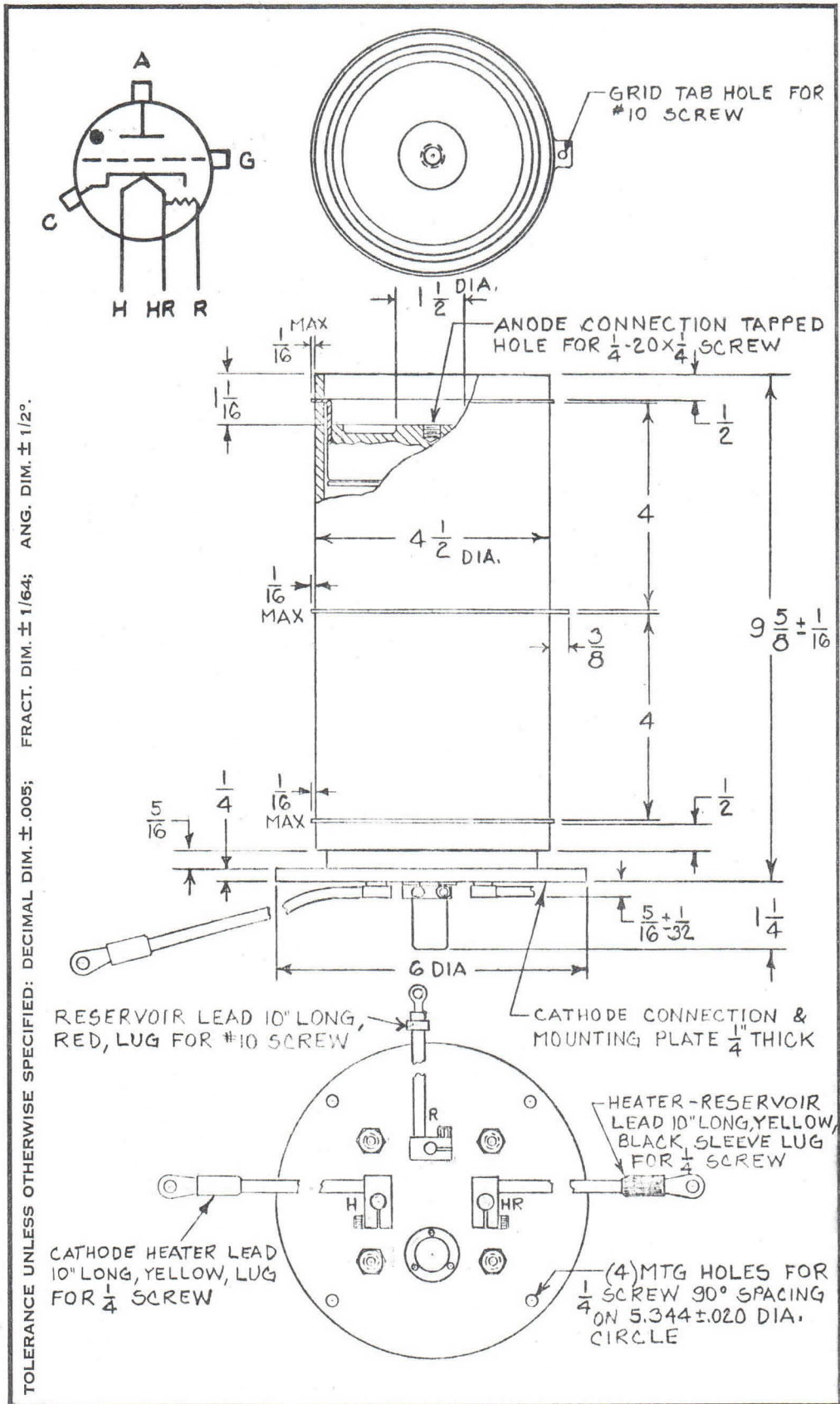

OUTLINE 7667

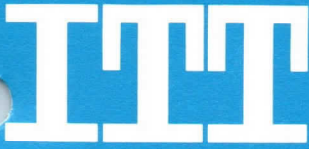

CERAMIC HYDROGEN THYRATRON

DESCRIPTION:

THE 7782/KU-71 IS A UNIPOTENTIAL CATHODE THREE ELEMENT HYDROGEN THYRATRON OF CERAMIC METAL CONSTRUCTION DESIGNED FOR USE IN COMPACT MODULATORS FOR HIGH PERFORMANCE RADARS AND FOR MISSILE APPLICATIONS.

ELECTRICAL DATA, GENERAL:

	<u>Nom.</u>	<u>MIN.</u>	<u>MAX.</u>	
HEATER VOLTAGE	6.3	5.8	6.8	VOLTS A.C.
* HEATER CURRENT (AT 6.3 VOLTS)	5.5	3.5	7.0	AMPERES
* RESERVOIR VOLTAGE	6.3	5.8	6.8	VOLTS A.C.
* RESERVOIR CURRENT (AT 6.3 VOLTS)	1.5	1.0	2.5	AMPERES
* MINIMUM HEATING TIME		3		MINUTES

MECHANICAL DATA, GENERAL:

MOUNTING POSITION ANY
DIMENSIONS PER OUTLINE

RATINGS:

* MAX. PEAK ANODE VOLTAGE, FORWARD	12.0	KILOVOLTS
* MAX. PEAK ANODE VOLTAGE, INVERSE (NOTE 1)	12.0	KILOVOLTS
MIN. ANODE SUPPLY VOLTAGE	0.3	KILOVOLTS D.C.
MAX. PEAK ANODE CURRENT	200.0	AMPERES
MAX. AVERAGE ANODE CURRENT	200.0	MILLIAMPERES
MAX. RMS ANODE CURRENT (NOTE 2)	5.0	AMPERES A.C.
MAX. EBY X IBX X PRR (PB)	4.0 x 10 ⁹	
MAX. ANODE CURRENT, RATE OF RISE	2000	AMPS./U SEC.
PEAK TRIGGER VOLTAGE (NOTE 3)		
MAX. PEAK INVERSE TRIGGER VOLTAGE	200	VOLTS
MAX. ANODE DELAY TIME (NOTE 4)	0.50	U SECOND
MAX. ANODE DELAY TIME DRIFT	0.10	U SECOND
MAX. TIME JITTER (NOTE 5)	.005	U SECOND
AMBIENT TEMPERATURE	-50° TO 150°	C
SHOCK RATING	500	G.
VIBRATION	30	G.

* INDICATES CHANGES FROM DATA SHEET DATED 10-60

** THIS TUBE WAS PREVIOUSLY DESIGNATED BY THE TYPE NUMBER KU-71.

NOTE 1:

THE PEAK INVERSE VOLTAGE SHOULD NOT EXCEED 2.5 KV DURING THE FIRST 25 MICROSECONDS AFTER THE PULSE.

NOTE 2:

THE ROOT MEAN SQUARE ANODE CURRENT SHALL BE COMPUTED AS THE SQUARE ROOT OF THE PRODUCT OF THE PEAK CURRENT AND THE AVERAGE CURRENT.

NOTE 3:

THE DRIVER PULSE, MEASURED AT THE TUBE SOCKET WITH THE THYRATRON GRID DISCONNECTED SHOULD HAVE THE FOLLOWING CHARACTERISTICS:

- | | |
|-----------------|---------------------------------------|
| A. VOLTAGE | 175 VOLTS (MIN.) |
| B. DURATION | 2 MICROSECONDS (AT 70 PERCENT POINTS) |
| C. IMPEDANCE | 1500 OHMS (MAX.) |
| D. TIME OF RISE | 0.5 MICROSECOND (MAX.) |

THE LIMITS OF ANODE TIME DELAY AND ANODE TIME JITTER ARE BASED ON THE MINIMUM TRIGGER. USING THE HIGHEST PERMISSIBLE TRIGGER VOLTAGE AND LOWEST TRIGGER SOURCE IMPEDANCE MATERIALLY REDUCES THESE VALUES BELOW THE LIMITS SPECIFIED.

NOTE 4:

THE TIME OF ANODE DELAY IS MEASURED BETWEEN THE 26 PERCENT POINT ON THE RISING PORTION OF THE UNLOADED GRID VOLTAGE PULSE AND THE POINT AT WHICH EVIDENCE OF ANODE CONDUCTION FIRST APPEARS ON THE LOADED GRID PULSE.

NOTE 5:

TIME JITTER IS MEASURED AT THE 50 PERCENT POINT ON THE ANODE CURRENT PULSE.

ADDITIONAL INFORMATION FOR SPECIFIC APPLICATIONS CAN BE OBTAINED FROM THE

ELECTRON TUBE APPLICATIONS SECTION
ITT COMPONENTS DIVISION
POST OFFICE BOX 412
CLIFTON, NEW JERSEY

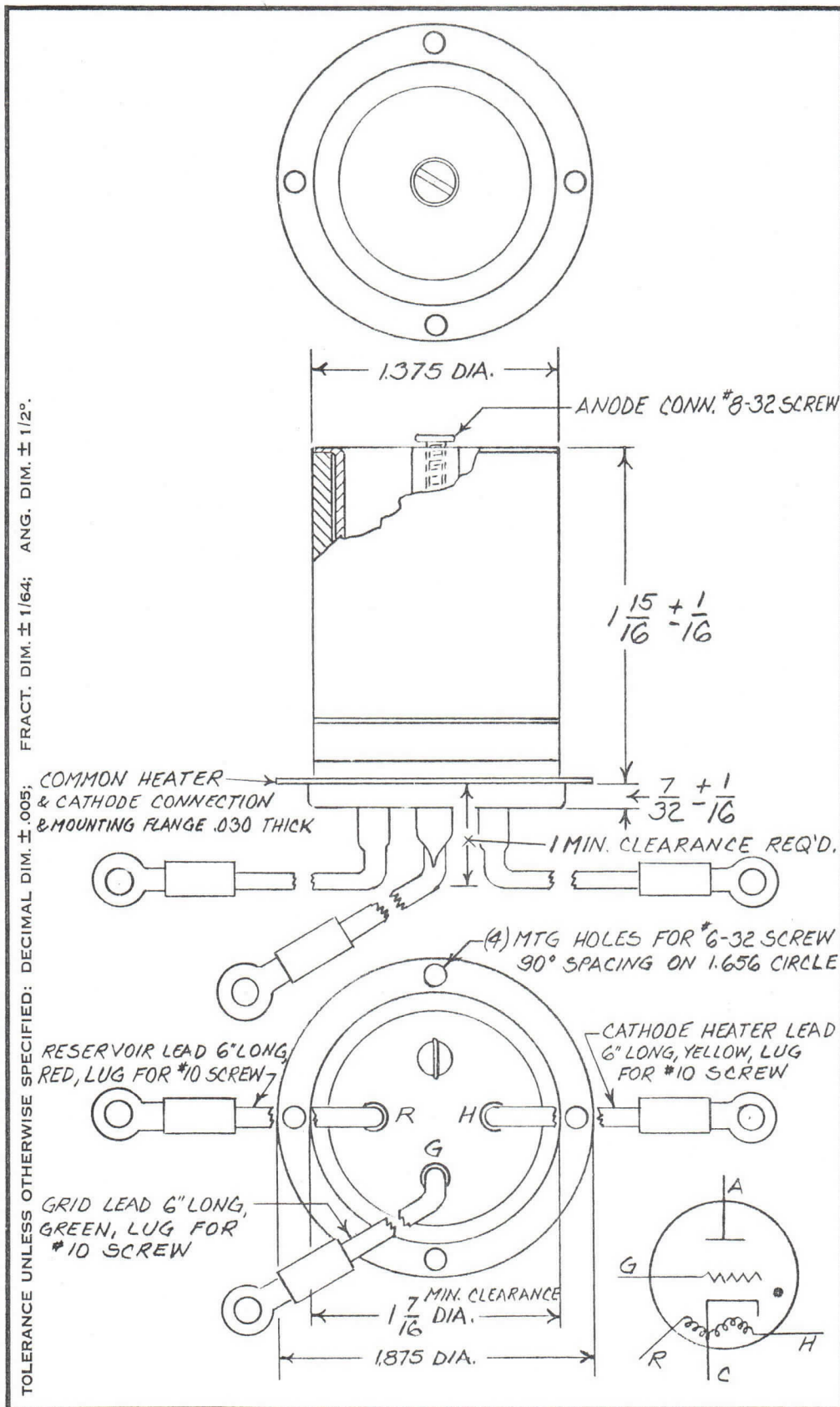

OUTLINE 7782



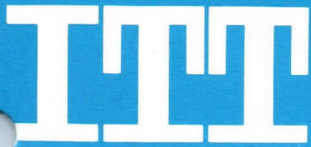

CERAMIC HYDROGEN THYRATRON

DESCRIPTION:

* THE 7866/KU-274 IS A 60 MEGAWATT PEAK TETRODE TYPE CERAMIC ENVELOPE HYDROGEN THYRATRON. GREAT CARE HAS BEEN EXERCISED IN THE DESIGN OF THIS TUBE IN ORDER TO INSURE AN EQUAL DISTRIBUTION OF CAPACITY ACROSS THE GAPS. THIS MAKES THE USE OF COMPENSATING CAPACITORS UNNECESSARY. PROVISION FOR LIQUID COOLING OF THE ANODE IS PROVIDED FOR OPERATION AT HEAT FACTORS ABOVE 40×10^9 .

ELECTRICAL DATA, GENERAL:

	<u>NOM.</u>	<u>MIN.</u>	<u>MAX.</u>	
HEATER VOLTAGE	6.3	5.8	6.8	VOLTS AC
HEATER CURRENT (AT 6.3 VOLTS)		25.0	35.0	AMPERES
HEATER (NOTE 1)				
RESERVOIR VOLTAGE (NOTE 2)		3.5	5.5	VOLTS
* RESERVOIR CURRENT AT 4.5 VOLTS		8.0	20.0	AMPERES
MINIMUM HEATING TIME				10 MINUTES

MECHANICAL DATA, GENERAL:

MOUNTING POSITION	VERTICAL ONLY, BASE DOWN
BASE (PER OUTLINE)	
COOLING (NOTE 3)	
NET WEIGHT	15 POUNDS
DIMENSIONS (SEE OUTLINE DRAWING)	

RATINGS:

MAX. PEAK ANODE VOLTAGE, FORWARD	50.0	KILOVOLTS
MAX. PEAK ANODE VOLTAGE, INVERSE (NOTE 4)	50.0	KILOVOLTS
MIN. ANODE SUPPLY VOLTAGE (NOTE 5)	2.5	KILOVOLTS
MAX. PEAK ANODE CURRENT	2400	AMPERES
MAX. AVERAGE ANODE CURRENT	4.0	AMPERES
MAX. RMS ANODE CURRENT (NOTE 6)	90	AMPERES AC
MAX. EPY X IB X PRR	55×10^9	
MAX. ANODE CURRENT RATE OF RISE	10,000	AMPS./U SEC
PEAK TRIGGER VOLTAGE (NOTE 7)		
MAX. PEAK INVERSE TRIGGER VOLTAGE	650	VOLTS
MAX. ANODE DELAY TIME (NOTE 8)	0.4	MICROSECOND
MAX. ANODE DELAY TIME DRIFT	* 0.1	MICROSECOND
MAX. TIME JITTER (NOTE 9)	.005	MICROSECOND
AMBIENT TEMPERATURE	-55° TO / 150°	C

* INDICATES CHANGES FROM DATA SHEET DATED 6-61

** THIS TUBE WAS PREVIOUSLY DESIGNATED BY THE TYPE NUMBER KU-274.

NOTE 1:

CATHODE CONNECTED TO CENTER OF CATHODE HEATER.

NOTE 2:

RESERVOIR VOLTAGE IS MARKED ON THE BASE OF EACH 7866/KU-274. THIS IS THE CORRECT VOLTAGE FOR ONE TYPICAL OPERATING CONDITION BUT IS NOT THE OPTIMUM VALUE FOR ALL TYPES OF OPERATION. THIS VALUE MAY BE USED INITIALLY IN NEW APPLICATIONS AND THE OPTIMUM VALUE MAY THEN BE OBTAINED BY EXPLORING THE RANGE OF VOLTAGE ON EITHER SIDE OF THAT MARKED ON THE TUBE. EXCESS RESERVOIR VOLTAGE WILL RESULT IN A FAILURE OF THE THYRATRON TO DEIONIZE BETWEEN PULSES (CONTINUOUS CONDUCTION). INSUFFICIENT RESERVOIR VOLTAGE WILL RESULT IN EXCESS ANODE DISSIPATION AS INDICATED BY HEATING OF THE ANODE. THE ANODE DISSIPATION MUST NOT BE PERMITTED TO EXCEED 1500 WATTS AS MEASURED IN THE COOLING WATER. A USEFUL FORMULA FOR THIS DETERMINATION FOLLOWS:

$$P = 264 Q_w (T_2 - T_1)$$

P = POWER IN WATTS
Q_w = FLOW IN GALLONS/MINUTE
T₂ - T₁ = OUTLET AND INLET WATER TEMPERATURES IN DEGREES KELVIN, RESPECTIVELY

THE OPTIMUM RESERVOIR VOLTAGE IS THE MIDPOINT BETWEEN THESE TWO EXTREMES. IN CERTAIN APPLICATIONS IT MAY BE NECESSARY TO PROVIDE A REGULATED SOURCE TO ASSURE OPERATION WITHIN THE PERMISSIBLE RANGE OF RESERVOIR VOLTAGES.

NOTE 3:

COOLING OF THE ANODE IS REQUIRED FOR OPERATION AT HEAT FACTORS ABOVE 30×10^9 . ABOVE THIS VALUE, FORCED COOLING IS NECESSARY. THIS MAY BE ACCOMPLISHED BY AIRBLAST INTO THE ANODE CUP FOR MODEST REQUIREMENTS (10 CFM), BY COMPRESSED AIR DIRECTED THROUGH THE COOLING CHAMBER, AND BY LIQUID COOLANTS CIRCULATED THROUGH THE COOLING CHAMBER. A MINIMUM FLOW OF 1 GALLON PER MINUTE OF WATER IS REQUIRED. THE WATER INLET TEMPERATURE SHALL NOT BE LESS THAN 5°C, NOR THE OUTLET TEMPERATURE HIGHER THAN 95°C. MAXIMUM WATER PRESSURE UNDER A NORMAL CONDITION IS 50 PSI (100 PSI MAY BE TOLERATED FOR SHORT PERIODS). PRESSURE DROP IS APPROXIMATELY 1 PSI.

NOTE 4:

DURING THE FIRST 25 MICROSECONDS AFTER CONDUCTION, THE PEAK INVERSE ANODE VOLTAGE SHALL NOT EXCEED 10 KV.

NOTE 5:

A RESISTANCE DIVIDER OF 40 MEGOHMS SHALL BE CONNECTED BETWEEN ANODE AND CATHODE. THE CENTER TOP OF THIS DIVIDER WILL BE CONNECTED TO THE SECOND OR GRADIENT GRID OF THE 7866. IT IS RECOMMENDED THAT THIS ARRANGEMENT BE EMPLOYED WHETHER LOW VOLTAGE OPERATION IS REQUIRED OR NOT. THIS DIVIDER IS A NECESSITY FOR KEYED GRID OPERATION.

NOTE 6:

THE ROOT MEAN SQUARE ANODE CURRENT SHALL BE COMPUTED AS THE SQUARE ROOT OF THE PRODUCT OF PEAK CURRENT AND THE AVERAGE CURRENT.

NOTE 7:

THE PULSE PRODUCED BY THE DRIVER CIRCUIT SHALL HAVE THE FOLLOWING CHARACTERISTICS WHEN VIEWED AT THE 7667/KU-74 SOCKET WITH THE TUBE REMOVED.

A. AMPLITUDE	750 - 2500 VOLTS
B. DURATION	2 MICROSECONDS (AT 70% POINTS)
C. TIME OF RISE	0.35 MICROSECONDS (MIN.)
D. IMPEDANCE	10 - 25 OHMS

THE LIMITS OF ANODE TIME DELAY AND ANODE TIME JITTER ARE BASED ON THE MINIMUM TRIGGER. USING THE HIGHEST PERMISSIBLE TRIGGER VOLTAGE AND LOWEST TRIGGER SOURCE IMPEDANCE MATERIALLY REDUCES THESE VALUES BELOW THE LIMITS SPECIFIED.

NOTE 8:

THE TIME OF ANODE DELAY IS MEASURED BETWEEN THE 26 PER CENT POINT ON THE RISING PORTION OF THE UNLOADED GRID VOLTAGE PULSE AND THE POINT AT WHICH ANODE CONDUCTION FIRST EVIDENCES ITSELF ON THE LOADED GRID PULSE.

NOTE 9:

TIME JITTER IS MEASURED AT THE 50% POINT ON THE ANODE CURRENT PULSE.

ADDITIONAL INFORMATION FOR SPECIFIC APPLICATIONS CAN BE OBTAINED FROM THE

ELECTRON TUBE APPLICATIONS SECTION
ITT COMPONENTS DIVISION
Post Office Box 412
CLIFTON, NEW JERSEY



ANODE TERMINAL
 1/4-20x1/2 LG. RH BRASS SCREW N.P. OUTLINE
 1/4 BRASS WASHER 1/2 O.D. N.P. 7866

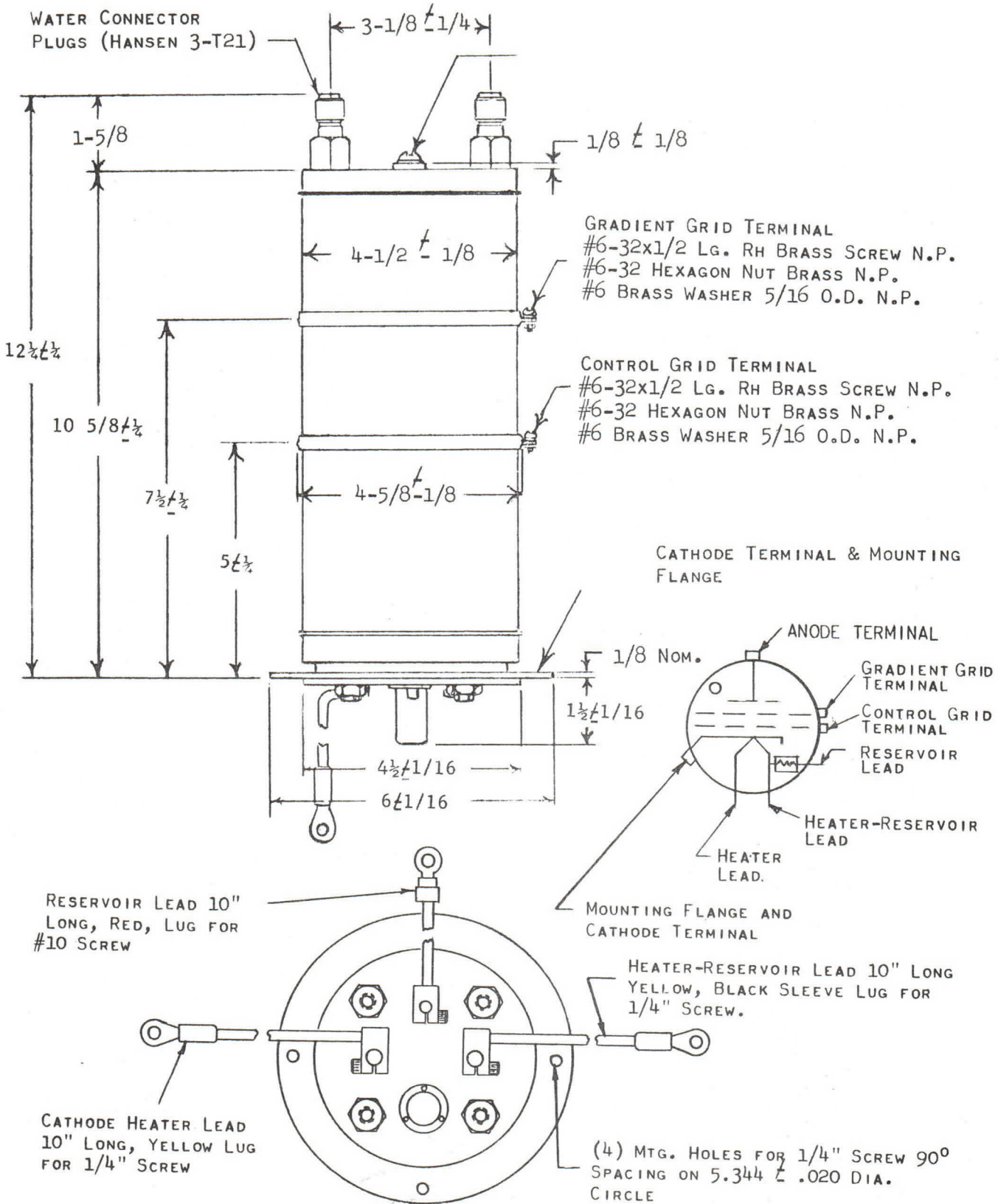

OUTLINE - 7866



TENTATIVE

SUPER-POWER CERAMIC HYDROGEN THYRATRON

DESCRIPTION:

The 8301 is a 100 megawatt ceramic hydrogen thyatron. The anode and grid structures may be liquid cooled to permit operation at an average output power level of 200 kilowatts. Special features of the 8301 include a balanced capacity gradient grid design for optimum operation and a maximum planar cathode area for long life. This tube was previously designated by the type number KU-275.

ELECTRICAL DATA, GENERAL

	<u>Nom.</u>	<u>Min.</u>	<u>Max.</u>	
Heater Voltage	6.3	6.0	6.6	Volts AC
Heater Current (At 6.3 Volts)		40	100	Amperes
Heater (Note 1)				
Reservoir Voltage (Note 2)		3.5	6.0	Volts
Reservoir Current at 5.5 Volts		20.0	60.0	Amperes
Minimum Heating Time			15	Minutes

MECHANICAL DATA, GENERAL

Mounting Position	Vertical Only, Base Down		
Base (Per Outline)	Flange		
Cooling (Note 3)			
Net Weight		41	Pounds
Dimensions (See Outline Drawing)	Seated Height:	16	Inches

RATINGS:

Max. Peak Anode Voltage, Forward	50.0	Kilovolts
Max. Peak Anode Voltage, Inverse (Note 4)	50.0	Kilovolts
Min. Anode Supply Voltage (Note 5)	5.0	Kilovolts
Max. Peak Anode Current	4000	Amperes
Max. Average Anode Current	8.0	Amperes DC
Max. RMS Anode Current (Note 6)	125	Amperes AC
Max. Epy X ib X prr	400×10^9	
Max. Anode Current Rate of Rise	10,000	Amps./ μ Sec.
Peak Trigger Voltage (Note 7)		
Ambient Temperature	-55° to +90°	C

Note 1:

Cathode connected to center of cathode heater.

Note 2:

Reservoir voltage is marked on the base of each 8301. This is the correct voltage for one typical operating condition but is not the optimum value for all types of operation. This value may be used initially in new applications and the optimum value may then be obtained by exploring the range of voltage on either side of that marked on the tube. Excess reservoir voltage will result in a failure of the thyratron to deionize between pulses (continuous conduction). Insufficient reservoir voltage will result in excess anode dissipation as indicated by heating of the anode. The anode dissipation must not be permitted to exceed 2000 watts as measured in the cooling water. A useful formula for this determination follows:

$$P = 264 QW (T_2 - T_1)$$

P = Power in Watts

QW = Flow in Gallons/Minute

T₂ - T₁ = Outlet and Inlet Water Temperatures in Degrees Kelvin, Respectively

The optimum reservoir voltage is the midpoint between these two extremes. In certain applications it may be necessary to provide a regulated source to assure operation within the permissible range of reservoir voltages.

Note 3:

Cooling of the grid and anode is normally required. This may be accomplished by liquid coolants circulated through the cooling chambers. A minimum flow of 1 gallon per minute of water is required. The water inlet temperature shall not be less than 5°C, nor the outlet temperature higher than 95°C.

Note 4:

During the first 25 microseconds after conduction, the peak inverse anode voltage shall not exceed 10 KV.

Note 5:

A resistance divider of 40 megohms shall be connected between anode and cathode. The center tap of this divider will be connected to the second or gradient grid of the 8301. It is recommended that this arrangement be employed whether low voltage operation is required or not. This divider is a necessity for keyed grid operation.

Note 6:

The root mean square anode current shall be computed as the square root of the product of peak current and the average current.

Note 7:

The pulse produced by the driver circuit shall have the following characteristics when viewed at the 8301 socket with the tube removed.

- | | |
|-----------------|--------------------------------|
| A. Amplitude | 2000 - 4000 Volts |
| B. Duration | 2 Microseconds (At 70% Points) |
| C. Time of Rise | 0.35 Microseconds (Min.) |
| D. Impedance | 10 - 25 Ohms |

The limits of anode time delay and anode time jitter are based on the minimum trigger. Using the highest permissible trigger voltage and lowest trigger source impedance materially reduces these values below the limits specified.

Additional information for specific applications can be obtained from the -

Electron Tube Applications Section
ITT Electron Tube Division
Post Office Box 104
Clifton, New Jersey

TOLERANCE: $\pm \frac{1}{4}$

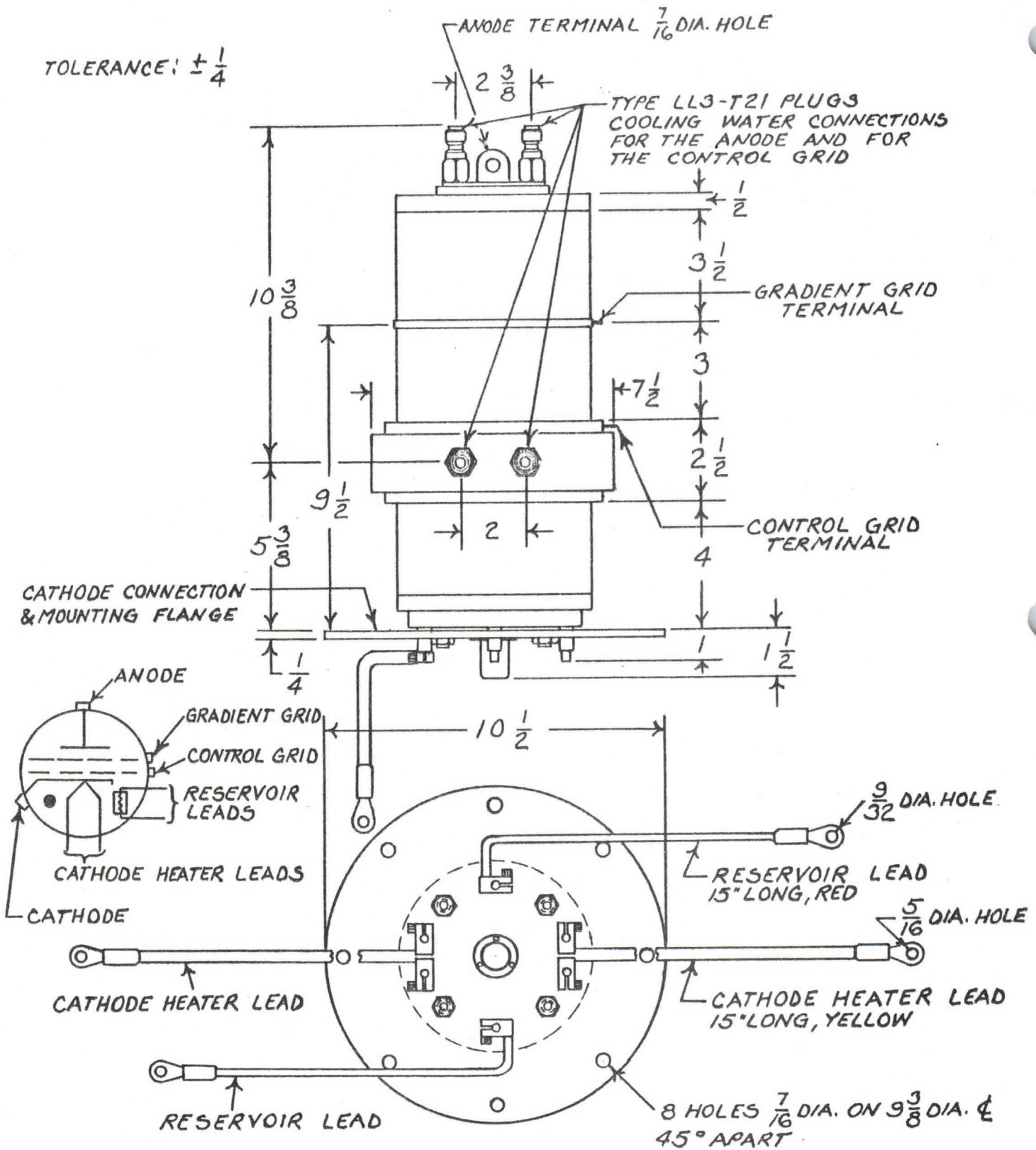

OUTLINE 8301/KU275

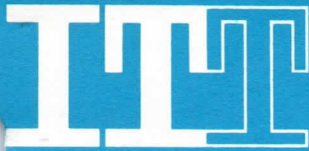

TENTATIVE

CERAMIC HYDROGEN DIODE

DESCRIPTION:

THE KU-92 IS A CERAMIC ENVELOPE, INDIRECTLY HEATED, HYDROGEN FILLED DIODE FOR USE IN HIGH VOLTAGE RECTIFIER AND CLIPPER CIRCUITS. THIS TUBE, EQUIPPED WITH A HYDROGEN RESERVOIR WILL GIVE EXCELLENT RESULTS UNDER SEVERE ENVIRONMENTAL SERVICE.

THE INHERENT IMMUNITY FROM ELECTRICAL SURGE DAMAGE, AND RUGGED PHYSICAL CONSTRUCTION SUIT THIS DIODE TO COMPACT HIGH POWER RECTIFIERS AND MODULATORS.

ELECTRICAL DATA, GENERAL:

	<u>Nom.</u>	<u>MIN.</u>	<u>Max.</u>	
HEATER VOLTAGE	5.0	4.7	5.3	VOLTS AC
HEATER CURRENT (AT 5.0 VOLTS)		7.5	9.5	AMPERES
HEATER (NOTE 1)				
RESERVOIR VOLTAGE (NOTE 2)		4.7	5.3	VOLTS
RESERVOIR CURRENT AT 5.0 VOLTS		1.0	3.0	AMPERES
MINIMUM HEATING TIME				3 MINUTES

MECHANICAL DATA, GENERAL:

* MOUNTING POSITION (NOTE 3)	ANY
BASE	PER OUTLINE DWG.
COOLING (NOTE 4)	
NET WEIGHT	0.6 POUNDS
DIMENSIONS	PER OUTLINE

MAXIMUM RATINGS:

	<u>RECTIFIER</u>	<u>CLIPPER</u>	<u>BACK SWING DIODE</u>	
PEAK INVERSE ANODE VOLTAGE	15.0	20.0	20.0	KILOVOLTS
PEAK ANODE CURRENT	3.0	300	300	AMPERES
AVERAGE ANODE CURRENT	600	200	200	MILLIAMPERES
R.M.S. ANODE CURRENT	-	6.0	6.0	AMPERES
ANODE VOLTAGE DROP	70	250	250	VOLTS
INITIAL FIRING VOLTAGE (NOTE 5)	100	-	-	VOLTS
RECURRENT FIRING VOLTAGE	60	-	-	VOLTS
AMBIENT TEMPERATURE	- 55 TO 125 DEGREES			C

* INDICATES CHANGE FROM DATA SHEET DATED 6-61

NOTE 1:

SEE OUTLINE DRAWING FOR CONNECTIONS.

NOTE 2:

THE OPTIMUM RESERVOIR VOLTAGE FOR RECTIFIER AND PULSE TRANSFORMER BACKSWING CLIPPER SERVICE IS 5.0 VOLTS. THIS MAY BE OBTAINED BY DIRECT CONNECTION TO THE CATHODE HEATER SUPPLY. FOR USE IN CERTAIN TYPES OF INVERSE CLIPPER SERVICE, A RESERVOIR VOLTAGE SOMEWHAT HIGHER OR LOWER MAY BE REQUIRED.
(ERES 4.0 - 6.0 VOLTS)

NOTE 3:

* VERTICAL POSITION RECOMMENDED BUT NOT REQUIRED.

NOTE 4:

AIR BLAST COOLING (5 CFM) IS RECOMMENDED ABOUT THE BASE AND ANODE FOR OPERATION IN HIGH AMBIENT TEMPERATURE.

NOTE 5:

THE ROOT MEAN SQUARE ANODE CURRENT SHALL BE COMPUTED AS THE SQUARE ROOT OF THE PRODUCT OF PEAK AND THE AVERAGE CURRENT.

ADDITIONAL INFORMATION FOR SPECIFIC APPLICATIONS CAN BE OBTAINED FROM THE

ELECTRON TUBE APPLICATIONS SECTION
ITT COMPONENTS DIVISION
POST OFFICE BOX 412
CLIFTON, NEW JERSEY

* INDICATES CHANGE FROM DATA SHEET DATED 6-61

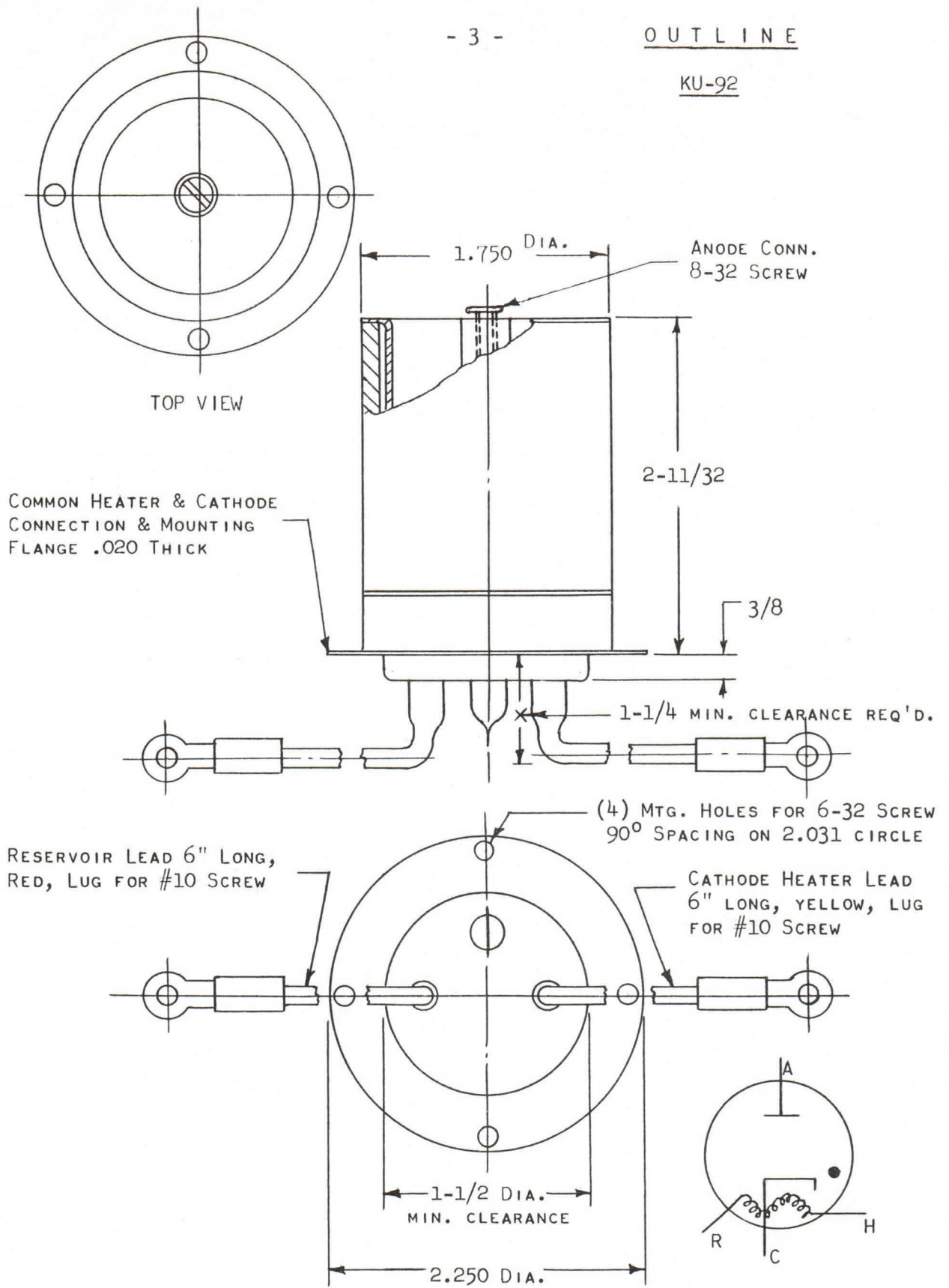

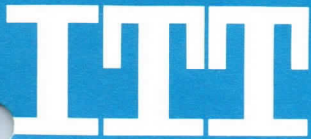

DESCRIPTION:

THE KU-99 IS A UNIPOTENTIAL CATHODE, THREE ELEMENT HYDROGEN FILLED THYRATRON DESIGNED FOR NETWORK DISCHARGE SERVICE. IN SUCH SERVICE, IT IS SUITABLE FOR PRODUCING PULSE OUTPUTS OF 55 KW AT AN AVERAGE POWER LEVEL OF MORE THAN 65 WATTS.

THE SPECIAL FEATURES OF THE KU-99 INCLUDE THE HIGH PEAK VOLTAGE AND CURRENT RATINGS, THE COMPACT SIZE, AND A RESERVOIR, CONNECTED INTERNALLY ACROSS THE FILAMENT, WHICH WILL MAINTAIN THE PRESSURE AT THE DESIRED VALUE THROUGHOUT THE USEFUL LIFE OF THE TUBE.

ELECTRICAL DATA, GENERAL:

	<u>NOM.</u>	<u>MIN.</u>	<u>MAX.</u>	
HEATER VOLTAGE	6.3	5.9	6.7	VOLTS A.C.
HEATER CURRENT (AT 6.3 VOLTS)		2.2	2.7	AMPERES
MINIMUM HEATING TIME				3 MINUTES

MECHANICAL DATA, GENERAL:

MOUNTING POSITION
BASE

ANY
MEDIUM, 4 PIN, LOW LOSS
PHENOLIC, A 4-9
SMALL METAL, C1-1

ANODE CAP
COOLING (NOTE 1)
NET WEIGHT
DIMENSIONS

2.5 OUNCES
SEE OUTLINE

RATINGS:

MAX. PEAK ANODE VOLTAGE, FORWARD	3.0	KILOVOLTS
MAX. PEAK ANODE VOLTAGE, INVERSE (NOTE 2)	3.0	KILOVOLTS
MIN. ANODE SUPPLY VOLTAGE	800	VOLTS D.C.
MAX. PEAK ANODE CURRENT	35	AMPERES
MAX. AVERAGE ANODE CURRENT	45	MILLIAMPERES
MAX. RMS ANODE CURRENT (NOTE 3)	1.25	AMPERES A.C.
MAX. EPY X IB X PRR	0.3 X 10 ⁹	
MAX. ANODE CURRENT RATE OF RISE	750	AMPERES/USECOND
PEAK TRIGGER VOLTAGE (NOTE 4)		
MAX. PEAK INVERSE TRIGGER VOLTAGE	200	VOLTS
MAX. ANODE DELAY TIME (NOTE 5)	0.6	MICROSECOND
MAX. ANODE DELAY TIME DRIFT	0.15	MICROSECOND
MAX. TIME JITTER (NOTE 6)	0.02	MICROSECOND
		(INITIAL)
	0.04	USECOND (END OF LIFE)
AMBIENT TEMPERATURE	-50° to +90°	CENT.

TYPICAL OPERATION AS PULSE MODULATOR, DC RESONANT CHARGING:

PEAK NETWORK VOLTAGE	3.0	KILOVOLTS
PULSE REPETITION RATE	2500	PULSES/SECOND
PULSE LENGTH	0.5	MICROSECOND
PULSE FORMING NETWORK IMPEDANCE	45.2	OHMS
TRIGGER VOLTAGE	200	VOLTS
PEAK POWER OUTPUT - (RESISTIVE LOAD 92% Z _N)	47.2	KILOWATTS
PEAK ANODE CURRENT	35	AMPERES
AVERAGE ANODE CURRENT	.044	AMPERES D.C.

NOTE 1:

COOLING OF THE ANODE LEAD IS PERMISSIBLE, BUT THERE SHALL BE NO AIR BLAST DIRECTLY ON THE BULB.

NOTE 2:

THE PEAK INVERSE VOLTAGE SHOULD NOT EXCEED 1.5 KV DURING THE FIRST 25 MICROSECONDS AFTER CONDUCTION.

NOTE 3:

THE ROOT MEAN SQUARE ANODE CURRENT SHALL BE COMPUTED AS THE SQUARE ROOT OF THE PRODUCT OF THE PEAK CURRENT AND THE AVERAGE CURRENT.

NOTE 4:

THE VOLTAGE BETWEEN GRID AND CATHODE TERMINALS OF THE SOCKET WITH THE TUBE REMOVED SHOULD HAVE THE FOLLOWING CHARACTERISTICS:

- | | |
|---------------------|-------------------------------|
| A. VOLTAGE | 175-250 VOLTS |
| B. DURATION | 2 MICROSECOND (AT 70% POINTS) |
| C. SOURCE IMPEDANCE | 1500 OHMS (MAX.) |
| D. RATE OF RISE | 200 VOLTS/MICROSECOND (MIN.) |

THE LIMITS OF ANODE TIME DELAY AND ANODE TIME JITTER ARE BASED ON THE MINIMUM TRIGGER. USING THE HIGHEST PERMISSIBLE TRIGGER VOLTAGE AND LOWEST TRIGGER SOURCE IMPEDANCE MATERIALLY REDUCES THESE VALUES BELOW THE LIMITS SPECIFIED.

NOTE 5:

THE TIME OF ANODE DELAY IS MEASURED BETWEEN THE 26 PERCENT POINT ON THE RISING PORTION OF THE UNLOADED GRID VOLTAGE PULSE AND THE POINT AT WHICH EVIDENCE OF ANODE CONDUCTION FIRST APPEARS ON THE LOADED GRID PULSE.

NOTE 6:

TIME JITTER IS MEASURED AT THE 50 PERCENT POINT ON THE ANODE CURRENT PULSE.

ADDITIONAL INFORMATION FOR SPECIFIC APPLICATIONS CAN BE OBTAINED FROM THE -

ELECTRON TUBE APPLICATIONS SECTION
ITT COMPONENTS DIVISION
POST OFFICE BOX 412
CLIFTON, NEW JERSEY

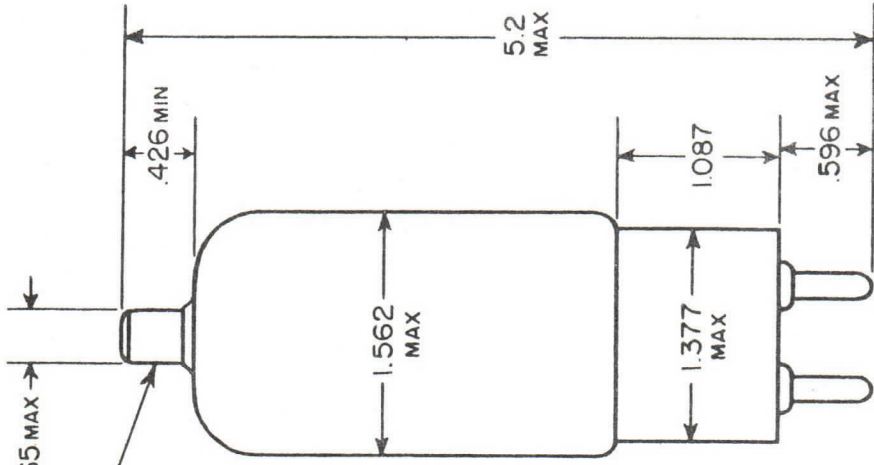

TOP CAP CI-1

CLAMPING IS PERMITTED BY THE BASE AND / OR BULB IN THE AREA UP TO 2" ABOVE THE TOP OF THE BASE ONLY

- 1. HEATER
- 2. CATHODE
- 3. GRID
- 4. HEATER & CATHODE

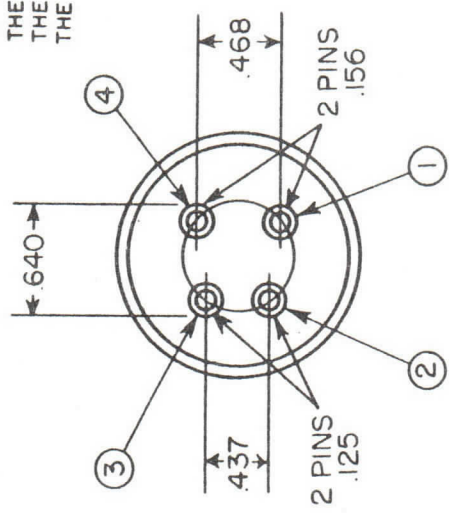

MEDIUM 4-PIN A4-9



ELECTRON TUBE DIVISION

INTERNATIONAL TELEPHONE AND TELEGRAPH CORPORATION

BOX 100 EASTON, PA. 18043

**F-1087
HYDROGEN
THYRATRON**

TENTATIVE

DESCRIPTION

The F-1087 is the first in a family of new generation hydrogen thyratrons, operating at levels of 100,000 volts or more. The F-1087 is a multigap metal-ceramic hydrogen thyatron capable of switching over 15 megawatts peak power at greater than 25 kilowatts average power at a peak forward voltage of 100,000 volts. It is a zero bias unit consisting of six elements designed for operation in oil. The novel iterative gradient grid structure of the tube produces favorable anode take-over time and relatively low minimum anode take-over voltage characteristics. Other features of the tube include a planar type oxide coated cathode and a titanium hydride reservoir which combine to produce long life with exceptional range stability.

GENERAL CHARACTERISTICS

Electrical Data

	Nom.	Min.	Max.	
Cathode Heater Voltage	6.3	5.8	6.8	Volts AC
Cathode Heater Current (at 6.3 volts)	6.0	5.5	6.5	Amperes AC
Reservoir Voltage	5.0	2.5	6.8	Volts AC
Reservoir Current (at 4.5v)		4.0	6.0	Amperes AC
Cathode and Reservoir Heaters (See Note 1)				
Minimum Heating Time		5		Minutes

Mechanical Data

Mounting Position		Any
Base (Per Outline)		Flange
Cooling/Insulation Medium		See Note 2
Net weight		1 - 1/4 Pounds
Dimensions (Per Outline)		Seated Height 6.25 Inches

MAXIMUM RATINGS

(See Note 3)

Max. Peak Anode voltage, Forward	100.0	Kilovolts
Min. Anode Supply voltage (Note 5)	5.0	Kilovolts DC
Max. Peak Anode Current	350	Amperes
Max. Average Anode Current	500	Milliamperes
Max. RMS Anode Current (Note 6)	7.0	Amperes AC
Max. $e_{py} \times i_b \times p_{rr}$	20×10^9	
Max. Anode Current Rate of Rise	2500	A/Microseconds
Peak Trigger Voltage		See Note 7
Max. Anode Delay Time (Note 8)	1.0	Microsecond
Max. Anode Delay Time Drift	0.10	Microsecond
Max. Time Jitter (Note 9)	0.005	Microsecond

WARNING: Operation of this tube may produce x-rays, which constitute a health hazard. Adequate rayproof shielding must therefore be provided in the equipment.

MAXIMUM RATINGS (Cont'd)

Note 1: See Outline Drawing, Figure 1.

Note 2: For operation above 25KV peak forward voltage the tube should be immersed in regular transformer insulating oil (Esso 35 or equivalent), Freon or sulfahexaflorine.

Provision should be made to cool the insulating medium so that the temperature is less than 50°C.

Note 3: Absolute values should not normally be allowed to occur simultaneously. For specific applications, consult the ITT Electron Tube Division, Applications Section.

Note 4: During the first 25 usec after conduction, the peak inverse voltage shall not exceed 20KV.

Note 5: A resistance divider of 40 megohms shall be connected between anode and cathode. The divider shall be tapped in four equal sections and connected to the tube per Figure 2. It is recommended that this arrangement be employed whether low voltage operation is required or not. This divider is a necessity for keyed grid operation.

Note 6: The root mean square anode current shall be computed as the square root of the product of peak current and the average current.

Note 7: The pulse produced by the driver circuit shall have the following characteristics when viewed at the F-1087 mounting plate with the tube grid disconnected:

A. Amplitude	200-500 volts
B. Duration	2 usec (at 70% Points)
C. Rate of Rise	0.35 usec (Max.)
D. Impedance	50-500 ohms

The limits of anode delay time, delay time drift, and time jitter are based on the minimum trigger. Using the highest permissible trigger voltage and the lowest trigger source impedance materially reduces those values below the limits specified.

Note 8: The time of anode delay is measured between the 26 percent point on the rising portion of the unloaded grid voltage pulse and the point at which anode conduction begins.

Note 9: Time jitter is measured at the 50% point on the leading edge of the current pulse.

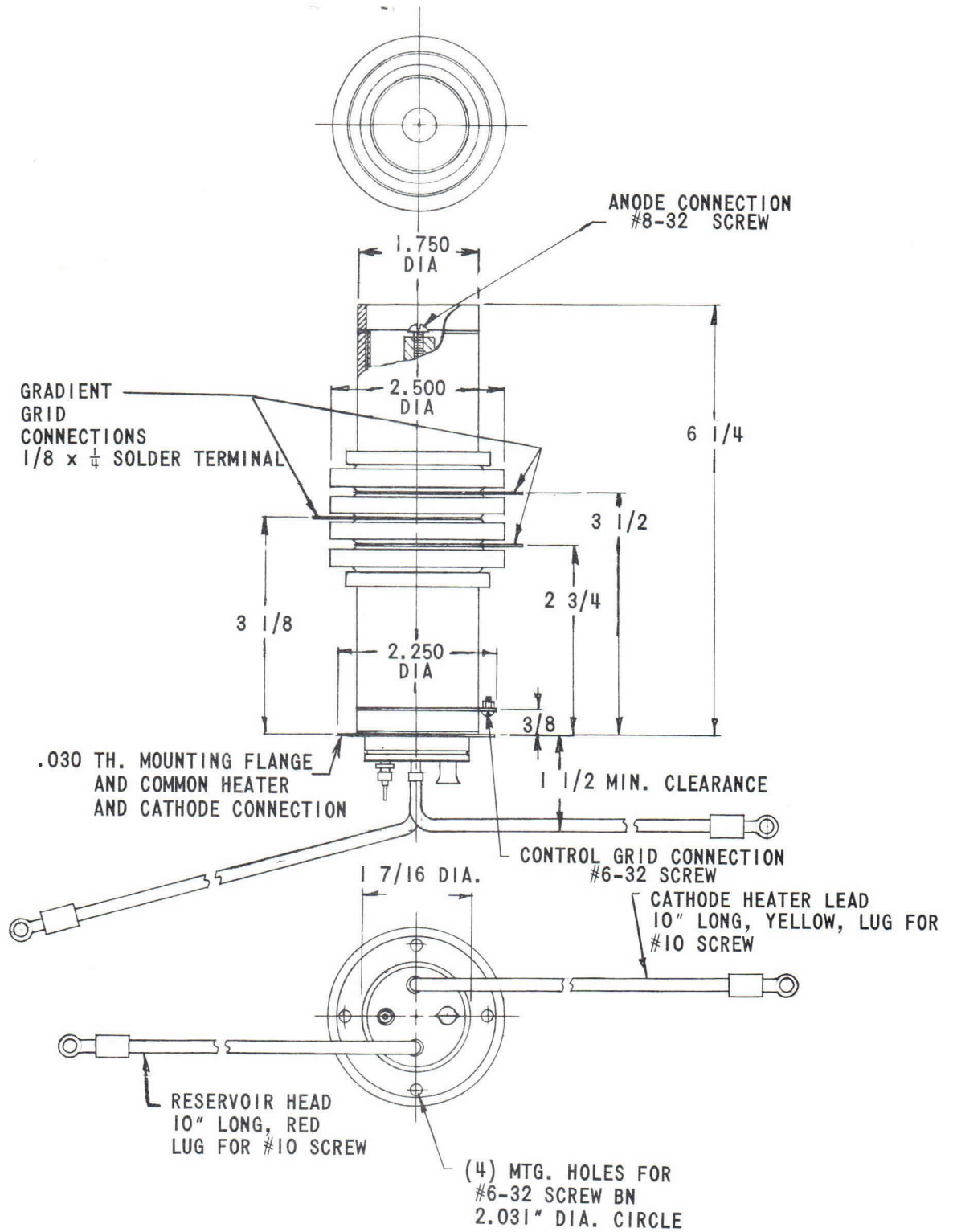

F-1087 OUTLINE
FIGURE 1



ELECTRON TUBE DIVISION

BOX 100 EASTON, PA. 18043

INTERNATIONAL TELEPHONE AND TELEGRAPH CORPORATION

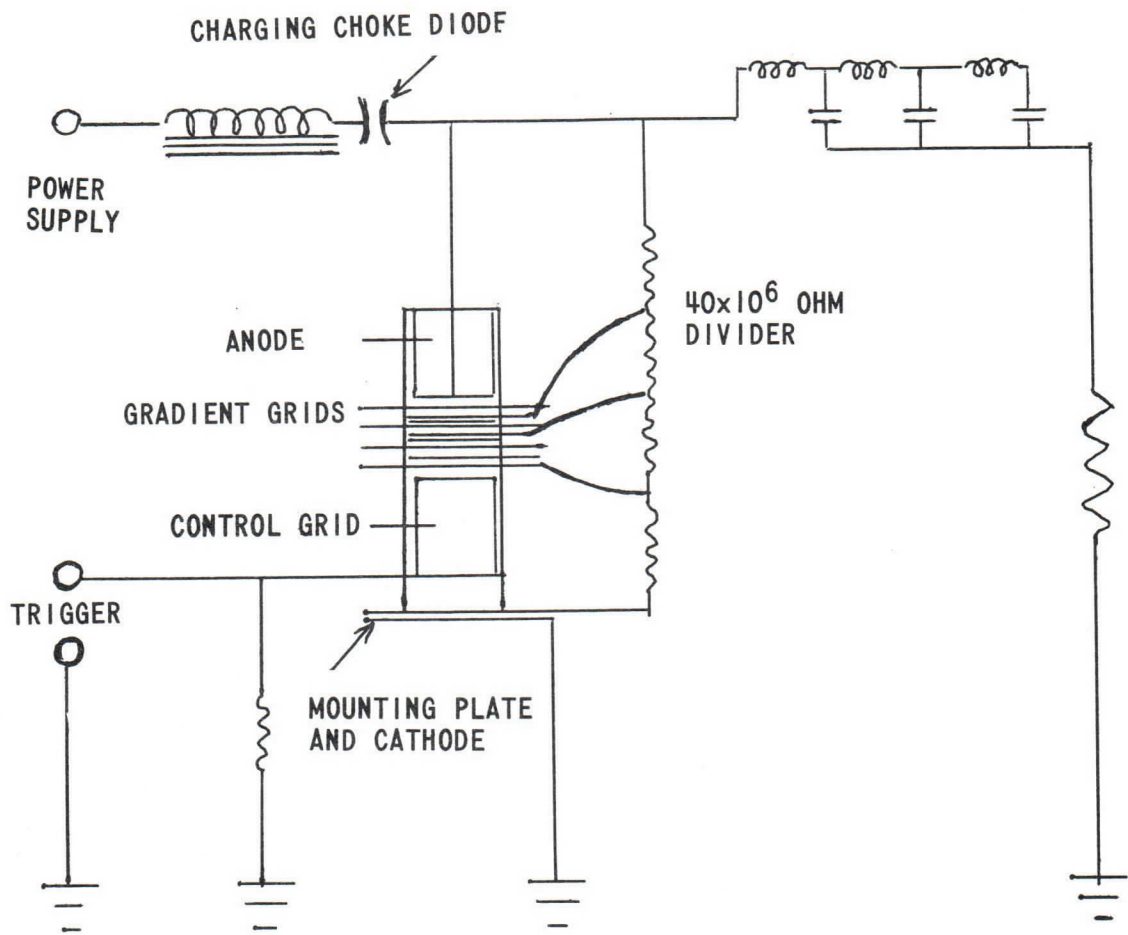

F-1087 OUTLINE
FIGURE 2