

2B33

Beam Power Tetrode

2B33 is a beam power tetrode having an indirectly heated unipotential cathode.

2B33 is used as a driver or a power amplifier of a transmitter up to a frequency of 60 MHz.

2B33 can also be used with triode connection, so that tube is suitable for an AF Power Amplifier or a Modulator.



Electrical Data:

General Data:

Cathode: Indirectly-Heated Oxide Coated Unipotential

	Min.	Bogie	Max.	Unit
Heater Voltage	5.7	6.3	6.9	V
Heater Current (at 6.3 volts)	-	0.9	-	A
Transconductance	-	6000	-	μS
(for $E_b=250Vdc$, $E_c2=250Vdc$ $E_{c1}=-14Vdc$)				
Direct Interelectrode Capacitances:				
Grid No. 1 to Plate (Note 1)	-	-	0.2	μpF
Input	-	10	-	μpF
Output	-	5.3	-	μpF
Frequency	-	-	60	MHz

Mechanical Data:

Dimensions:

Overall Length	123	128	133	mm
Maximum Diameter	-	-	39.7	mm
Net Weight (approx.)	-	60	-	gr.

Base:

Upper Part	JIS A9S
Bottom Part	JIS E19S-1

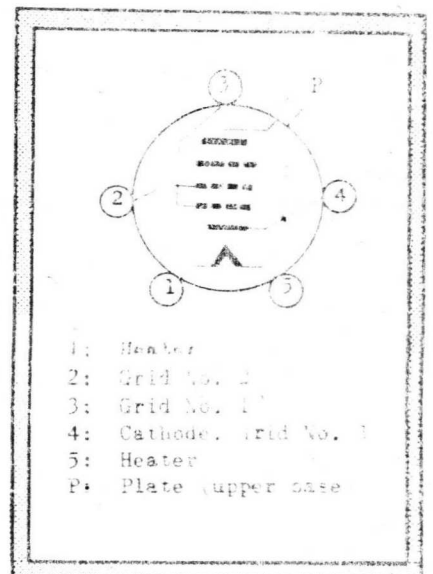

TERMINAL CONNECTIONS

2B33

Components:

Socket	JIS C 7006 Type Y
Cap	A9S
Mounting Position	any

Cooling: Natural Convection and Radiation (Note 2)

Note 1. "No. 312 shielded" (see EIAJ ET-21) is used.

Note 2. When used in a closed chamber, some means for forced-air cooling should be taken into account in order to prevent the stem temperature rise.

AF Power Amplifier and Modulator-Class AB1 (Note 3)

(Triode-connection, grid No. 2 is connected to plate)

Maximum Ratings:

DC Plate Voltage	400 Vdc
Max-Signal DC Plate Current (Note 4)	125 mA _{dc}
Max-Signal Plate Input (Note 4)	50 W
Plate Dissipation (Note 4)	25 W
Peak Heater to Cathode Voltage	<u>+135 V</u>

Typical Operation: : (Values are for 2 tubes)

DC Plate Voltage	400 Vdc
DC Grid No. 1 Voltage	-45 Vdc
Peak AF Grid No. 1 to Grid No. 1 Voltage	90 V
Zero-Signal DC Plate Current	64 mA _{dc}
Max-Signal DC Plate Current	140 mA _{dc}
Effective Load Resistance (Plate to Plate)	3000 Ω
Max-Signal Driving Power (approx.)	0 W
Max-Signal Plate Power Output (approx.)	15 W
Maximum Grid No. 1 Circuit Resistance:	
In case of fixed bias	100 k Ω
In case of cathode bias	500 k Ω

AF Power Amplifier and Modulator-Class AB1 (Note 3)

Maximum Ratings: Absolute Values:

DC Plate Voltage	600 Vdc
DC Grid No. 2 Voltage	300 Vdc
Max.-Signal DC Plate Current (Note 4)	120 mA _{dc}

Max.-Signal Plate Input (Note 4)	60 W
Max.-Signal Grid No. 2 Input (Note 4)	3.5 W
Plate Dissipation (Note 4)	25 W
Peak Heater to Cathode Voltage	± 135 V

Typical Operation: (Values are for 2 tubes)

DC Plate Voltage	400	500	600 Vdc
DC Grid No. 2 Voltage (Note 6)	300	300	300 Vdc
DC Grid No. 1 Voltage (Note 7)	-30	-32	-34 Vdc
Peak AF Grid No. 1 to Grid No. 1 Voltage	60	64	68 V
Zero-Signal DC Plate Current	50	44	36 mA _{dc}
Max-Signal DC Plate Current	143	141	139 mA _{dc}
Zero-Signal DC Grid No. 2 Current	2	1	0.6 mA _{dc}
Max-Signal DC Grid No. 2 Current	16	15	15 mA _{dc}
Effective Load Resistance (Plate to Plate)	6800	8200	10000 Ω
Max-Signal Driving Power (approx.)	0	0	0 W
Max-Signal Plate Power Output (approx.)	36	46	56 W
Grid No. 1 Circuit Resistance			
In case of fixed bias			100 k Ω
In case of cathode bias			Not recommended

AF Power Amplifier and Modulator-Class AB₂ (Note 5)

Maximum Ratings: Absolute Values

DC Plate Voltage	600 Vdc
DC Grid No. 2 Voltage	300 Vdc
Max-Signal DC Plate Current (Note 4)	120 mA _{dc}
Max-Signal Plate Input (Note 4)	60 W
Max-Signal Grid No. 2 Input (Note 4)	3.5 W
Plate Dissipation (Note 4)	25 W
Peak Heater to Cathode Voltage	± 135 V

Typical Operation: (Values are for 2 tubes)

DC Plate Voltage	400	500	600 Vdc
DC Grid No. 2 Voltage (Note 6)	300	300	300 Vdc
DC Grid No. 1 Voltage (Note 7)	-28	-30	-32 Vdc
Peak AF Grid No. 1 to Grid No. 1 Voltage	80	86	90 V
Zero-Signal DC Plate Current	72	60	48 mA _{dc}

2B33

Max-Signal DC Plate Current	240	240	200 mA _{dc}
Zero-Signal DC Grid No. 2 Current	2	0.9	0.7 mA _{dc}
Max-Signal DC Grid No. 2 Current	20	20	18 mA _{dc}
Effective Load Resistance (Plate to Plate)	3700	4600	6900 Ω
Max-Signal Driving Power (approx.)	0.2	0.2	0.1 W
Max-Signal Power Output (approx.)	55	75	80 W

Maximum Grid No. 1 Circuit Resistance:

In case of fixed bias	30 kΩ
In case of cathode bias	Not recommended

Note 3. A suffix "1" means that grid No. 1 current does not flow even at peak condition of maximum input signal. Maximum input signal voltage limit for the operating class of AB₁ will be reached when peak instantaneous grid No. 1 voltage becomes zero volts.

Note 4. Averaged over any audio-frequency cycle of sine-wave form.

Note 5. A suffix "2" means that grid No. 1 current will flow during some part of the input signal cycle.

Note 6. This voltage should be applied by a private source or by a voltage divider from the plate source.

Note 7. This voltage is delivered by a fixed bias.

RF Power Amplifier-Class B Telephony

(Carrier conditions per tube for use with a max. modulation factor of 1.0)

Maximum Ratings: Absolute Values

DC Plate Voltage	600 V _{dc}
DC Grid No. 2 Voltage	300 V _{dc}
DC Plate Current	80 mA _{dc}
Plate Input	37.5 W
Plate Dissipation	25 W
Grid No. 2 Dissipation	2.5 W
Peak Heater to Cathode Voltage	±135 V

Typical Operation: :

DC Plate Voltage	400	500	600 V _{dc}
DC Grid No. 2 Voltage	300	300	300 V _{dc}
DC Grid No. 1 Voltage (Note 8)	-40	-40	-40 V _{dc}
Peak RF Grid No. 1 Voltage	40	38	36 V
DC Plate Current	75	70	62.5 mA _{dc}

DC Grid No. 2 Current	5	4	4 mAde
DC Grid No. 1 Current (approx.)	9	0	0 mAde
Driving Power (approx.) (Note 9)	0.4	0.3	0.2 W
Plate Power Output (approx.)	9	11	12.5 W
Maximum Grid No. 1 Circuit Resistance			30 k Ω

Note 8. Fixed bias or capacitance by-passed cathode resistance bias should be used.

Note 9. Peak AF condition for use with a modulation factor of 1.0.

Plate Modulated RF Power Amplifier-Class C Telephony

(Carrier condition per tube for use with a max. modulation factor of 1.0)

Maximum Ratings: Absolute Values

DC Plate Voltage	475 Vdc
DC Grid No. 2 Voltage	300 Vdc
DC Grid No. 1 Voltage	-200 Vdc
DC Plate Current	83 mAde
DC Grid No. 1 Current	5 mAde
Plate Input	40 W
Plate Dissipation	16.5 W
Grid No. 2 Dissipation	2.5 W
Peak Heater to Cathode Voltage	± 135 V

Typical Operation: :

DC Plate Voltage	325	400	475 Vdc
DC Grid No. 2 Voltage (Note 10)	250	250	250 Vdc
In case of using series resistance	12.5	25	28 k Ω
DC Grid No. 1 Voltage (Note 11)	-75	-75	-85 Vdc
In case of using grid No. 1 resistance	21.4	21.4	21.2 k Ω
Peak RF Grid No. 1 Voltage	95	95	108 V
DC Plate Current	80	80	83 mAde
DC Grid No. 2 Current	6	6	8 mAde
DC Grid No. 1 Current (approx.)	3.5	3.5	4 mAde
Driving Power	0.3	0.3	0.4 W
Plate Power Output (approx.)	17	22	28 W
Maximum Grid No. 1 Circuit Resistance (Note 12)			30 k Ω

Note 10. This voltage should be applied from a private source modulated simultaneously with plate voltage, or from the plate source using

the series resistance shown above.

Note 11. This voltage should be applied by the grid No. 1 resistance shown above, by a combination of the grid No. 1 resistance and fixed bias or by a combination of the grid No. 1 resistance and cathode resistance.

Note 12. When grid No. 1 is driven positive, the total dc grid No. 1 circuit resistance should not exceed 30 kΩ. If this value is insufficient to provide adequate bias, the additional required bias must be supplied by a cathode resistor or fixed supply.

RF Power Amplifier -Class C Telegraphy and RF Power Amplifier-Class C FM Telephony

Maximum Ratings: Absolute Values

DC Plate Voltage	600 Vdc
DC Grid No. 2 Voltage	300 Vdc
DC Grid No. 1 Voltage	-200 Vdc
DC Plate Current	100 mA _{dc}
DC Grid No. 1 Current	5 mA _{dc}
Plate Input	60 W
Plate Dissipation	25 W
Grid No. 2 Dissipation	3.5 W
Peak Heater to Cathode Voltage	<u>+135 V</u>

Typical Operation :

DC Plate Voltage	400	500	600 Vdc
DC Grid No. 2 Voltage	250	250	250 Vdc
In case of using series resistance	19	31	44 kΩ
DC Grid No. 1 Voltage	-45	-45	-45 Vdc
In case of using grid No. 1 resistance	11.2	11.2	11.2 kΩ
In case of using cathode resistance	400	400	400 Ω
Peak RF Grid No. 1 Voltage	65	65	65 Vdc
DC Plate Current	100	100	100 mA _{dc}
DC Grid No. 2 Current	8	8	8 mA _{dc}
DC Grid No. 1 Current	4	4	4 mA _{dc}
Driving Power (approx.)	0.3	0.3	0.3 W

2B33

Plate Power Output (approx.)	25	32	40 W
Load Power Output (approx.)	22	28	36 W
Maximum Grid No. 1 Circuit Resistance			30 k Ω

AVERAGE CHARACTERISTICS
(TRIODE CONNECTIONS)

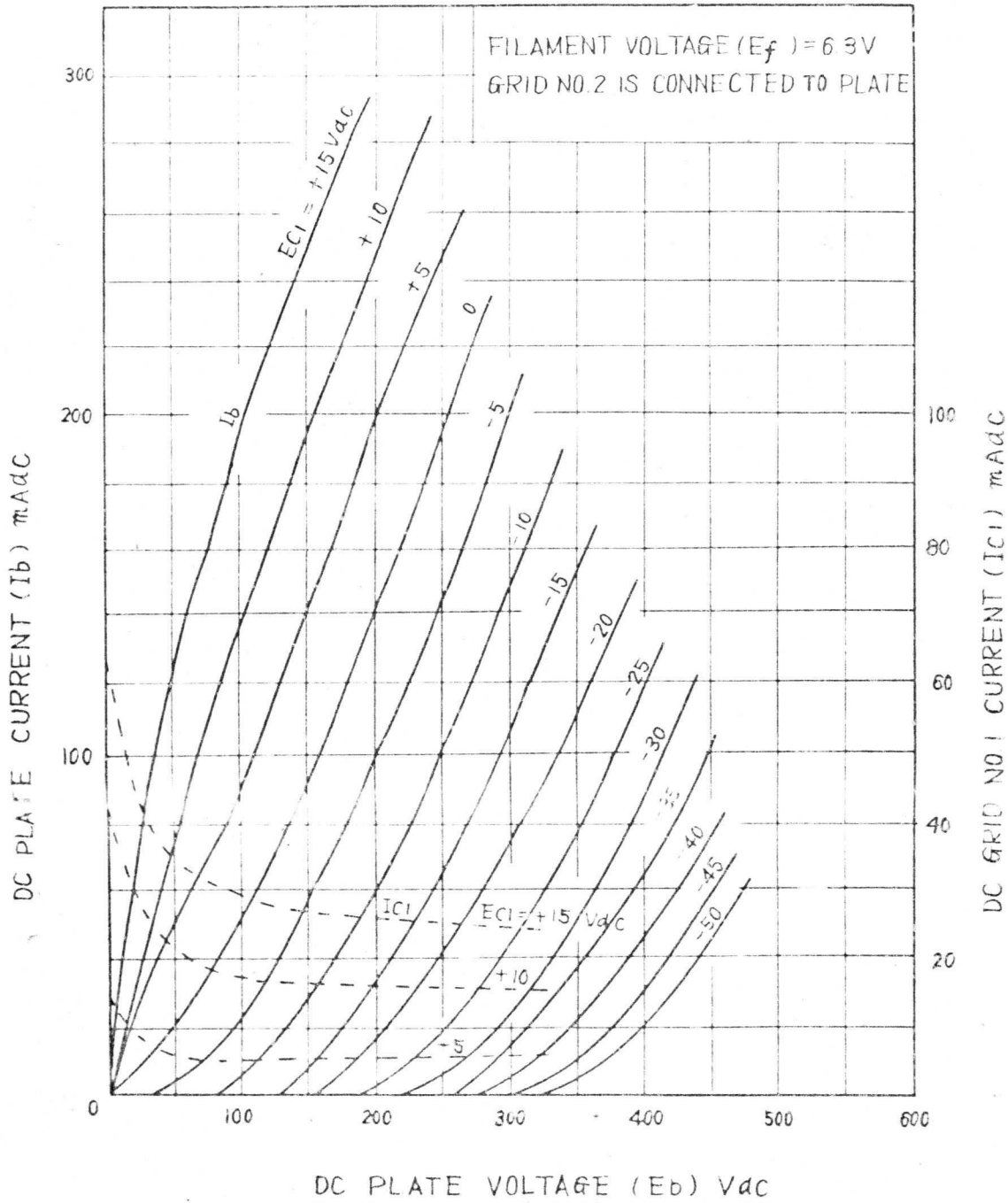

CONSTANT CURRENT CHARACTERISTICS

$E_{c2} = 250\text{Vdc}$ $E_f = 6.3\text{V}$

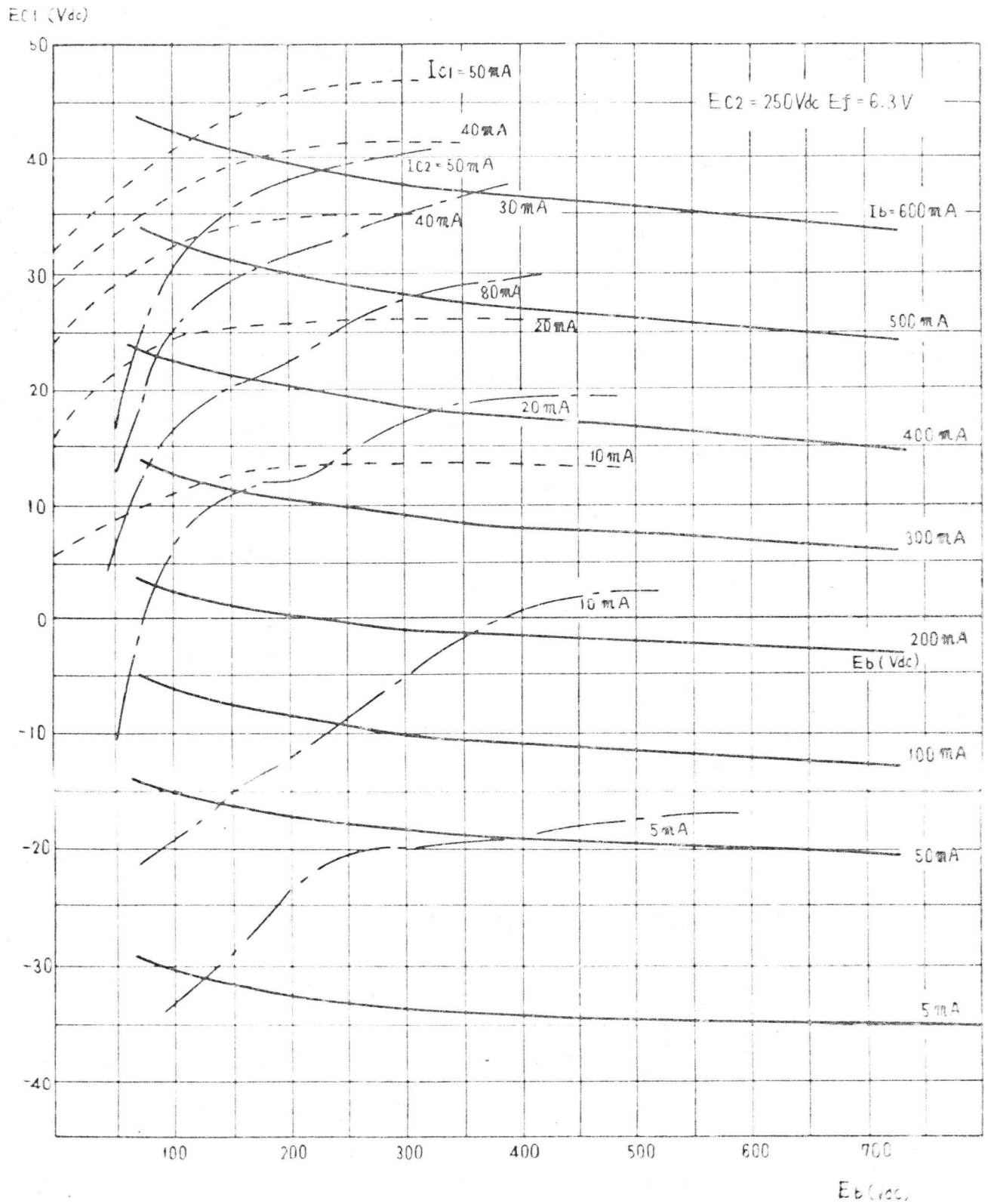

CONSTANT CURRENT CHARACTERISTICS

$E_{c2} = 300 \text{ Vdc}$ $E_f = 6.3 \text{ V}$

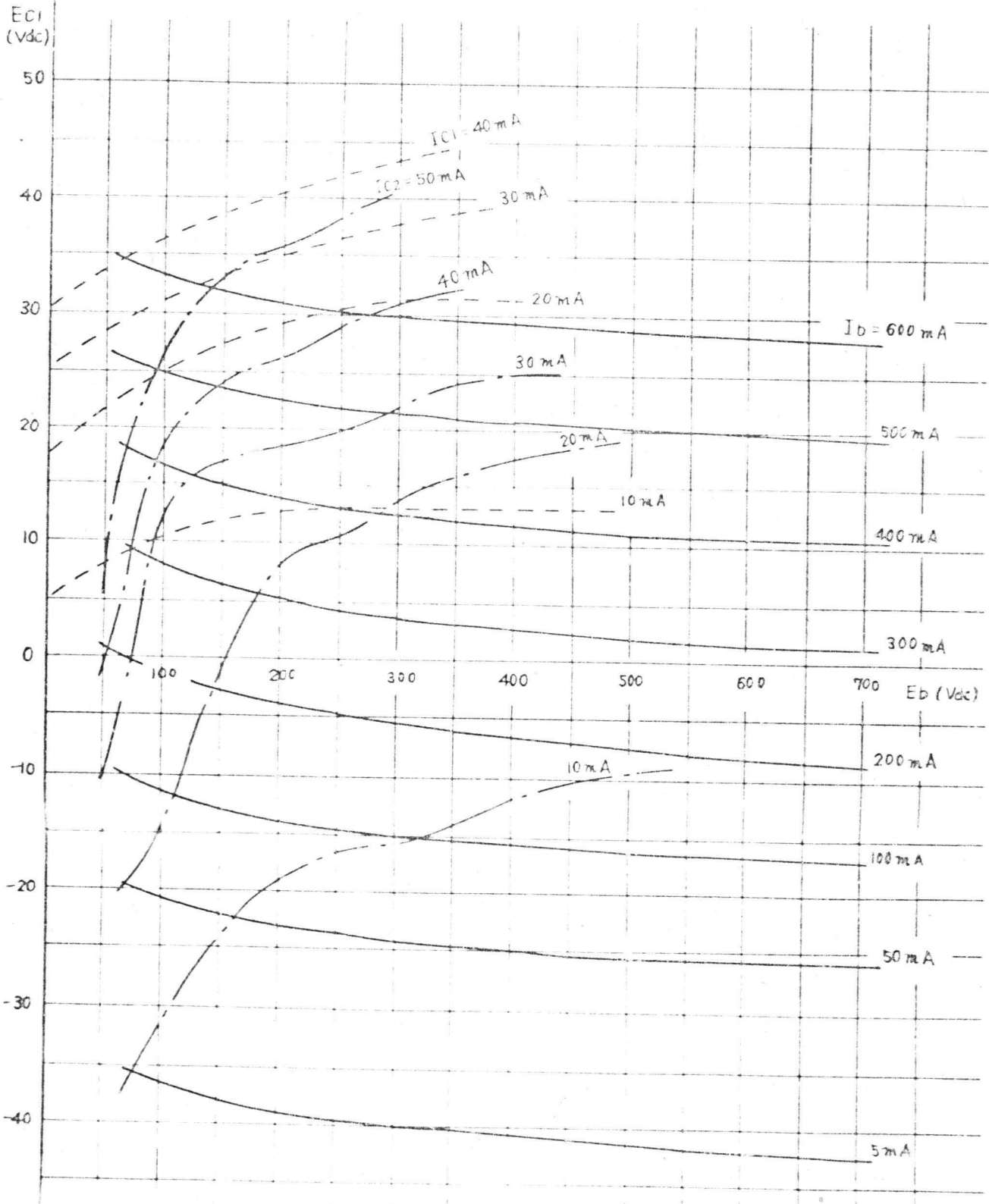

OUTLINE DRAWING

Unit mm

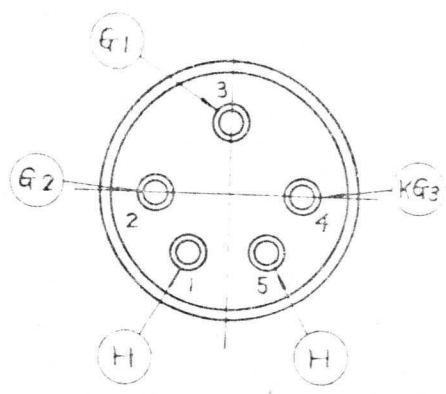
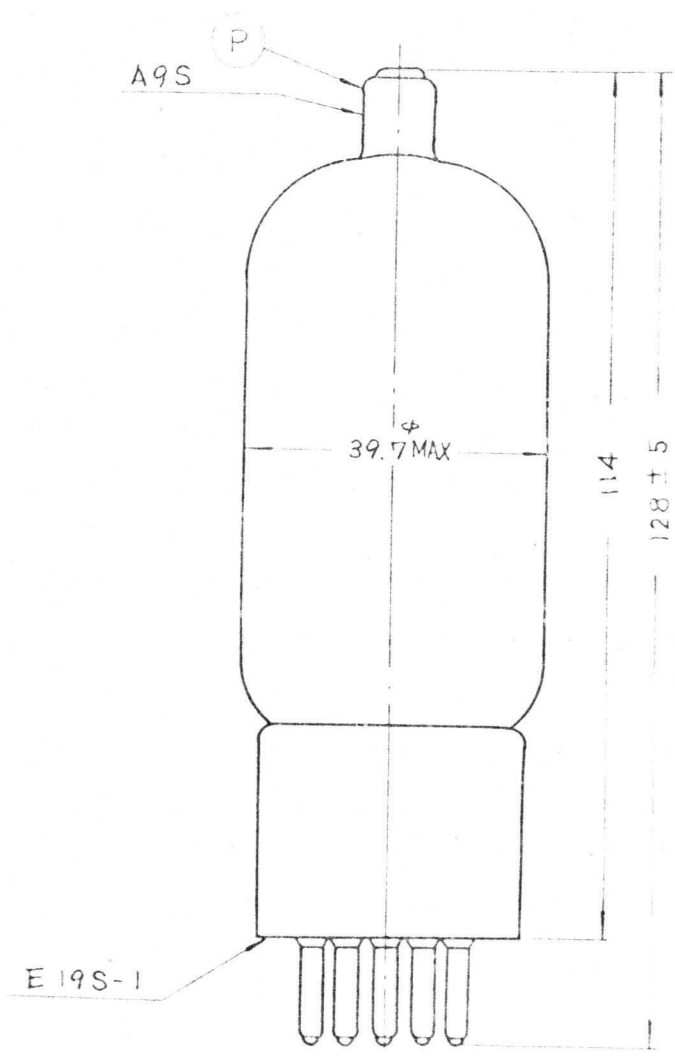

2K25

SHF REFLEX KLYSTRON

The type 2K25 is a reflex klystron operating over a frequency range of 8,500 to 9,660 Mc and delivering a power output of 20 mW (min.) at 9,370 Mc, 300 Volts on resonator.

STRUCTURAL FEATURES

Integral cavity and full-range tuner, coaxial output line through base of tube designed for use with broad-band waveguide starting section.

GENERAL CHARACTERISTICS

Frequency Range8,500 to 9,660 Mc
 Cathode Oxide-coated, indirectly heated
 Heater Voltage 6.3 Volts
 Heater Current 0.44 Amperes

MECHANICAL FEATURES

Resonant Cavity Integral part of the tube
 Envelope Metal
 Base Small wafer, octal, 4 pins and coaxial output terminal
 Weight 45 g

MAXIMUM RATINGS

Resonator Voltage 330 Volts
 Resonator Current 37 Milliampers
 Heater Voltage 5.8~6.8 Volts
 Heater to Cathode Voltage ± 50 Volts
 Reflector Voltage 0 to -400 Volts

TYPICAL OPERATING DATA

Frequency9,370Mc
 Resonator Voltage 300 Volts
 Resonator Current 25 Milliampers
 Reflector Voltage -130 to -180 Volts
 Reflector Current Less than 1 Microampere
 Electronic Tuning Range 40 Mc
 Power Output 35 Milliwatts

NOTICE

1. The heater voltage must be applied one minute before resonator voltage is applied.
2. The reflector voltage must always be applied before resonator voltage.
3. The reflector must never become positive with respect to the cathode.

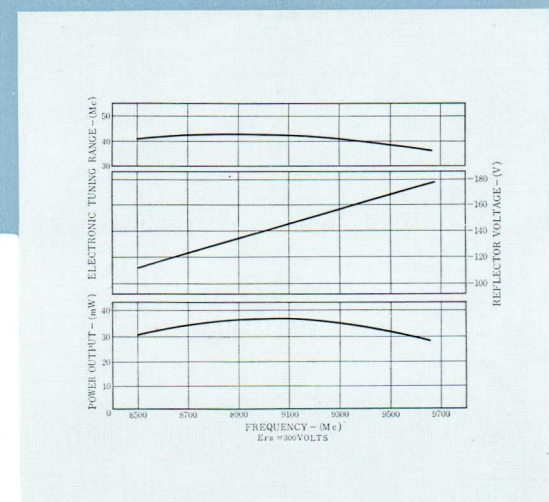
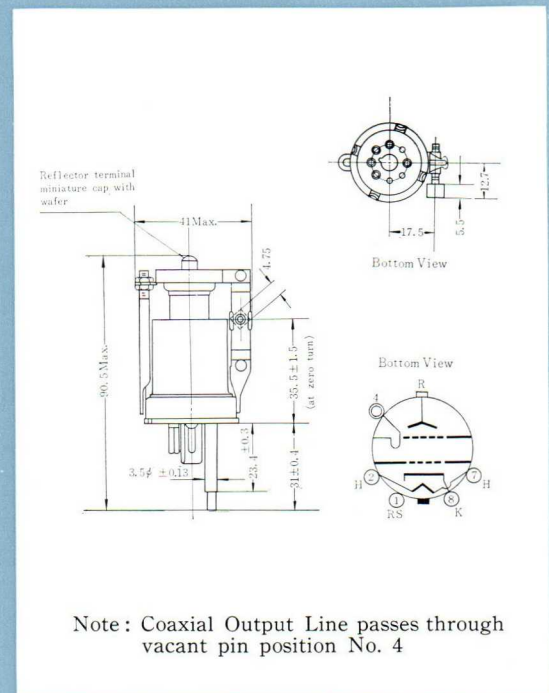

2K26

SHF REFLEX KLYSTRON

The type 2K26 is a reflex klystron operating over a frequency range of 6,250 to 7,060 Mc and delivering a power output of 80 mW (min.) at 6,660 Mc, 300 Volts on resonator.

STRUCTURAL FEATURES

Integral cavity and full-range tuner; coaxial output line through base of tube designed for use with broad-band waveguide starting section.

GENERAL CHARACTERISTICS

Frequency Range..... 6,250 to 7,060 Mc
 Cathode Oxide-coated, indirectly heated
 Heater Voltage..... 6.3 Volts
 Heater Current..... 0.44 Amperes

MECHANICAL FEATURES

Resonant Cavity Integral part of the tube
 Envelope Metal
 Base Small wafer, octal, 4 pins
 and coaxial output terminal
 Weight 45 g

MAXIMUM RATINGS

Resonator Voltage 330 Volts
 Resonator Current 35 Milliampers
 Heater Voltage 5.8 to 6.8 Volt
 Heater to Cathode Voltage ± 50 Volts
 Reflector Voltage 0 to -350 Volts

TYPICAL OPERATING DATA

Frequency 6,660 Mc
 Resonator Voltage 300 Volts
 Resonator Current 25 Milliampers
 Reflector Voltage -70 to -115 Volts
 Reflector Current Less than 1 Microampere
 Electronic Tuning Range 50 Mc
 Power Output 100 Milliwatts

NOTICE

1. The heater voltage must be applied one minute before resonator voltage is applied.
2. The reflector voltage must always be applied before the resonator voltage.
3. The reflector must never become positive with respect to the cathode.

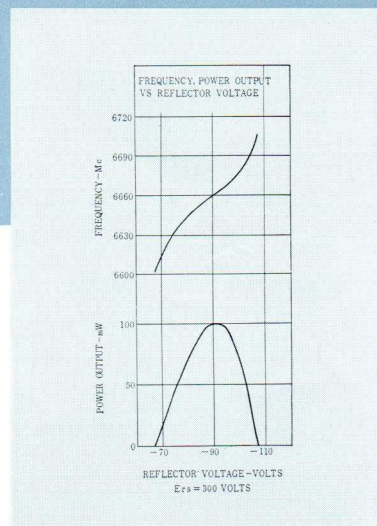
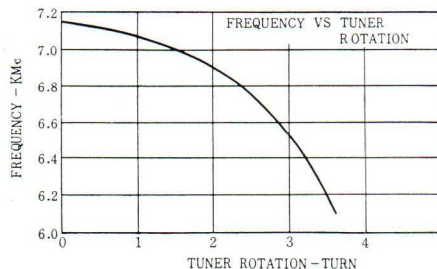
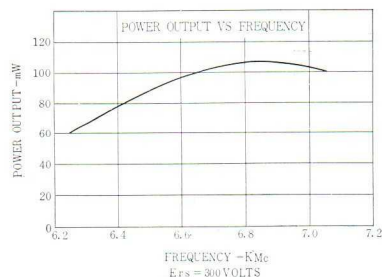
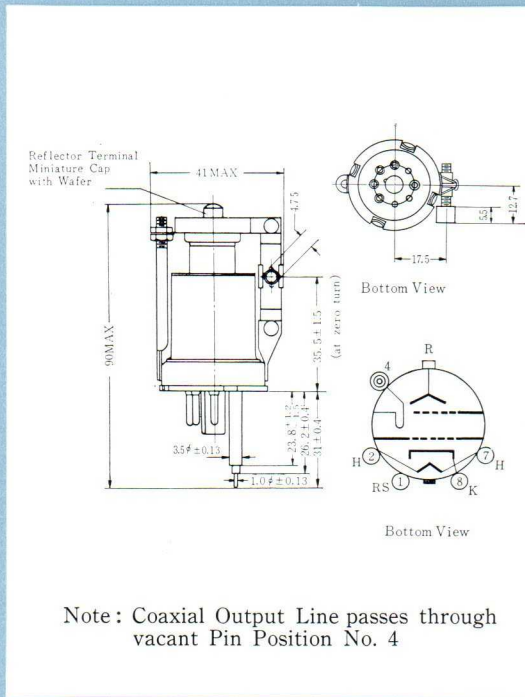

Nippon Electric Company Ltd.

2, Shiba Mita Shikoku-machi, Minato-ku, Tokyo, Japan
 Tel. Tokyo 45-1171 (9) • 5121 (9) • 5221 (9)
 Cable Address "MICROPHONE TOKYO"

4B38

AIR COOLED BEAM POWER TUBE

ELECTRICAL DATA;

GENERAL DATA;

Cathode; Indirectly Heated Oxide Coated

Heater Voltage ----- 6.3 Volts

Heater Current ----- 4.8 Amps

Warming up Time ----- 60 Sec

Amplification Factor Grid No.2

to Grid No.1 ----- 6

Direct Interelectrode Capacitances,

Grid No.1 to Plate ----- 1.5 μ F

Input ----- 50 μ F

Output ----- 20 μ F

Heater to Cathode ----- 25 μ F

Transconductance ----- 20 millimhos

(for $I_b=300\text{mA dc}$; $E_b=500\text{V dc}$; $E_{c2}=200\text{V dc}$)

Maximum Frequency for Maximum Ratings - 10MHz/s

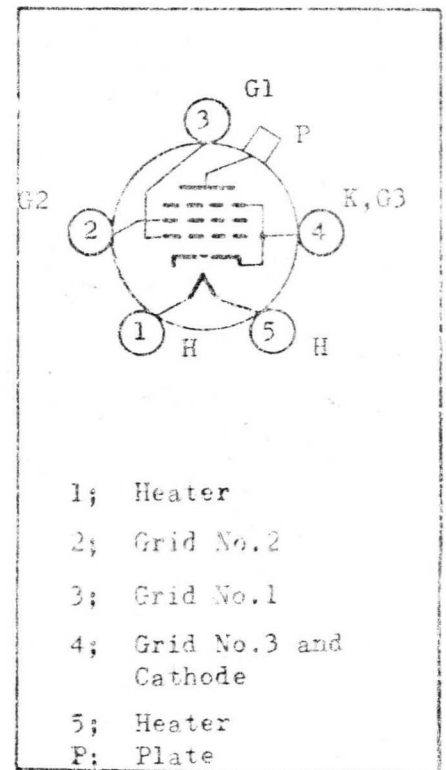
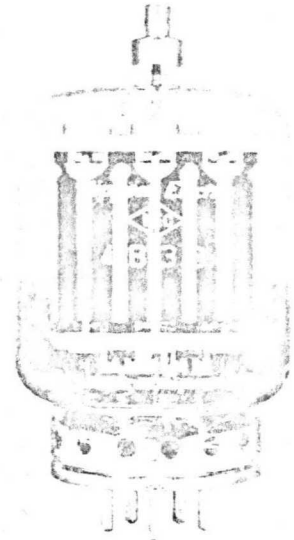

MECHANICAL DATA;

Base;

Upper Part ----- A93

Bottom Part ----- E32S-2

Cooling; Natural Convection and Radiation,
or Forced Air Cooling

Maximum Bulb Temperature ----- 175°C

Mounting Position; Vertical, bottom base down or up

Dimensions;

TERMINAL CONNECTIONS

NEC
Nippon Electric Co., Ltd.

Overall Length	-----	175-6mm
Maximum Diameter	-----	93 mm
Net weight	-----	370 gr (approx.)

AF POWER AMPLIFIER AND MODULATOR--CLASS AB1

MAXIMUM RATINGS;

DC Plate Voltage	-----	1250 Volts
DC Grid No.2 Voltage	-----	400 Volts
Max. Signal DC Plate Current*	-----	600 mA
Max. Signal Plate Input*	-----	450 Watts
Plate Dissipation	-----	150 Watts
Peak Heater to Cathode Voltage	-----	<u>±</u> 500 Volts

Note; When fixed bias is used, grid No.1 circuit resistance should be the value of 50KΩ or less.

TYPICAL OPERATION; (Values are for two tubes)

DC Plate Voltage	-----	800	1000 Volts
DC Grid No.2 Voltage	-----	300	300 Volts
DC Grid No.1 Voltage	-----	-50	-50 Volts
Peak AF Grid No.1 to Grid No.1 Voltage	-----	100	100 Volts
Max. Signal DC Plate Current	-----	800	720 mA
Zero-Signal DC Plate Current	-----	100	80 mA
Max. Signal DC Grid No.2 Current	-----	80	70 mA
Effective Load Resistance (Plate to Plate)	-----	1900	2800 Ohms
Plate Power Output (approx.)	-----	380	450 Watts

CATHODE FOLLOWER AMPLIFIER; (Values are for two tubes)

DC Plate Voltage	-----	800	1000 Volts
------------------	-------	-----	------------

DC Grid No.2 Voltage	-----	300	300 Volts
DC Grid No.1 Voltage	-----	-50	-50 Volts
Peak AF Grid No.1 to Grid No.1 Voltage	-----	1200	1600 Volts
Max. Signal DC Plate Current**	-----	800	720 mA
Max. Signal Peak Plate Current	-----	1.3	1.2 Amps
Zero-Signal DC Plate Current	-----	100	80 mA
Max. Signal DC Grid No.2 Current**	-----	80	70 mA
Peak AF Cathode to Cathode Voltage	-----	1200	1600 Volts
Plate Power Output (approx.)	-----	380	450 Watts

Note; Peak Cathode to Grid No.1 Voltage should never exceed +300 Volts.

* Average value over any audio-frequency-cycle of sine wave form.

** Value of pure resistance load.

PLATE CHARACTERISTICS (1)

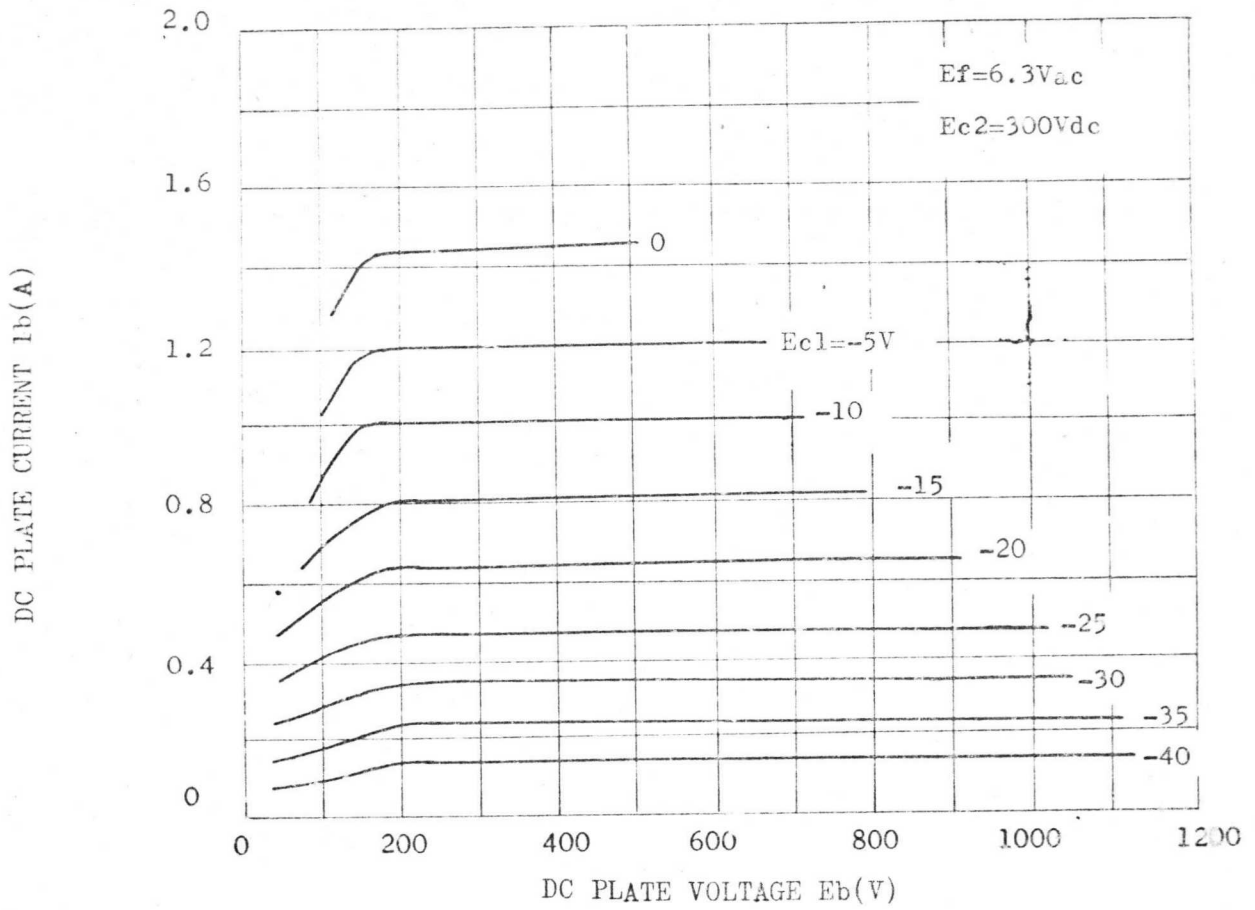
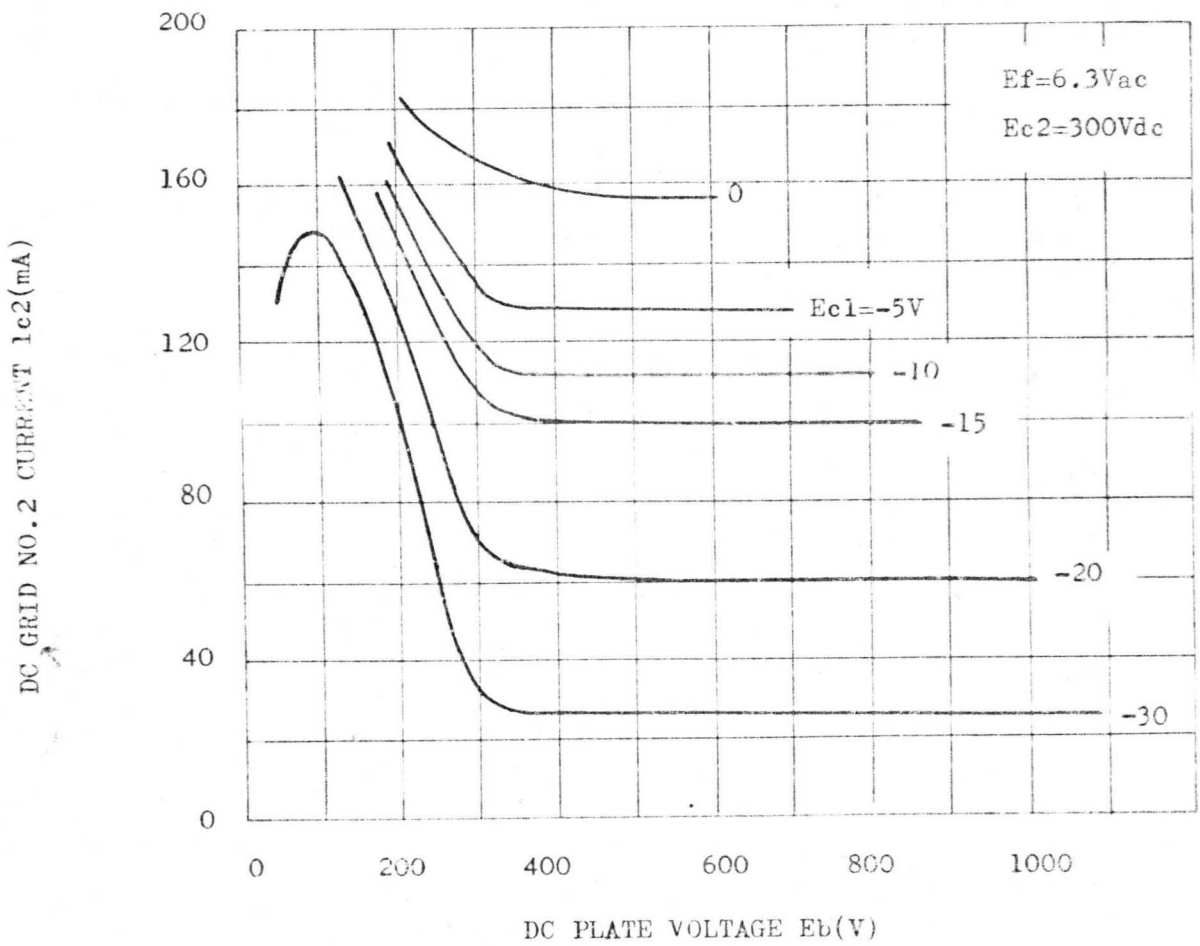
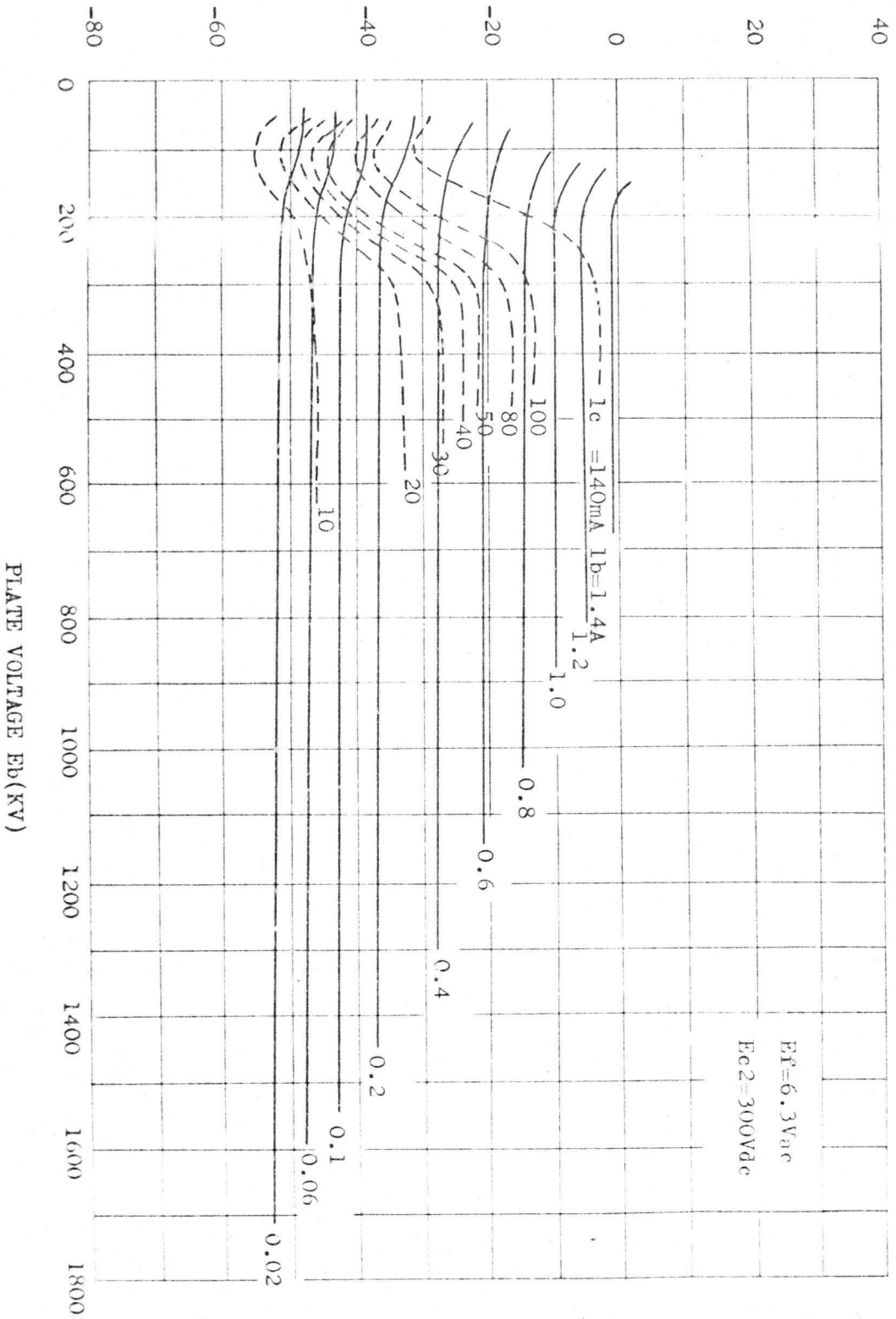

PLATE CHARACTERISTICS (2)



GRID NO.1 VOLTAGE $E_{c1}(V)$

CONSTANT CURRENT CHARACTERISTICS



OUTLINE DRAWING

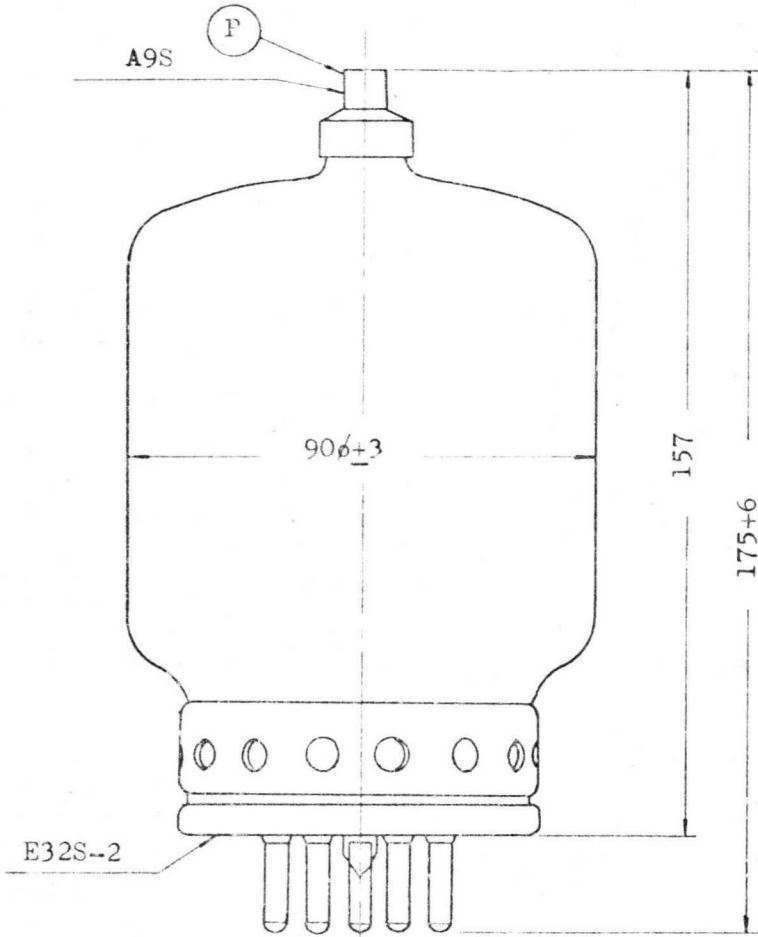

(Unit: mm)

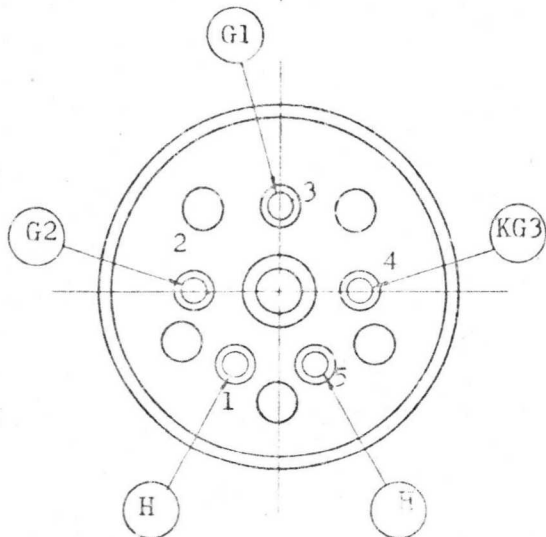
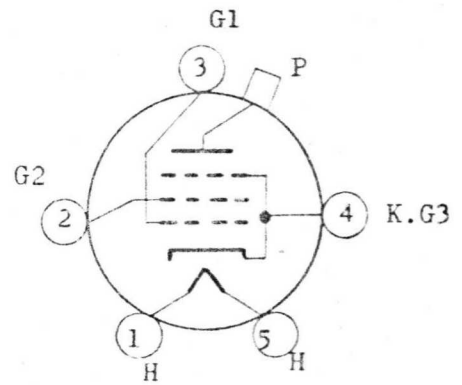

4P55

Natural Air Cooled Pentode

NEC

The NEC 4P55 is a natural air cooled pentode designed for use as a RF power amplifier, grid No. 3 modulated amplifier and AF power amplifier or modulator. The anode is capable of dissipating 120 watts and the cathode is an oxide coated unipotential type. Maximum ratings apply up to 25 megacycles.

Electrical Data :

General Data :

Cathode: Oxide Coated Unipotential

Voltage	6.3 V
Current	2.6 A
Minimum Heating Time	60 sec.
Amplification Factor, Grid No. 2 to Grid No. 1	5.5
Transconductance (I _b =100mA)	6.5 m _g

Direct Interelectrode Capacitances:

Grid to Plate	0.4 pF
Input	25 pF
Output	21 pF

Mechanical Data :

Mounting Position: Vertical, base down or up

Dimensions:

Maximum Diameter	78 mm
Maximum Overall Length	166 mm
Cap. plate and grid No. 3	Medium, A14S
Base	A5-97, E32S

Cooling: Natural

Maximum seal temperature (Cap)	180°C
Net Weight	300 g

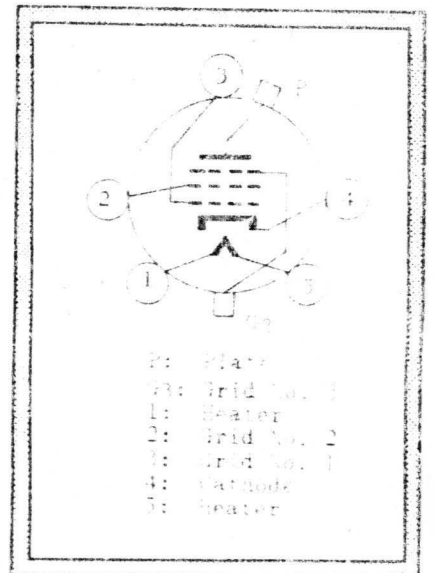
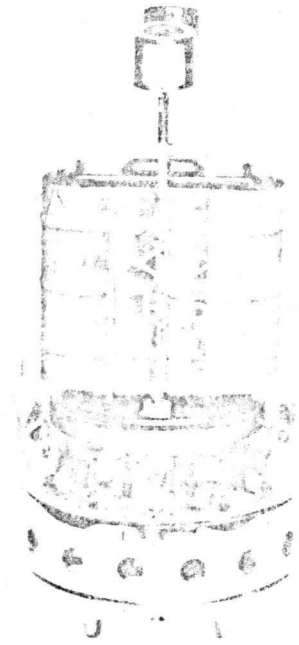

TERMINAL CONNECTIONS

OUT LINE DRAWING

UNIT: mm

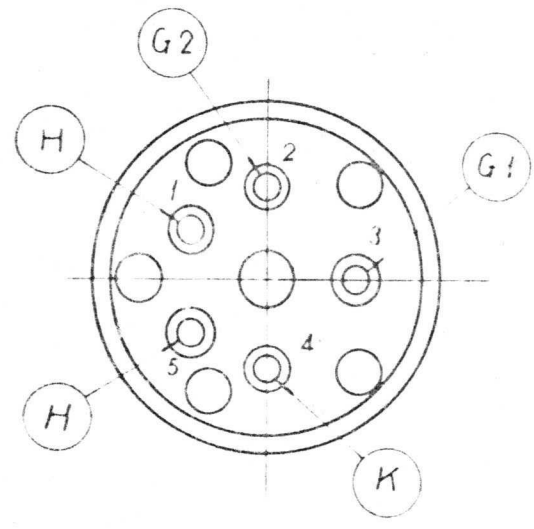
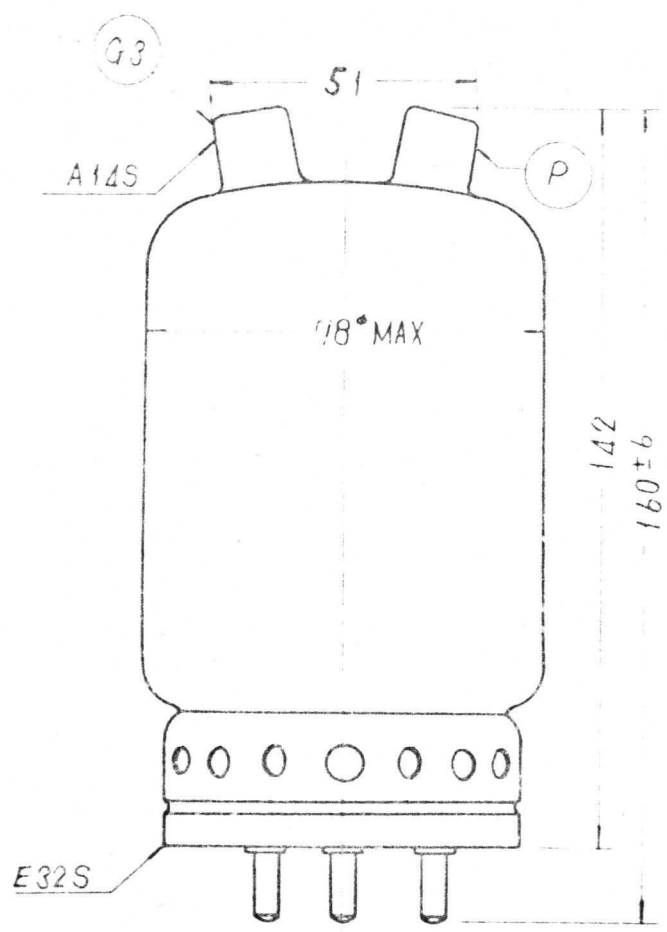

Grid No. 2 Dissipation	15 watts
Peak Heater-Cathode Voltage:	
Heater negative with respect to cathode	200 volts
Heater positive with respect to cathode	200 volts

Typical Operation :

DC Plate Voltage	1000	1250	1250 volts
DC Grid No. 3 Voltage	0	0	0 volts
DC Grid No. 2 Voltage	300	300	300 volts
DC Grid No. 1 Voltage (note 2)	-55	-60	-60 volts
Peak RF Grid No. 1 Voltage (note 2)	55	60	75 volts
DC Plate Current	140	140	200 mA
DC Grid No. 2 Current	10	10	18 mA
DC Grid No. 1 Current approx.	-	-	1 mA
Driving Power approx.	-	-	0.1 watts
Power Output approx.	80	110	150 watts

Note 2. Grid No. 1 to Cathode peak voltage should not exceed $\pm 300V$.

Grid No.3-Modulated RF Power Amplifier-Class C Telephony

(Carrier conditions per tube for use with a maximum modulation factor of 1.0)

Maximum Ratings : Absolute Values

DC Plate Voltage	1500 volts
DC Grid No. 2 Voltage	400 volts
DC Grid No. 1 Voltage	-300 volts
DC Plate Current	130 mA
DC Grid No. 2 Current	40 mA
DC Grid No. 1 Current	10 mA
Plate Input	150 watts
Plate Dissipation	15 watts
Peak Heater-Cathode Voltage:	
Heater negative with respect to cathode	200 volts
Heater positive with respect to cathode	200 volts

Typical Operation :

DC Plate Voltage	1250	1250 volts
DC Grid No. 3 Voltage	-100	-100 volts
Grid No. 2 Series Resistor (note 3)	45	4.5 k Ω

CONSTANT CURRENT CHARACTERISTICS

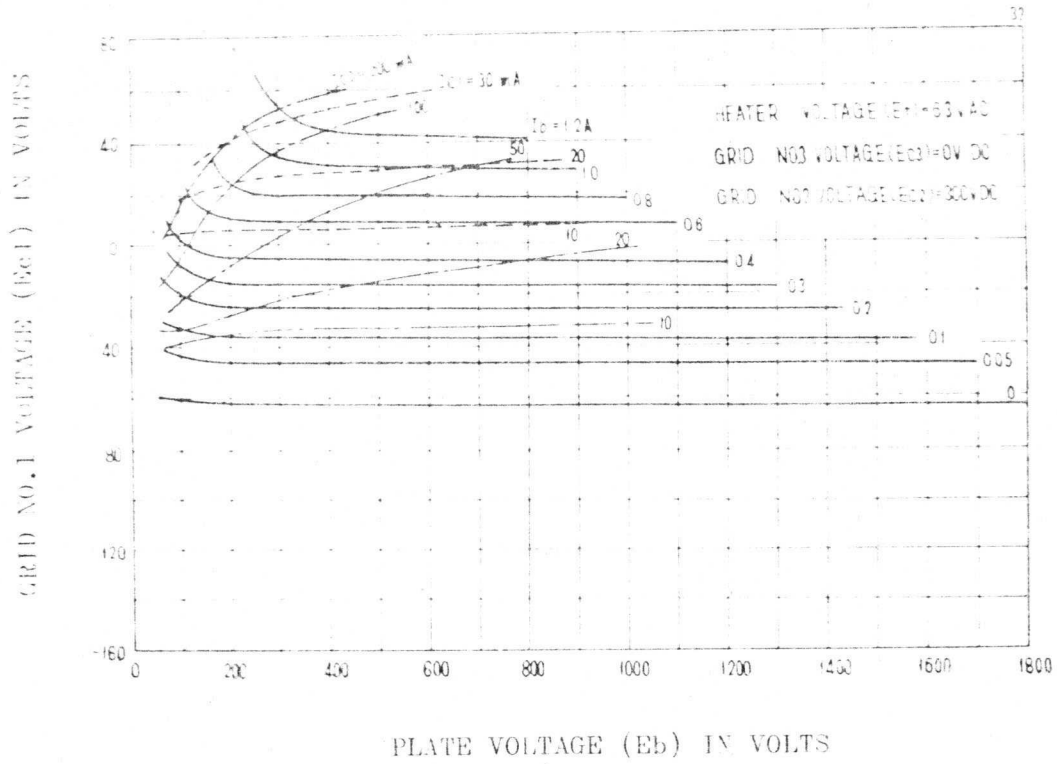

CONSTANT CURRENT CHARACTERISTICS

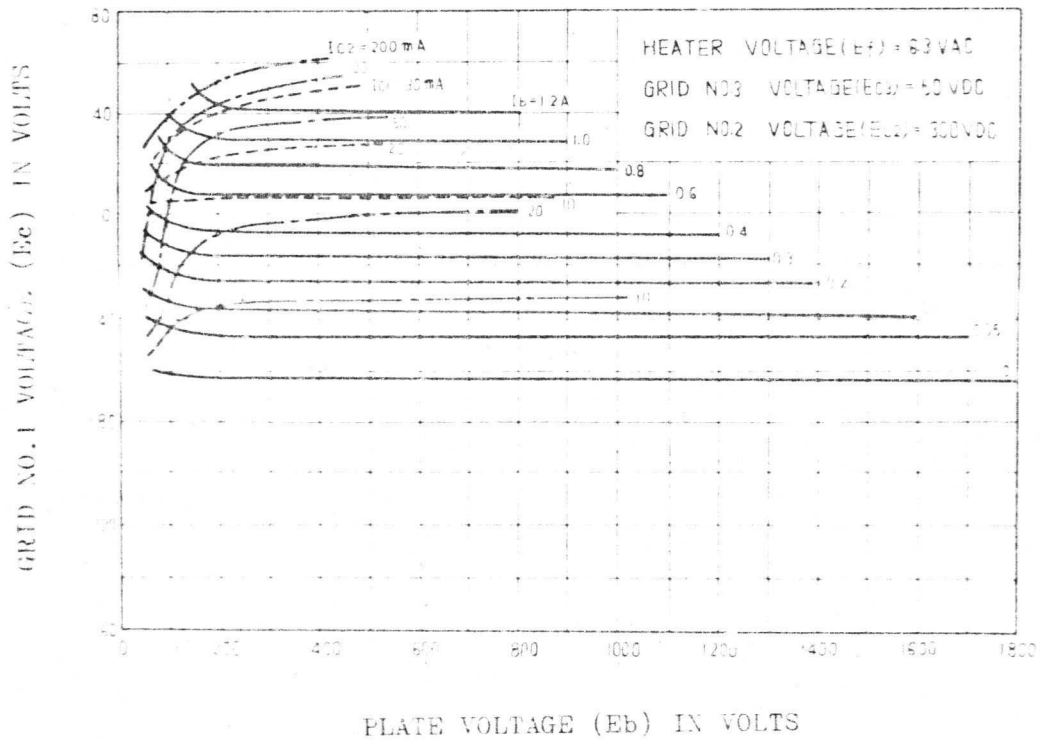

4P55

DC Grid No. 1 Voltage	-120	-120 volts
Peak AF Grid No. 3 Voltage	150	160 volts
Peak RF Grid No. 1 Voltage	145	145 volts
DC Plate Current	110	110 mA
DC Grid No. 2 Current	22	22 mA
DC Grid No. 1 Current, approx.	3	3 mA
Driving Power approx.	0.45	0.45 watts
Power Output approx.	55	55 watts

Note 3. 45 k Ω from unmodulated plate-voltage supply and 4.5 k Ω from fixed supply of 40 V.

Radio-Frequency Power Amplifier and Oscillator-Class C Telegraphy

Radio-Frequency Power Amplifier and Oscillator - Class C Telegraphy

(Key-down conditions per tube without amplitude modulation)

Maximum Ratings: Absolute Values

DC Plate Voltage	1500 volts
DC Grid No. 3 Voltage	100 volts
DC Grid No. 2 Voltage	400 volts
DC Grid No. 1 Voltage	-300 volts
DC Plate Current	250 mA
DC Grid No. 2 Current	40 mA
DC Grid No. 1 Current	10 mA
Plate Input	300 watts
Plate Dissipation	120 watts
Grid No. 2 Dissipation	15 watts
Grid No. 1 Dissipation	5 watts
Peak Heater-Cathode Voltage:	
Heater negative with respect to cathode	250 volts
Heater positive with respect to cathode	200 volts

Typical Operation:

DC Plate Voltage	1000	1250	1250 volts
DC Grid No. 3 Voltage	0	0	50 volts
DC Grid No. 2 Voltage	200	300	300 volts
DC Grid No. 1 Voltage	-80	-120	-120 volts
Peak RF Grid No. 1 Voltage	110	145	145 volts
DC Plate Current	180	200	200 mA
DC Grid No. 2 Current	25	25	20 mA

DC Grid No. 1 Current approx.	3	2	2 mA
Grid No. 1 Power approx.	0.3	0.3	0.3 watts
Tower Output approx.	125	170	180 watts

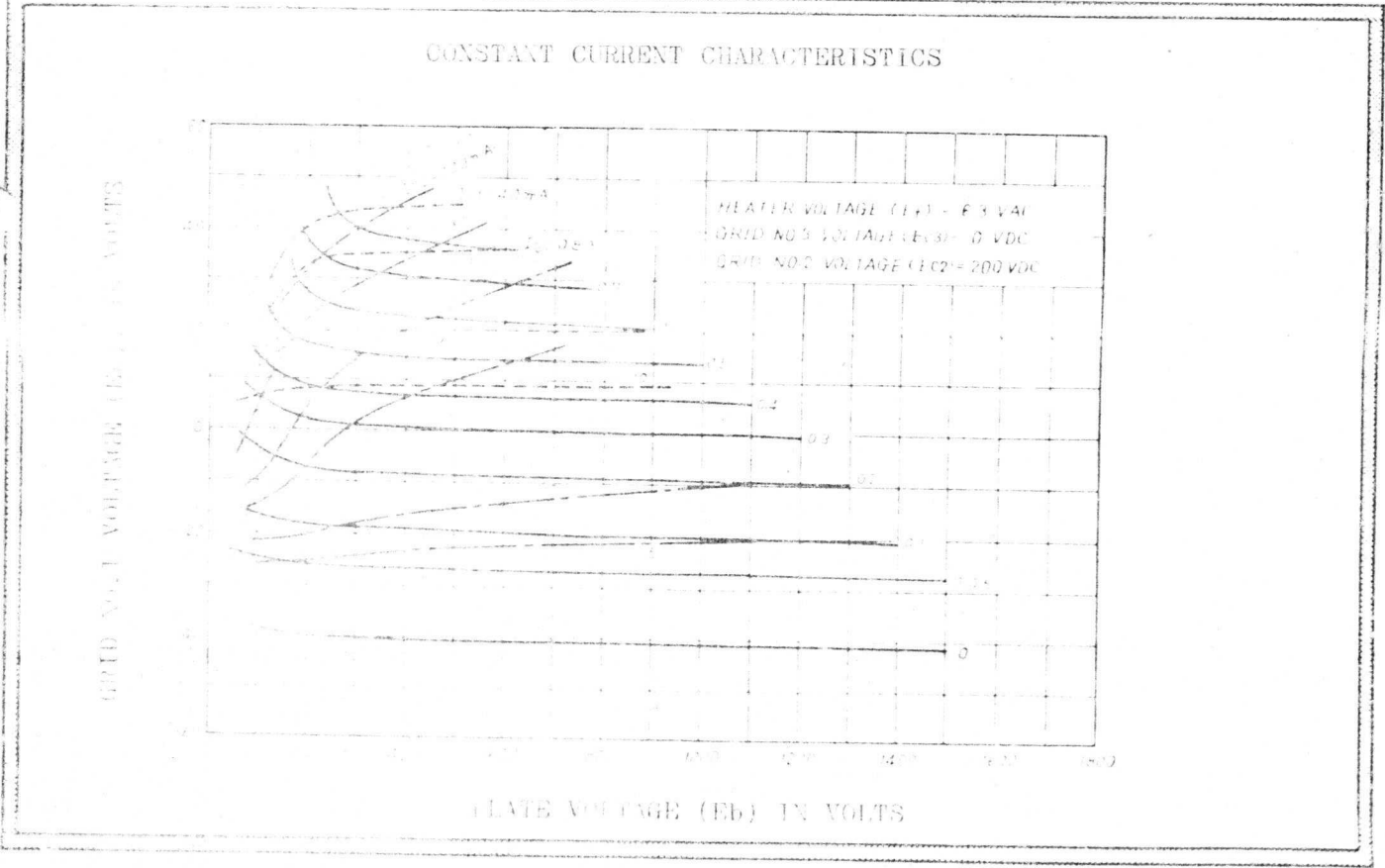
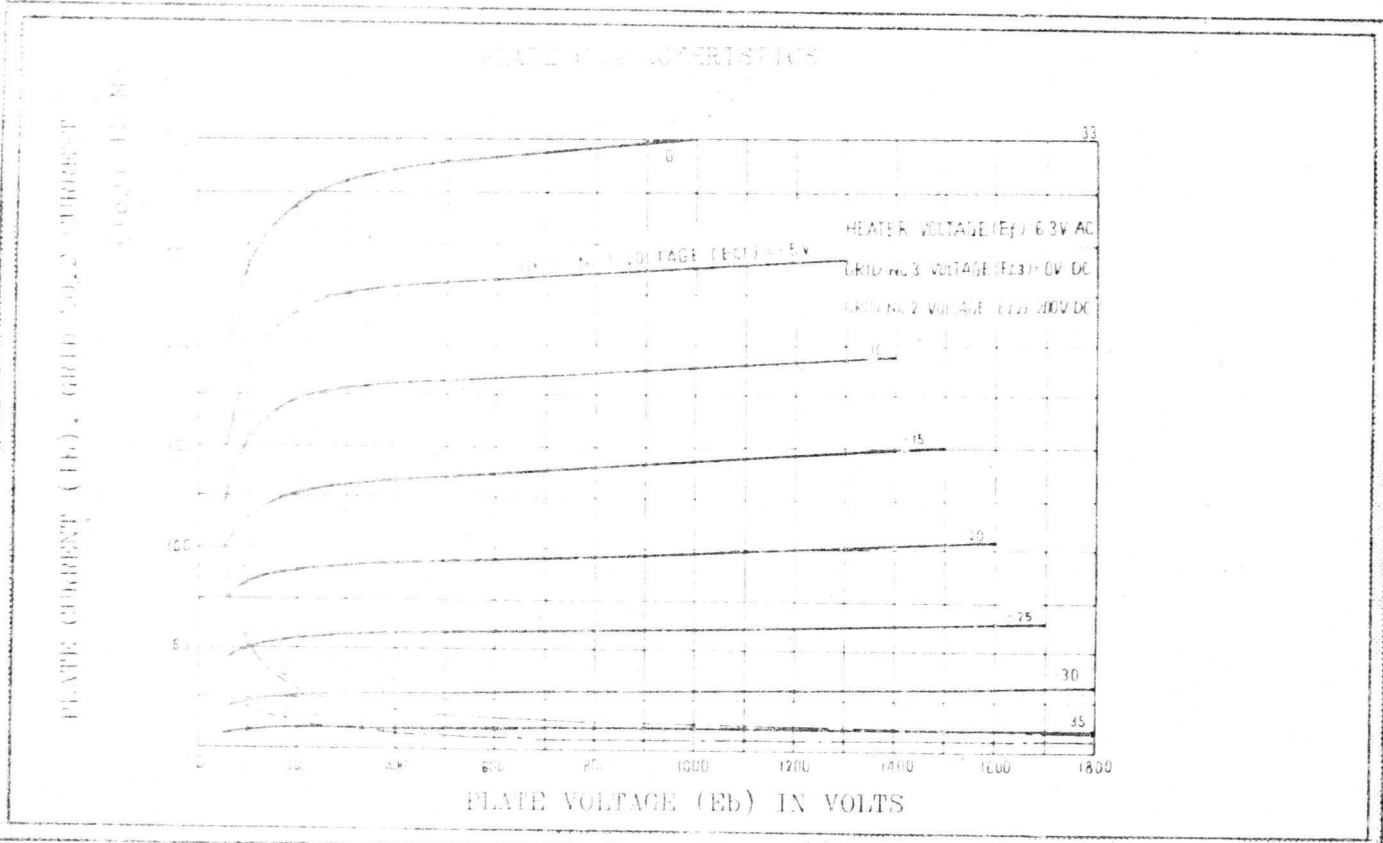

CONSTANT CURRENT CHARACTERISTICS

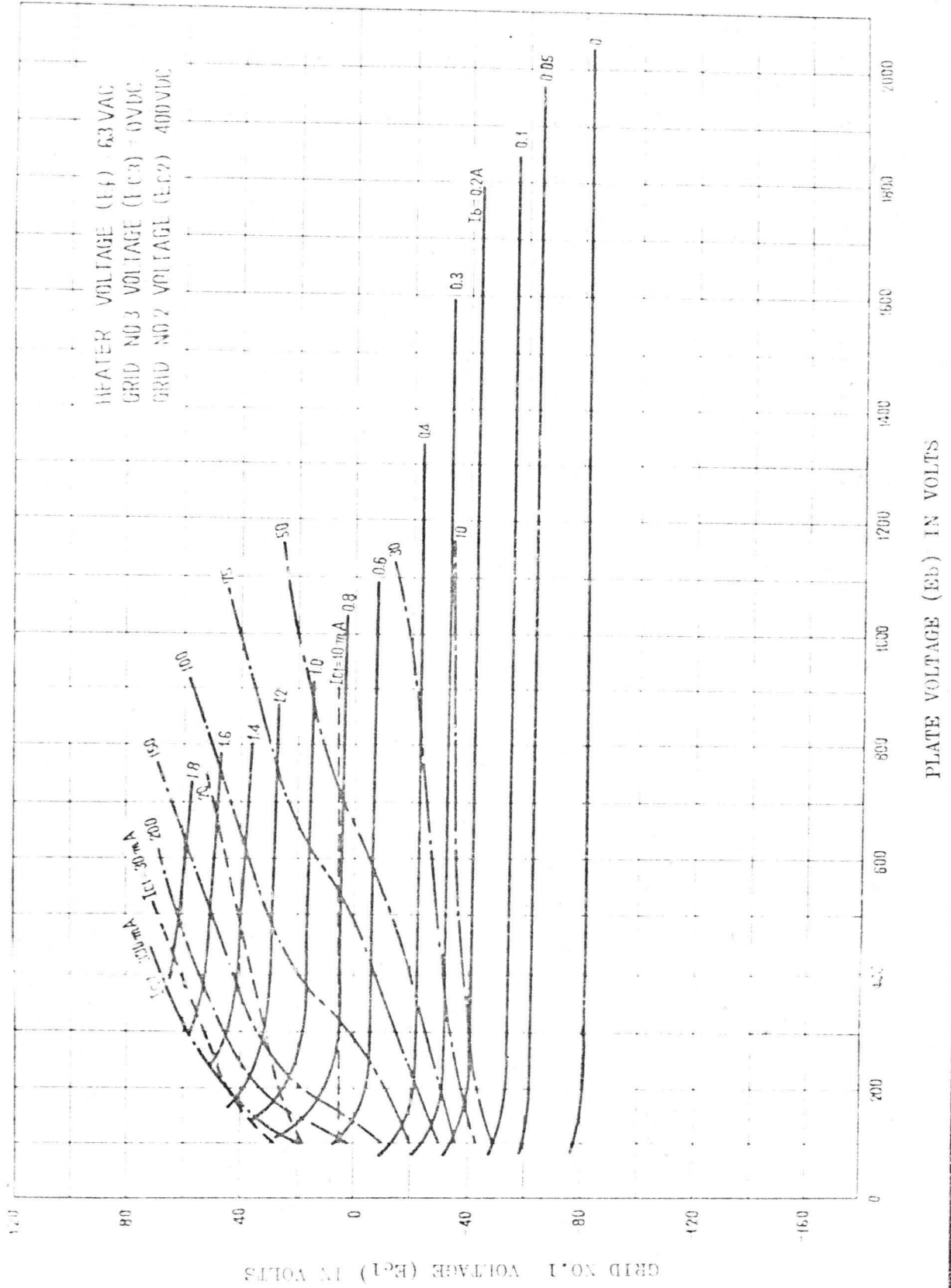

AF Power Amplifier and Modulator-Class AB

Maximum Ratings : Absolute Values

DC Plate Voltage	1500 volts
DC Grid No. 3 Voltage	100 volts
DC Grid No. 2 Voltage	400 volts
Maximum Signal DC Plate Current (note 1)	200 mA
Maximum Signal Plate Input (note 1)	300 watts
Plate Dissipation (note 1)	120 watts
Grid No. 2-Dissipation (note 1)	15 watts
Peak Heater-Cathode Voltage:	
Heater negative with respect to cathode	200 volts
Heater positive with respect to cathode	200 volts
Grid No. 1 Circuit Resistance, with fixed bias	100 Ω max.

Note 1. Averaged over any audio-frequency cycle of sine-wave form.

Typical Operation : Values for two tubes

DC Plate Voltage	800	1000	1250 volts
DC Grid No. 3 Voltage	0	0	0 volts
DC Grid No. 2 Voltage	300	300	300 volts
DC Grid No. 1 Voltage	-50	-55	-60 volts
Peak AF Grid No. 1 to Grid No. 1 Voltage	100	110	120 volts
Zero Signal DC Plate Current	80	30	20 mA
Maximum Signal DC Plate Current	280	280	280 mA
Maximum Signal DC Grid No. 2 Current	20	20	20 mA
Effective Load Resistance, Plate to Plate	5000	6800	8800 Ω
Power Output	120	160	220 watts

RF Power Amplifier-Class B Single-Sideband
Suppressed-Carrier Operation

(Peak-envelope conditions per tube)

Maximum Ratings : Absolute Values

DC Plate Voltage	1500 volts
DC Grid No. 3 Voltage	100 volts
DC Grid No. 2 Voltage	400 volts
DC Plate Current	250 mA
Plate Input	300 watts
Plate Dissipation	120 watts

NEC 5BHP2 is a 5 inch flat faced cathode ray tube employing electrostatic focus and electrostatic deflection. The tube incorporates post acceleration by use of a spiral band resistance winding which extends from the face of the tube to the vicinity of the deflection plates. By the use of this gradient type of post acceleration, excellent deflection plate linearity and a minimum of pattern distortion can be obtained. Since this tube is aluminized, it is recommended that the post accelerator voltage be no less than 6 kV. for adequate light out put.

GENERAL CHARACTERISTICS

Electrical Data

Heater Voltage :	6.3 Volts
Heater Current :	0.6 ± 10% Amperes
Focusing Method :	Electrostatic
Deflection Method :	Electrostatic

Phosphor

Fluorescence	Green
Phosphorescence	Green
Persistence	Long

Direct Interelectrode Capacitances

Cathode to all other electrodes	4.6 pf
Grid No. 1 to all other electrodes	6.4 pf
X ₊ to X ₋	1.9 pf
Y ₊ to Y ₋	1.5 pf
Post-Accelerator Helix Resistance	200 to 1000 megohms

Mechanical Data

Overall length	464 ± 10 mm
Greatest Diameter of Bulb	133 ± 3 mm
Minimum Useful Screen Diameter	100 mm min.
Bulb Contact (Post Accelerator)	
Recessed Cavity Cap	J1-21
Base (Medium Shell Diheptal 12 pin)	B12-37
Y ₊ Y ₋ trace aligns with Pin No. 1	± 10 Degrees
Trace Alignment Angle between Y ₊ Y ₋ and X ₊ X ₋ trace	90 ± 1 Degrees

Maximum Ratings-Design Center Values

Post Accelerator Voltage	12,000 max. Vdc
Accelerator Voltage	2,000 max. Vdc

Ratio Post Accelerator Voltage to Accelerator Voltage	6 max.
Focusing Voltage	800 max. Vdc
Grid No. 1 Voltage	
Negative Bias Value	200 max. Vdc
Positive Bias Value	0 max. Vdc
Isolation Shield Voltage	2,100 max. Vdc
Deflection Plate Shield Voltage	2,100 max. Vdc
Peak Heater to Cathode Voltage	
Heater Negative with respect to Cathode	180 max. Vdc
Heater Positive with respect to Cathode	180 max. Vdc

Typical Operating Conditions (Note 1)

Deflection plate Shield Voltage (Note 2)	1,575 to 1,700 V
Post Accelerator Voltage	10,000 V
Accelerator Voltage	1,670 V
Isolation Shield Voltage (Note 3)	1,575 to 1,700 V
Focusing Voltage	180 to 590 V
Grid No. 1 Voltage (Note 4)	-50 to -80 V
Deflection Factors	
X ₊ and X ₋	27.6 to 33.5 Vdc/cm
Y ₊ and Y ₋	5.9 to 7.2 Vdc/cm
Deflection Factor Uniformity	2 % max.
Spot position (undeflected) within a 10 mm circle	
Useful Scan	
X ₊ X ₋	100 mm
Y ₊ Y ₋	40 mm
Line Width "A" (Note 5)	0.9 mm max.

Notes

1. All voltages taken with respect to cathode.
2. Linearity improvements can be obtained by proper adjustment of deflection shield voltage which controls the edge effect of the Y₊ Y₋ plate field. Other applications often require Pin # 12 to be connected externally to the isolation shield.
3. The post accelerator spiral band lower end and the isolation shield are connected internally. By voltage potential adjustment on this electrode combination, pin cushion and barrel distortions are minimized.
4. Visual extinction of undeflected spot.
5. For an ΔI_{b3} of 15 μ A.
 $\Delta I_{b3} = I_{b3} - \text{Helical resistance current.}$



NEC CATHODE RAY TUBE

OUTLINE DRAWING TYPE NEC 5BHP2

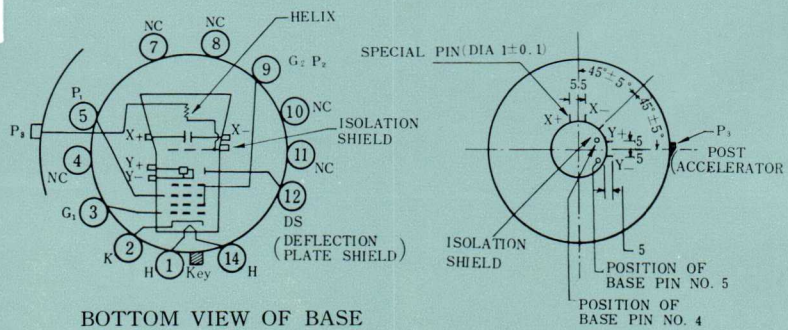
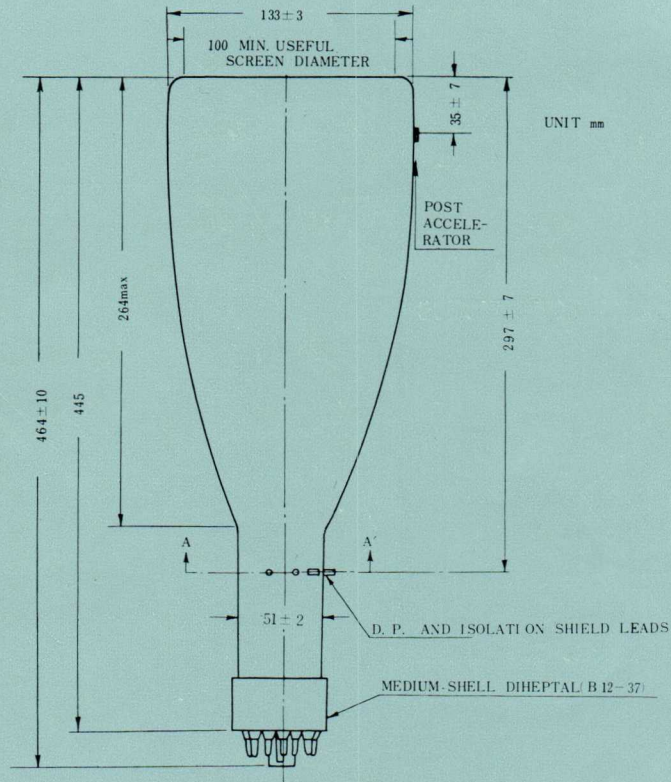

BOTTOM VIEW OF BASE

PIN NO.	ELEMENT
5	FOCUSING ELECTRODE
9	ACCELERATOR

SECTION A-A



Nippon Electric Company Ltd.

Head Office 2, Shiba Mita Shikoku-machi, Minato-ku, Tokyo, Japan
Tel. Tokyo 451-1171(9) • 5121(9) • 5221(9)
Cable Address "MICROPHONE TOKYO"

5 F 6 O R

FORCED AIR - COOLED TETRODE

The NEC 5F6OR is a forced air-cooled tetrode designed for use in power amplifier, power oscillator and frequency multiplier. Its maximum plate dissipation is 450 W.

It features small loss, rugged ceramic-insulated coaxial construction, resulting in small high-frequency loss and high mutual conductance.

In addition, it operates very stably with a large power gain for UHF band. Its maximum input is 1000 W at 500 MHz or less, and 750 W at frequencies up to 1215 MHz.

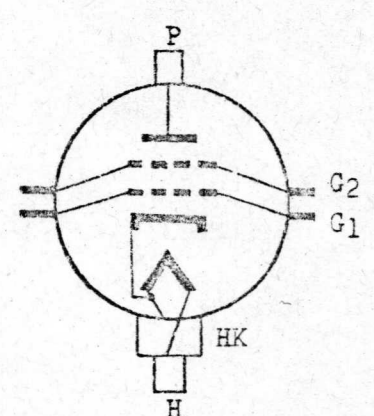
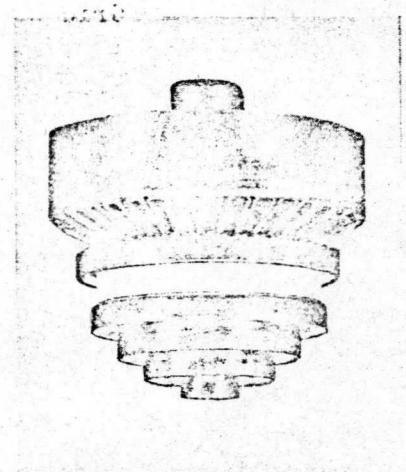

ELECTRICAL DATA :

General Ratings :

Cathode : Indirectly-Heated Oxide
Coated Unipotential

- H : Heater
- HK : Heater Cathode
- G₁ : Grid No. 1
- G₂ : Grid No. 2
- P : Plate

TERMINAL CONNECTION

	Min.	Nom.	Max.	
Heater Voltage	-	6.0	-	V
Heater Current (at standard voltage)	-	5.5	-	A

	Min.	Nom.	Max.	
Min. Pre-Heating Time	120	-	-	sec
Mutual Conductance	21	25	29	mS
Grid No.2 Amplification Factor	11	15	19	
Direct Interelectrode Capacitances :				
Grid No.1 - Cathode	21.2	24.7	28.2	pF
Grid No.1 - Grid No.2	34.8	38.9	43.0	pF
Grid No.2 - Plate	7.0	8.2	9.4	pF
Grid No.1 - Plate	-	0.07	0.12	pF
Grid No.2 - Cathode	-	0.52	0.9	pF
Plate - Cathode	-	0.008	0.02	pF

MECHANICAL DATA :

Dimensions

	Min.	Nom.	Max.	
Overall Length	-	-	61	mm
Max. Diameter	-	-	60.8	mm
Weight (approx.)	-	250	-	g

Mounting Position Any

Cooling :

Radiator : Forced Air-Cooled

Min. Air Flow 0.25 m³/min

Min. Static Pressure	5 mm water
Terminals : Forced Air-Cooled	
Air Flow (approx.)	0.1 m ³ /min
Max. Radiator Temperature	250 °C
Max. Electrode Seal Temperature	250 °C

RF AMPLIFIER, TV LINEAR AMPLIFIER - CLASS AB2

MAXIMUM RATINGS : Frequency, 1215 MHz or less

Frequency	1215 MHz or less
DC Plate Voltage	1500 Vdc
DC Plate Current	500 mA _{dc}
DC Grid No.2 Voltage	600 Vdc
DC Grid No.1 Voltage	-250 Vdc
DC Grid No.1 Current	100 mA _{dc}
Plate Input	750 W
Grid No.2 Input	12 W
Plate Dissipation	450 W

TYPICAL OPERATION : (Values at 200 MHz grounded grid circuit with a 6 MHz bandwidth and the standard cathode voltage per tube)

DC Plate Voltage	1300	1400	Vdc
DC Grid No.2 Voltage	400	400	Vdc

DC Grid No.1 Voltage	-17	-18	Vdc
DC Plate Current			
Max. Signal Current	350	420	mAdc
Zero-Signal Current	100	95	mAdc
DC Grid No.2 Current			
Max. Signal Current	30	35	mAdc
Zero-Signal Current	0	0	mAdc
DC Grid No.1 Current (max. signal current)	25	30	mAdc
Max. Signal Driving Power (approx.)	15	20	W
Max. Signal Plate Output (approx.)	120	170	W

RF POWER AMPLIFIER AND OSCILLATOR --

CLASS C TELEGRAPHY AND FM TELEPHONY

MAXIMUM RATINGS:

Frequency	500 MHz or less	1215 MHz or less	
DC Plate Voltage	2000	1500	Vdc
DC Plate Current	500	500	mAdc
DC Grid No.2 Voltage	600	600	Vdc
DC Grid No.1 Voltage	-250	-250	Vdc
DC Grid No.1 Current	100	100	mAdc
Plate Input	1000	750	W
Grid No.2 Input	12	12	W
Plate Dissipation	450	450	W

TYPICAL OPERATION (circuit, grounded cathode)

Frequency	500	500	500	MHz
DC Plate Voltage	1200	1500	2000	Vdc
DC Grid No.2 Voltage	400	400	400	Vdc
DC Grid No.1 Voltage	-48	-50	-50	Vdc
DC Plate Current	350	500	500	mAdc
DC Grid No.2 Current	0.5	5	4	mAdc
DC Grid No.1 Current	35	60	50	mAdc
Plate Input	420	750	1000	W
Driving Power (approx.)	11.5	21	21	W
Effective Output	230	410	550	W

CHARACTERISTIC VALUES FOR EQUIPMENT DESIGN

<u>Characteristics</u>	<u>Conditions</u>	<u>Allowable Values</u>				<u>Unit</u>	
		<u>Symbol</u>	<u>Nom.</u>	<u>Min.</u>	<u>Max.</u>		
Heater Current		I_f :	5.5	5.0	6.0	A	
Grid No.1 Voltage (1)	$E_b=1400Vdc$ $E_{c2}=400Vdc$	$I_b=250mA_{dc}$ $E_f=6V$	E_{c1} :	-12	-17	-7	Vdc
Grid No.1 Voltage (2)	$E_b=1400Vdc$ $E_{c2}=400Vdc$	$I_b=5mA_{dc}$ $E_f=6V$	E_{c1} :	-	-45	-	Vdc
Grid No.2 Ampli- fication Factor	$E_b=Open$ $E_{c2}=400Vdc$	$I_{c2}=30mA_{dc}$ $\Delta E_{c1}=-30Vdc$	$\mu_{g1\&2}$:	15	11	19	-
Mutual Conductance	$E_b=1400Vdc$ $I_b=250mA_{dc}$	$E_{c2}=400Vdc$ $\Delta E_{c1}=-5Vdc$	g_m :	25	21	29	mS

<u>Characteristics</u>	<u>Conditions</u>	<u>Allowable Values</u>				
		<u>Symbol</u>	<u>Nom.</u>	<u>Min.</u>	<u>Max.</u>	<u>Unit</u>
Peak Emission	$E_f=6V$ $i_s=30A$	es:	-	-	450	V
Plate Power Output	$E_b=2000Vdc$ $E_f=5.5V$ $E_{c1}/I_b=5000mA_{dc}$ $f=480MHz$	Po:	-	480	-	W

Direct Interelectrode Capacitances

Grid No.1 - Cathode	C_{g1k} :	24.7	21.2	28.2	pF
Grid No.1 - Grid No.2	C_{g1g2} :	38.9	34.8	43.0	pF
Grid No.2 - Plate	C_{g2p} :	8.2	7.0	9.4	pF
Grid No.1 - Plate	C_{g1p} :	0.07	-	0.12	pF
Grid No.2 - Cathode	C_{g2k} :	0.52	-	0.9	pF
Plate - Cathode	C_{pk} :	0.008	-	0.02	pF

EQUIPMENT DESIGN CONSIDERATIONS

1. Maximum Ratings

The tabulated maximum electrical and mechanical ratings are limited values above which the performance of the tube may be impaired. Be sure not to exceed the given values under continuous of transient conditions. Equipment design should limit voltage and environmental variations so that ratings will never be exceeded.

2. Cooling System

The relation of the plate dissipation and the plate seal temperature rise is shown in Fig. 1 -- cooling air flow given in parameters.

The terminals other than the plate are cooled by the air flow in the cavity oscillator at a rate of about minimum $0.1 \text{ m}^3/\text{min}$.

As the temperature of the heater terminals is apt to increase, they must be cooled by conducting through the terminal contacts in addition to the air-cooling system.

3. Heater Voltage

As the frequency becomes higher, the temperature of the cathode rises because of counter-heat resulting from the interelectrode electron transit. In order to keep the cathode at the normal temperature, the heater voltage must be dropped. The relation of the operational frequency and the heater voltage is shown in Table 1.

Table 1

<u>Frequency (MHz)</u>	<u>Heater Voltage (V)</u>
400 or less	6.0 - 5.5
400 - 800	5.5 - 5.2
800 - 1200	5.2 - 4.9

4. High Voltage Application and Stop

When applying a voltage to grid No.2 and the plate after pre-heating, it must be applied at a time or to the plate first.

To stop operation, the plate voltage and grid No.2 voltage must be discontinued at a time or grid No.2 voltage must be discontinued at first.

If the voltage is applied to grid No.2 only, grid No.2 input will exceed the rated value and the tube will be damaged.

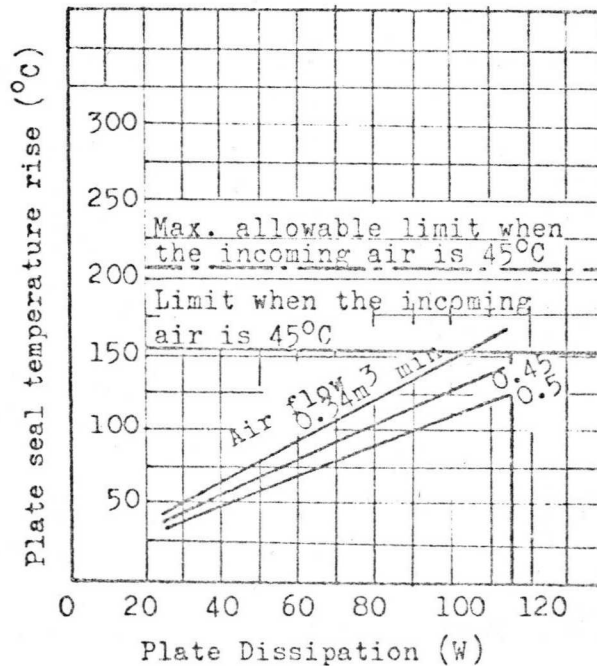

Fig. 1

APPLICATION INSTRUCTIONS

1. Inspection

As soon as you receive the NEC 5F6OR tube(s), inspect whether there is a crack to the ceramic part or a defect -- such as abnormal deformation or damage -- to the metal part or not.

Then, the heater must be tested for its continuity by an ohmmeter.

If there is any damage or defect, please describe the conditions of the damage and mail to the Electron Tube Division, NEC, within two weeks after you received the tube. The serial number of the tube in question must be also stated.

2. Operation

Mount the tube in the socket after making sure that the cooling air is being supplied as prescribed and pre-heat it.

The normal pre-heating time is two minutes but for the first operation it must be pre-heated for about 5 minutes. After pre-heating the tube, apply the voltage to the electrodes and adjust the circuit. As grid No.2 current is very sensitive against the anode circuit load, the non-loaded or lightly-loaded circuit must be carefully adjusted.

If grid No.2 current is excessive, the tube will be damaged.

CONSTANT CURRENT CHARACTERISTICS

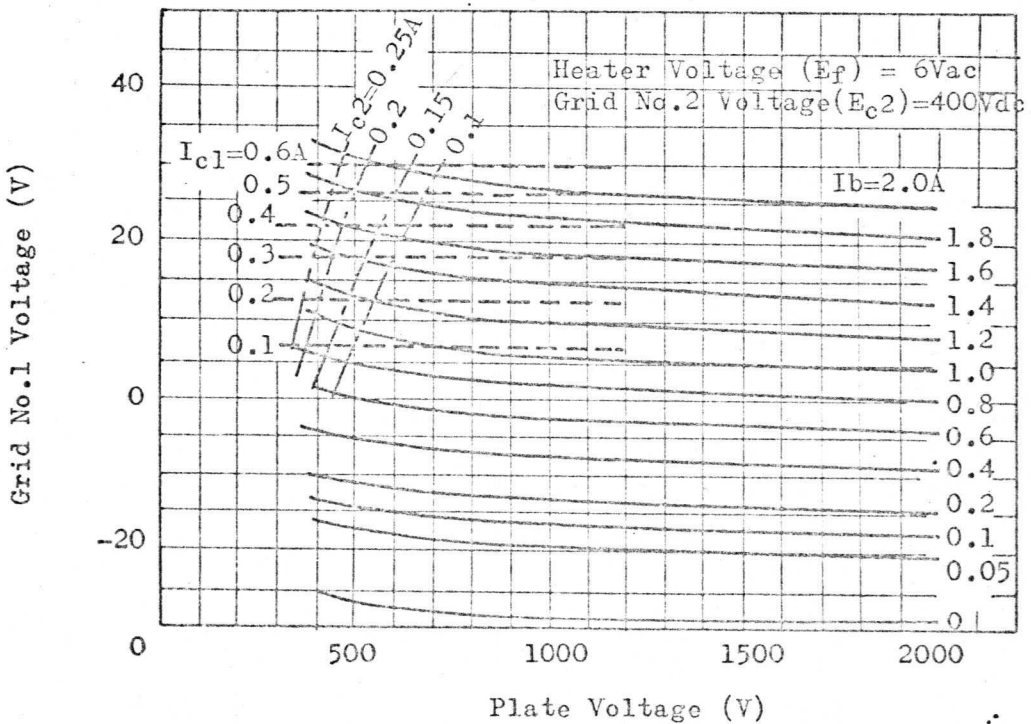
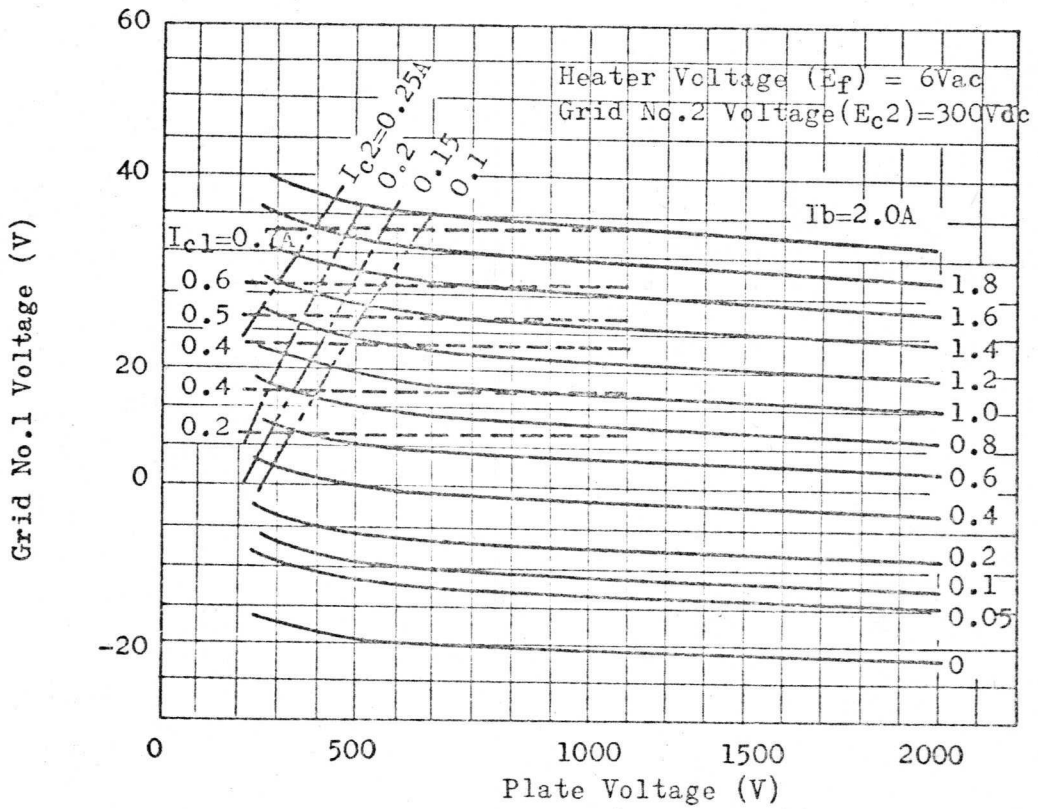

OUTLINE DRAWING

(Unit: mm)

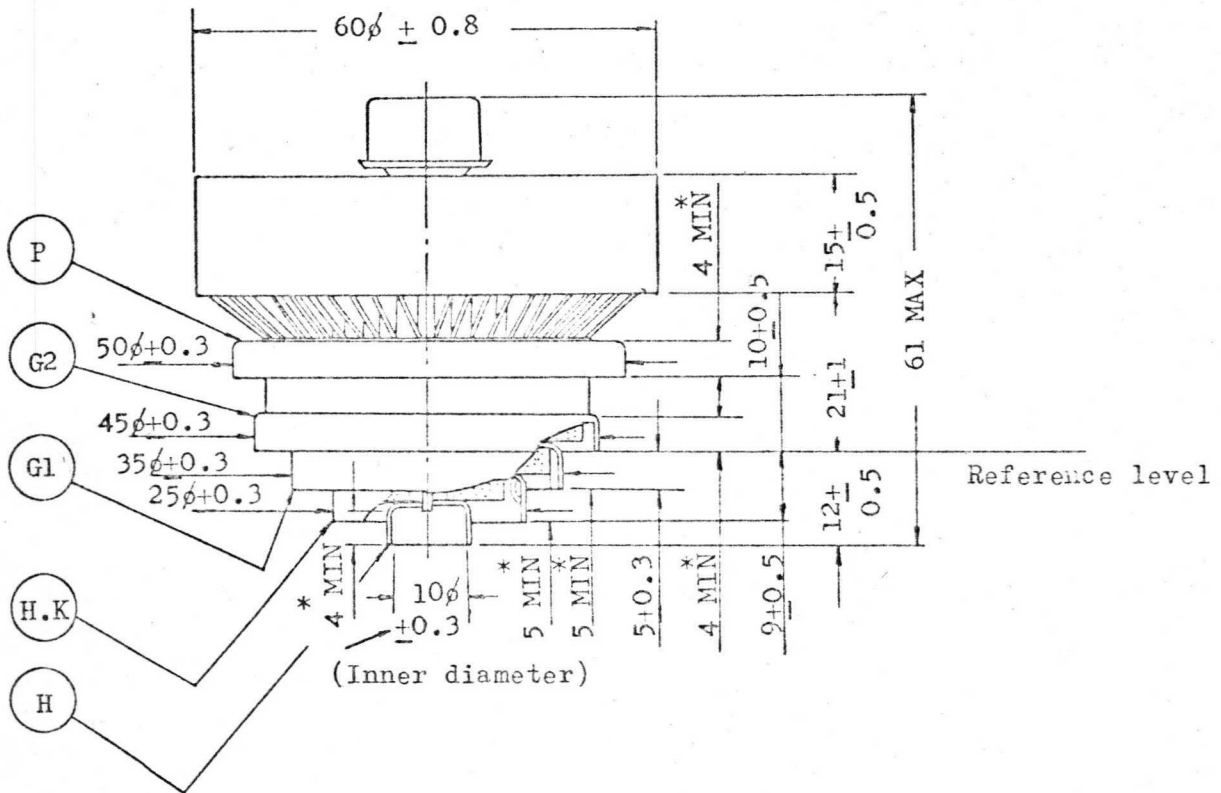

Note: * mark denotes the length of the effective contact surfaces.

7 F 6 4 R

FORCED-AIR-COOLED TETRODE

The NEC 7F64R is a forced-air cooled tetrode designed for use as an amplifier in VHF, FM and TV equipments. It features rugged coaxial ceramic-to-metal seal construction suitable for cavity operation. The anode can dissipate 4KW with a moderate rate of air flow through the integral high efficiency radiator brazed directly to the anode. The cathode is a mesh type filament which provides a high transconductance and trouble-free operation. The mesh type grids are fabricated by a novel technique-called photoetching process and assure very reliable performance.

Maximum ratings apply at frequencies up to 250 MHz.

ELECTRICAL DATA:

GENERAL DATA:

Filament: Thoriated Tungsten

Voltage 6 volts

Current 68 amps

Maximum Starting Current ... 140 amps

Transconductance ($I_b=1$ amp) 36 millimhos

Amplification Factor, Grid No.2 to Grid No.1 7.5

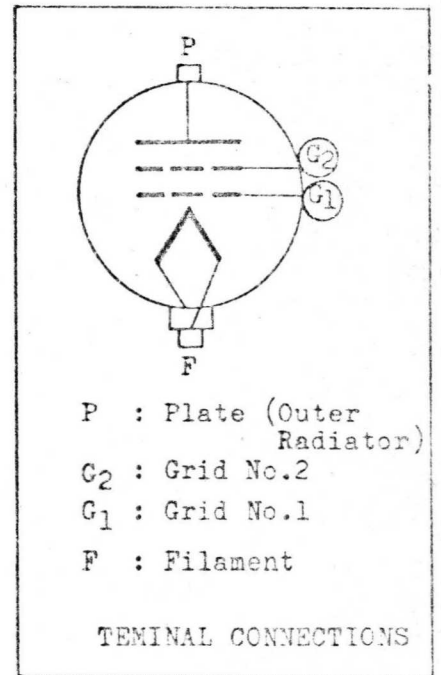
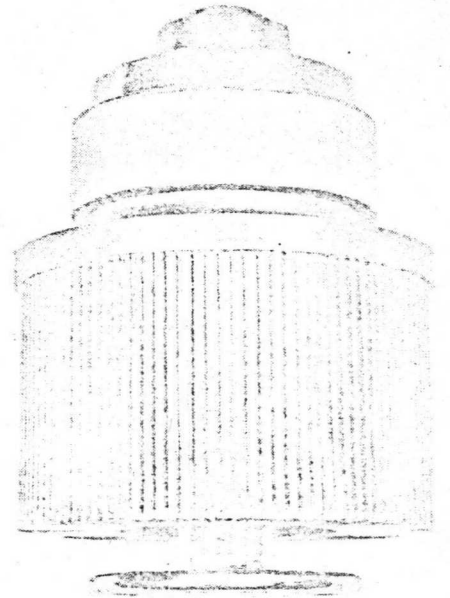

Interelectrode Capacitances:

Grid No.1 to Plate	0.57 $\mu\mu\text{F}$
Filament to Plate	0.08 $\mu\mu\text{F}$
Grid No.2 to Plate	17 $\mu\mu\text{F}$
Grid No.1 to Filament	48 $\mu\mu\text{F}$
Grid No.1 to Grid No.2	70 $\mu\mu\text{F}$
Frequency for Maximum Ratings	250 MHz

MECHANICAL DATA:

Dimensions:

Maximum Diameter	124.5 mm
Maximum Overall Length	178 mm
Net Weight (approx.)	2.4 kg

Mounting Position: Vertical, anode up or down

Cooling:

To plate: Forced-air cooling required

Minimum air flow	5 m^3/min
Minimum static pressure (across radiator).	40 mm of water

To filament and grid seals:

Adequate forced-air flow should be delivered uniformly around the circumference of each seal to limit the temperature below their maximum ratings.

Minimum air flow	0.3 m^3/min
Maximum incoming air temperature	40 $^{\circ}\text{C}$
Maximum radiator temperature	250 $^{\circ}\text{C}$
(Measured at the upper end of core)	
Maximum seal temperature	250 $^{\circ}\text{C}$

RE LINEAR POWER AMPLIFIER - CLASS AB₁
 (SSB Suppressed-carrier operation
 Single-tone modulation conditions per tube)

MAXIMUM RATINGS: Absolute Values

DC Plate Voltage	7000 volts
DC Grid No.2 Voltage	1200 volts
Max. Signal DC Plate Current	2.8 amps
Plate Dissipation	4 kw
Grid No.2 Dissipation	150 watts

TYPICAL OPERATION: (in grid drive circuit)

DC Plate Voltage	5000 volts
DC Grid No.2 Voltage	900 volts
DC Grid No.1 Voltage	-125 volts
Peak RF Grid No.1 Voltage	125 volts
Max. Signal DC Plate Current	1.58 amps
Zero-Signal DC Plate Current	200 mA
Max. Signal DC Grid No.2 Current	35 mA
Max. Signal Driving Power (approx.)	0 watts
Max. Signal Plate Power Output (approx.)	5.1 kW

RF POWER AMPLIFIER - CLASS B TELEVISION
 (Synchronizing-peak level conditions per tube)

MAXIMUM RATINGS: Absolute Values

DC Plate Voltage	7000 volts
DC Grid No.2 Voltage	1200 volts

DC Plate Current	2.8 amps
Plate Dissipation	4 kW
Grid No.2 Dissipation	150 watts
Grid No.1 Dissipation	50 watts

TYPICAL OPERATION: (in cathode drive circuit)

DC Plate Voltage	4500 volts
DC Grid No.2 Voltage	500 volts
DC Grid No.1 Voltage	-70 volts
DC Plate Current:	
Synchronizing-peak level	1.7 amps
Pedestal-level	1.2 amps
DC Grid No.2 Current:	
Synchronizing-peak level	17 mA
Pedestal-level	8 mA
DC Grid No.1 Current:	
Synchronizing-peak level	84 mA
Pedestal-level	28 mA
Driving Power:	
Synchronizing-peak level (approx.)	172 watts
Pedestal-level (approx.)	123 watts
Plate Power Output	
Synchronizing-peak level (approx.)	4 kW
Pedestal-level (approx.)	2.25 kW

RF POWER AMPLIFIER AND OSCILLATOR - CLASS C TELEGRAPHY AND FM TELEPHONY

(Key down conditions per tube without modulation)

MAXIMUM RATINGS: Absolute Values

DC Plate Voltage	7000	volts
DC Grid No.2 Voltage	1200	volts
DC Grid No.1 Voltage	-500	volts
DC Plate Current	2.2	amps
Plate Dissipation	4	kW
Grid No.2 Dissipation	150	watts
Grid No.1 Dissipation	50	watts

TYPICAL OPERATION: (in grid drive circuit)

DC Plate Voltage	5000	6000	volts
DC Grid No.2 Voltage	500	500	volts
DC Grid No.1 Voltage	-170	-185	volts
Peak RF Grid No.1 Voltage	240	275	volts
DC Plate Current	1.39	1.71	amps
DC Grid No.2 Current	60	78	mA
DC Grid No.1 Current	100	140	mA
Driving Power (approx.) (Note 1)	22.8	36.3	watts
Plate Power Output (approx.)	5.56	8.2	kW

(Note 1) Circuit loss is not included.

APPLICATION INSTRUCTIONS

1. INITIAL INSPECTION

When NEC 7F64R is received, it should be unpacked and inspected as soon as possible. In handling the 7F64R, extreme care should be taken to protect the tube from undue shock and vibration, since the thoriated-tungsten filaments, the metal-to-ceramic seals or other intricate tube parts may easily become damaged.

A careful inspection should be made for any visible damage, such as cracked ceramic or deformed metal parts, which may have occurred in transit. The tube should then be checked with an ohmmeter to determine if a inter-electrode short-circuit or open-filament has occurred. If no failure is assured by the abovementioned inspection, the tube should be installed in the socket and all electrical connections made.

Rated filament voltage should be applied and the filament current checked to see if it agree with the value indicated on the data sheet attached to the tube.

When the filament voltage and current measurement is being performed, care should be taken to calibrate the voltmeter and ammeter accurately and to prevent the errors caused by voltage drops of socket and leads carrying a heavy current.

If there is any evidence of damage in transit, report should be prepared and mailed to the Sales Department, Electron Device Division of NEC, within fifteen-days. The serial number identifying each individual tube appears on the bottom surface of the anode.

2. OPERATION

Before mounting in the socket, following precautions should be observed.

The ceramic envelope and other external parts of the 7F64R should be kept free from accumulated dust to minimize surface leakage and the

possibility of arc-over. It is recommended that dust be wiped from the ceramic envelope and from other external parts of the tube. This should be done when the tube is cold, using a clean soft lint-free cloth (if available, moistened with alcohol). If dust are adhered to the cavity or socket, it should be cleaned and check should be made whether a deformed or damaged contact fingers exists in order to assure good electrical contacts to the tube terminals. When the tube is pushed into the socket, it should be done carefully keeping tube axis right on the axis of the socket. If it is felt excessively tight in inserting the tube never force it down. Check the alignment of the contact fingers of the socket. After filament and grid No.1 low voltage supplies have been on for 10 minutes, apply plate and grid No.2 voltages and operate the tube with reduced driving power for an additional 30 minutes. All tuning adjustments should be made during this period. Normal driving power may then be applied and final tune-up performed.

3. TUBE PROTECTION

All protective circuits and interlocks such as over-current relays, air interlocks etc. to remove power under fault conditions should be checked regularly in order to assure their proper functioning. If adequate protection is not provided, fault over loads may result in the following conditions.

- (a) Liberation of gas in the tube
- (b) Gross damage to the internal elements, e.g. burn out of grid wires etc.
- (c) External arcing-over between electrode terminals, with damages to seals and possible crack of ceramic envelope.

A tube which became gassy can often be cleaned up successfully by patient reaging, according to the schedule described in the preceding paragraph. The other conditions listed above are usually catastrophic.

4. TUBE CARE

The ceramic envelope and other external parts of the 7F64R should be kept free from accumulated dust to minimize surface leakage and the

possibility of arc-over. The ceramic surface should never come in contact with metallic pieces such as tools, because the contact will leave some traces on the surface which may impair the insulation. On the same reason, writing on the ceramic surface with lead pencil etc. is prohibited. All tube terminals must be kept bright and clean to provide good electrical contacts.

In transportation and storage of the 7F64R, care should be taken to protect the tube from rough handling that would damage the tube. It should be stored in its shipping container with the filament end up and should be protected from moisture, extreme temperature variations and undue shock and vibration. When packing the tube for reshipment, it should be packed in its own shipping container as in the initial shipment. The Tube Return Authorization Sheet supplied together with each tube should be filled out and forwarded, whenever the tube is to be returned to the factory.

EQUIPMENT DESIGN CONSIDERATION

1. MAXIMUM RATINGS AND TYPICAL OPERATING CONDITIONS

Maximum values given either for electrical or for mechanical ratings in the tabulated data are limitings values above which, if exceeded, serviceability of any individual tube may be impaired. Maximum rating applies independently on each item and does not form a set of satisfactory operating conditions. When designing circuit, therefore, it is necessary to insure that the maximum ratings will never be exceeded under any conditions, even momentarily. The equipment designer must make allowances for any unusual conditions of supply-voltage fluctuation or load variation and for manufacturing tolerances in the equipment itself and the tube.

The typical operating conditions, given in the tabulated data, do not include the circuit losses, hence usefull power output to the load may be less than that indicated, depending upon the frequency of operation and the circuit efficiency.

2. ELECTRICAL CONDITIONS

FILAMENT VOLTAGE

The cathode of the NEC 7F64R is of mesh type thoriated-tungsten filaments. Since the life of the tube can be prolonged by operating it at the lowest filament voltage which will enable the tube to give satisfactory performance, it is preferable to use with as low filament voltage as possible within the range of 10 percent down from nominal rated value.

The filament should never be operated, under any circumstances, at higher, by 5 percent of rated value, than nominal voltage.

MONITORING OF OPERATION

Suitable meters should be provided for monitoring filament voltage, dc plate voltage, plate current, dc grid No.2 voltage, grid No.2 current, dc grid No.1 voltage and grid No.1 current. Elapsed-time meter should be installed to read total hours of filament operation. The evaporation of active materials from the filament starts to take place even when the filament voltage alone is applied. Therefore, the tube life should be counted by total hours of filament operation.

GRID NO.1 BIAS

In class-AB or class-B RF linear power amplifier service, the 7F64R should be operated with grid bias obtained from a fixed dc source of good voltage regulation. If tubes are used in parallel or in push-pull, the grid circuit of each tube should be provided with a separate bias adjustment to balance the grids and plate currents. The zero signal dc plate current has a critical influence on the linearity. Therefore, grid No.1 bias voltage should be chosen for the best compromise between zero-signal plate dissipation and distortion.

In plate-modulated class-C RF power amplifier service (telephony), the tube should be supplied with bias from a grid resistor,

or from a suitable combination of grid resistor and fixed supply or from grid resistor and cathode resistor. The cathode resistor should be by-passed for both audio and radio frequencies. The combination method of grid resistor and fixed supply has the advantage of not only protecting the tube from damage through loss of excitation but also of minimizing distortion by bias voltage compensation.

In class-C RF telegraphy service, it is similar to plate-modulated class-C RF power amplifier service (telephony).

GRID NO.2 VOLTAGE

Protection against the over loading of grid No.2 should be provided by an over current relay and by interlocking the grid No.2 supply so that plate voltage must be applied before grid No.2 voltage is applied. Variation of load impedance causes variations of plate and grid No.2 currents. Light load increases grid No.2 current while decreasing plate current and results in excessive grid No.2 dissipation. Heavy load tends to increase plate current and decrease grid No.2 current which results in lower efficiency and excessive plate dissipation.

The grid No.2 current may reverse under certain conditions and produce negative current indications on the grid No.2 ammeter. This is a normal characteristic of most tetrodes. Therefore, a current path from grid No.2 to cathode must be provided by a bleeder resistor, and is arranged to pass an adequate bleeder current per connected grid No.2.

In the usual tetrode amplifier, where no signal voltage appears between cathode and grid No.2, grid No.2 dissipation is equal to the product of the dc grid No.2 voltage and the dc grid No.2 current. When signal voltage appears between cathode and grid No.2, as in the case of cathode driven amplifier, grid No.2 dissipation may become much more than the value obtained in the aforementioned case.

In the case of class-AB or class-B RF linear power amplifier, care should be taken to prevent the increase of distortion caused by variation of grid No.2 voltage.

3. COOLING SYSTEM

Sufficient forced-air cooling of 7F64R must be provided the air flow of $5 \text{ m}^3/\text{min}$ or more through radiator for use with a plate dissipation of 4 kW.

The filament, grid No.1 and grid No.2 seals are cooled by air-flow of not less than $0.3 \text{ m}^3/\text{min}$.

When the cooling of filament seals and radiator of this tube is accomplished by the common forced-air supply, forced-air flow should be directed from filament seals to radiator through the grid No.1 and No.2 contacts.

A suitable air filter is required in the air supply system. Care should be given to clean or replace the filter at intervals in order that accumulated dust will not obstruct the flow of air. The required static pressure versus air-flow characteristic of radiator of the NEC 7F64R is shown in Fig. 1. Allowances for pressure drops in an air filter, ducts and louvers etc., should be made in selecting a blower.

Since the cooler operation of the tube prolongs tube life markedly, adequate margin in air flow should be provided. The cooling system should be properly installed to insure safe operation of the tube under all conditions and, for this reason, should be electrically interlocked with the filament, plate and grid No.2 power supplies.

This arrangement is necessary to make sure that the tube is supplied with air before any voltage is applied. Air flow or pressure interlocks which open the filament and plate power transformer primaries is necessary for protecting the tube when the air flow is insufficient or ceases.

4. FAULT PROTECTION

The handling of high power requires particular attention to the removal of power under fault conditions, since the large amount of energy involved can seriously damage the tube or the equipment if not properly controlled.

The ground lead of the plate circuit of each tube should be connected in series with the coil of quick acting overload relay, adjusted to open the circuit breakers in the primary of rectifier transformer at slightly higher than normal operating plate current. The total response time required for the operation of relay and circuit breakers should be 1/10 second or less. As mentioned before the grid No.2 circuit should also be equipped with similar over load relays. Under-voltage relay in the grid No.1 circuit may be required for some application.

The above mentioned discussion presents information necessary to obtain satisfactory and economical performance of the NEC 7F64R under normal operating conditions. For information concerning specific tube problem or applications not covered here, consult the Engineering Department, Electron Device Division, Nippon Electric Company Ltd., 1753 Shimo-numabe, Nakahara-ku Kawasaki City, Japan.

Fig 1 AIR FLOW VS PRESSURE DROP CHARACTERISTIC OF RADIATOR

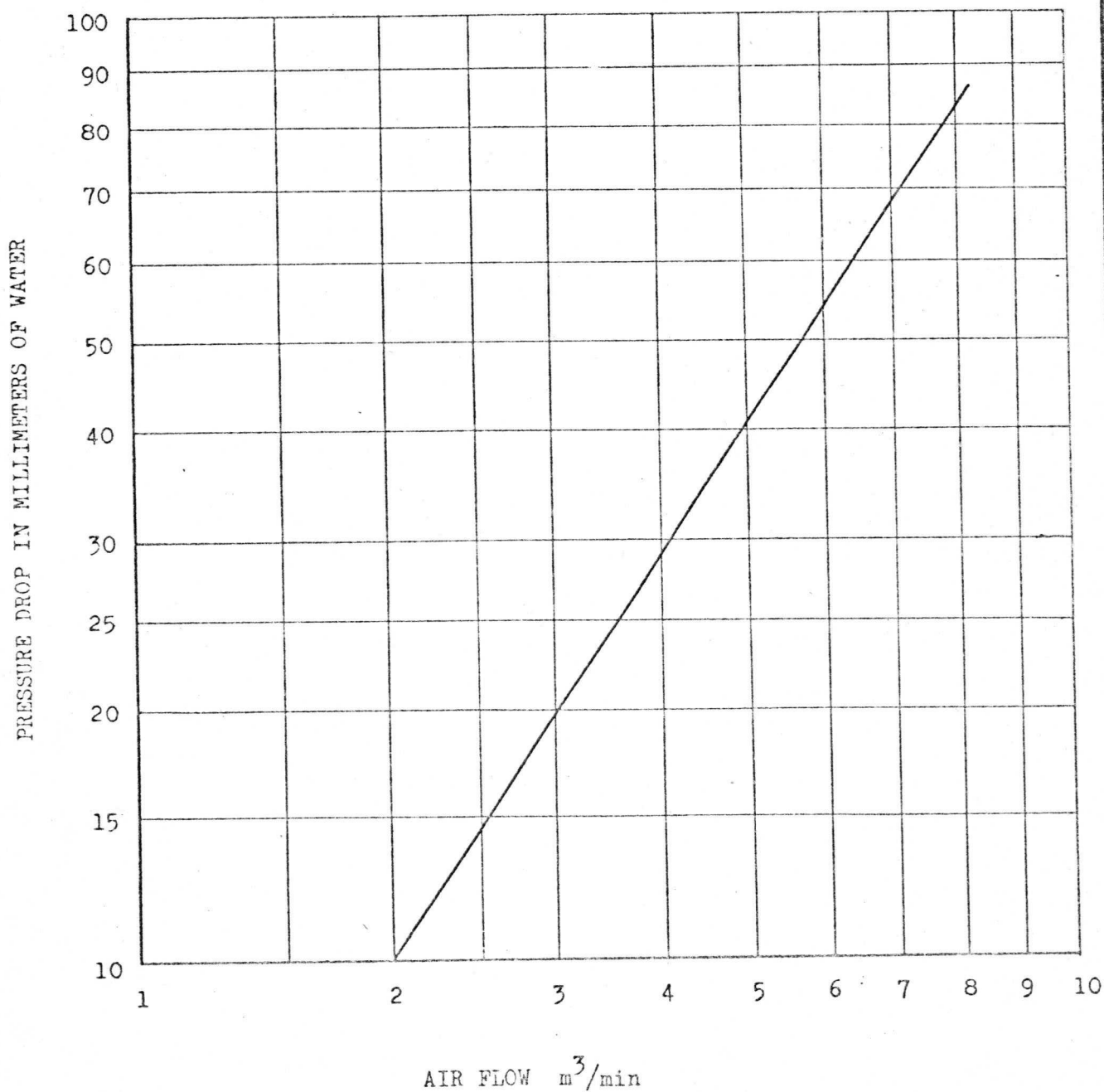

Fig 2 CONSTANT CURRENT CHARACTERISTICS

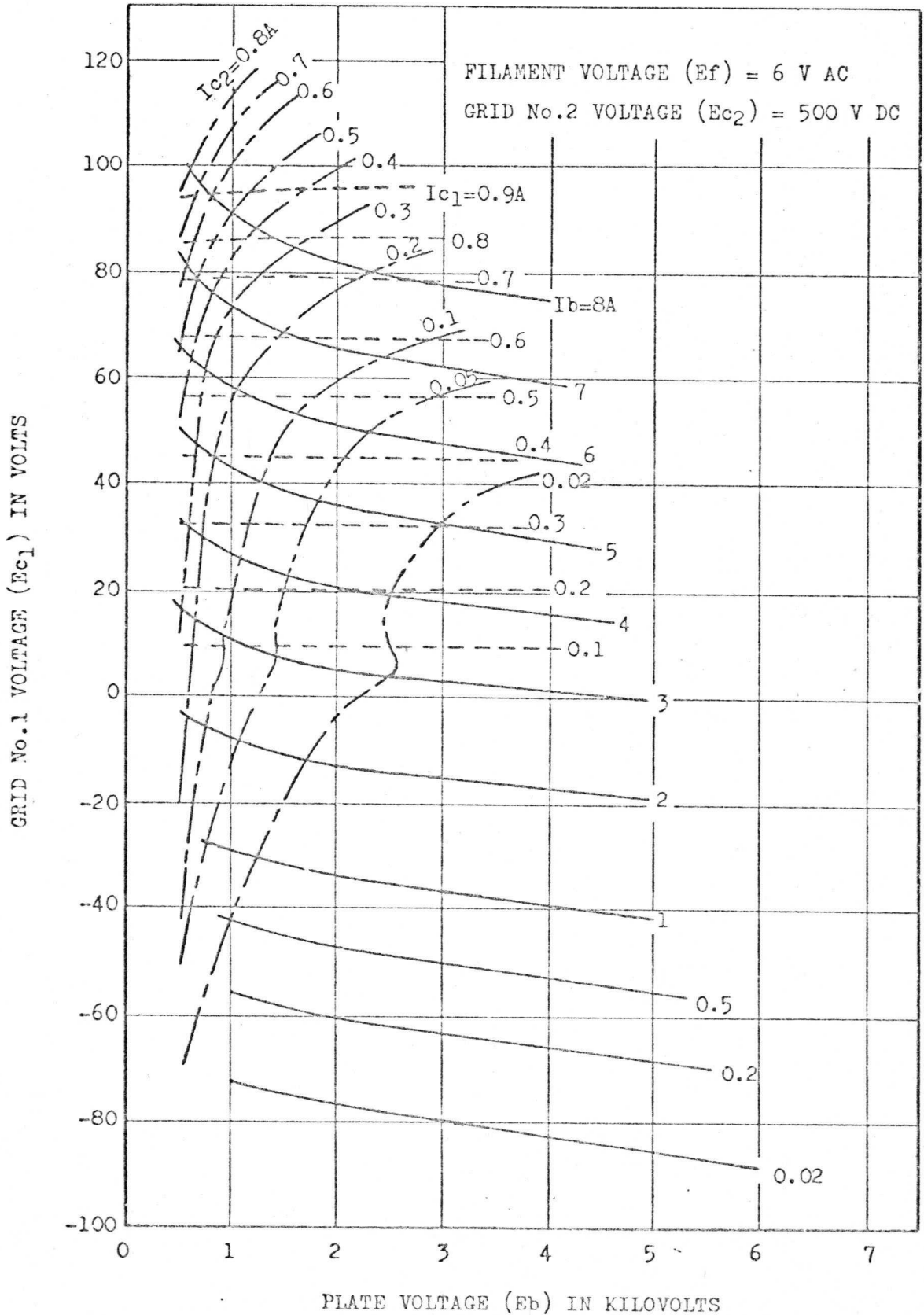

Fig 3 CONSTANT CURRENT CHARACTERISTICS

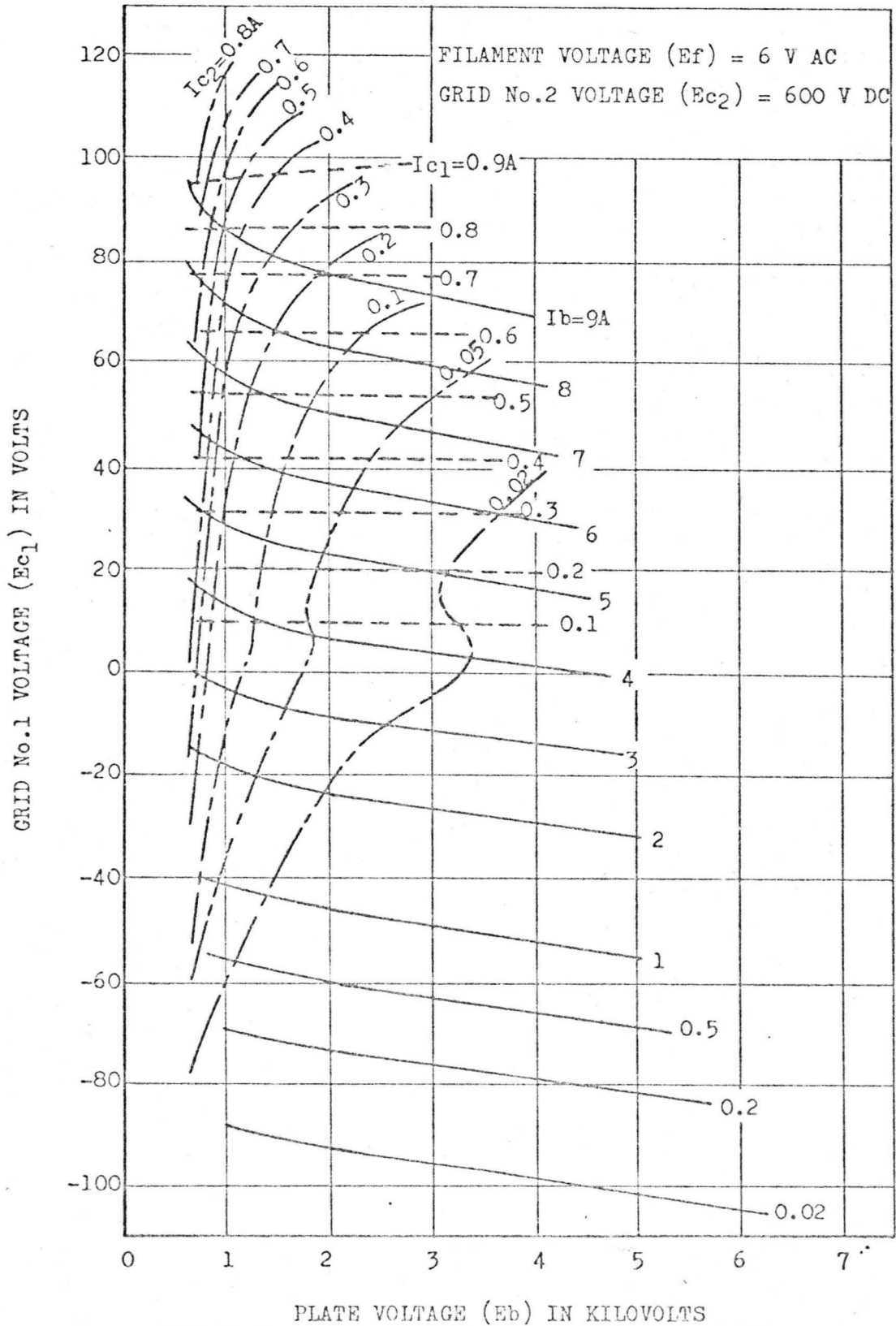
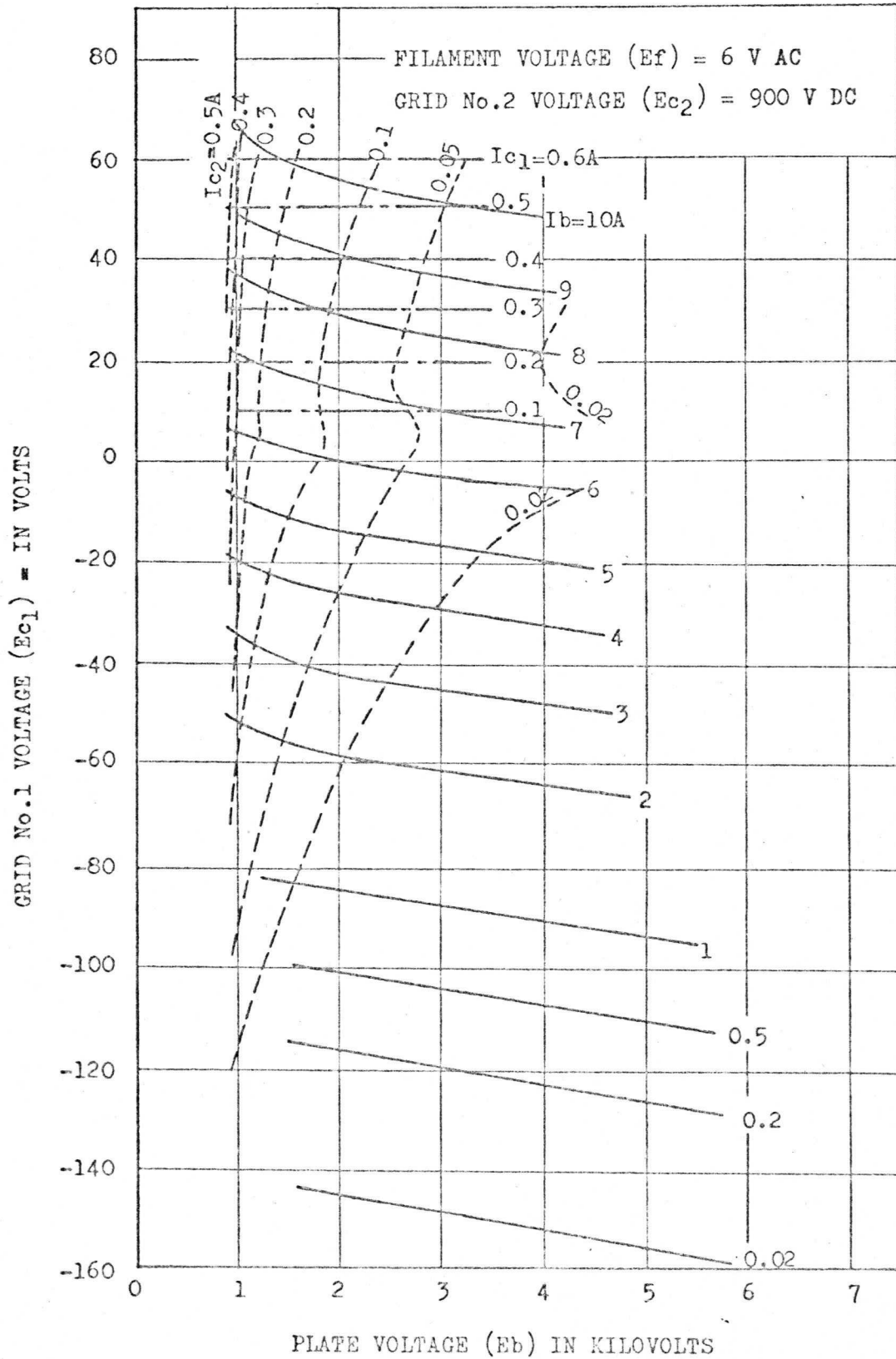
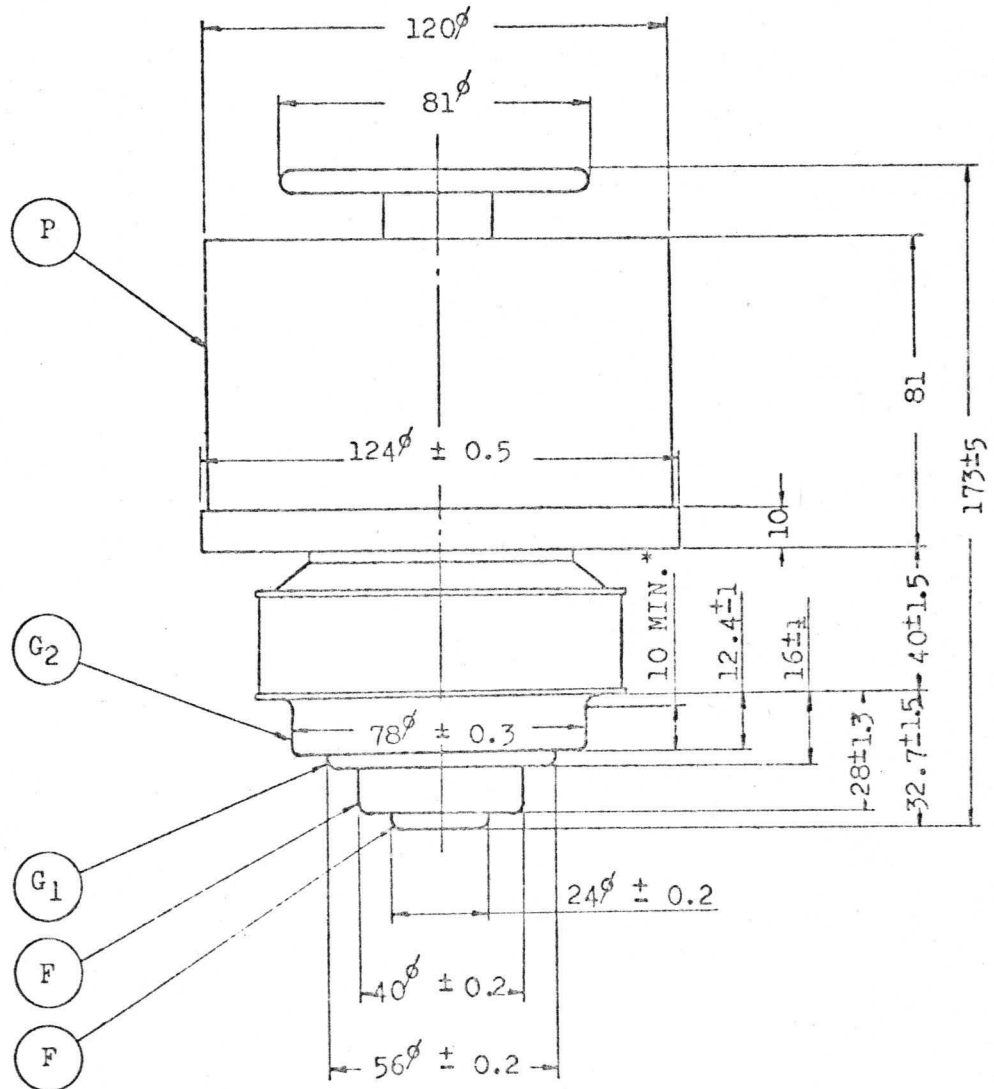

Fig 4 CONSTANT CURRENT CHARACTERISTICS



(Unit in mm)

Fig 5 OUTLINE DRAWING



* $78\phi \pm 0.3$ TOLERANCE APPLIES

7 F 7 1 R A

FORCED-AIR COOLED TETRODE

The NEC 7F71RA is a forced-air cooled tetrode designed for use as an amplifier in VHF-TV and FM transmitters. It features rugged coaxial ceramic-to-metal sealed construction suitable for cavity operation at high frequencies. The cathode consists of a mesh type thoriated tungsten filament. The novel technique, including photoetching process, are used throughout the fabrication of the mesh type grids.

With these modern constructions and new techniques being employed, the NEC 7F71RA has high transconductance essential for high gain and high efficient operation and assures long life and highly reliable operation. The anode, with the integral radiator, is capable of dissipating 3.5 kilowatts of power with moderate rate of air flow.

Maximum ratings apply at frequencies up to 250 MHz.

ELECTRICAL DATA:

GENERAL DATA:

Filament: Thoriated Tungsten

Voltage	4	volts $\pm 5\%$
Current	78	amps.
Maximum Starting Current	160	amps.
Minimum Heating Time	5	sec.

Transconductance (I _b =1.6 amps.)	72 millimohs
Amplification Factor, Grid No.2 to Grid No.1	10.5

INTERELECTRODE CAPACITANCES:

Grid No.1 to Plate	0.3 μ F
Filament to Plate	0.04 μ F
Grid No.1 to Filament	54 μ F
Grid No.1 to Grid No.2	100 μ F
Grid No.2 to Plate	14 μ F
Frequency for Maximum Ratings	250 MHz

MECHANICAL DATA

Dimensions:

Maximum Overall Length	165 mm
Maximum Diameter	130 mm
Net weight (aprox.)	2.7 kg

Terminal Connections:

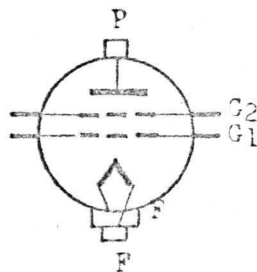

- P : Plate
- G₂ : Grid No.2
- G₁ : Grid No.1
- F : Filament

MOUNTING POSITION: Vertical, anode up or down

Cooling:

To Plate: Forced air cooling required

Minimum air flow	4.5 m ³ /min.
Minimum static pressure	45 mm of water

To filament and grid seals: *

Adequate forced-air flow should be delivered uniformly around the circumference of each seal to limit the temperature below the maximum rating.

Minimum air flow	0.5 m ³ /min.
Maximum incoming air temperature	45 °C
Maximum radiator temperature	250 °C
Maximum seal temperature	250 °C

RF POWER AMPLIFIER-CLASS B TELEVISION

(Synchronizing peak level conditions per tube)

MAXIMUM RATINGS: Absolute Values

DC Plate Voltage	5,000 volts
DC Grid No.2 Voltage	1,000 volts
DC Grid No.1 Voltage	-500 volts
DC Plate Current	2.4 amps.
Plate Dissipation	3.5 kW
Grid No.2 Dissipation	50 watts
Grid No.1 Dissipation	20 watts

TYPICAL OPERATION: (in cathode drive circuit)

DC Plate Voltage	2,500	3,000	volts
DC Grid No.2 Voltage	500	500	volts
DC Grid No.1 Voltage	-40	-40	volts
Zero Signal DC Plate Current	0.5	0.5	amps.
Peak RF Grid No.1 to Cathode Voltage:			
Synchronizing peak level	44	60	volts

Pedestal level	34	47	Volts
DC Plate Current:			
Synchronizing peak level	1.11	1.6	amps.
Pedestal level	0.88	1.22	amps.
DC Grid No.2 Current:			
Synchronizing peak level	50	70	mA
Pedestal level	25	35	mA
DC Grid No.1 Current:			
Synchronizing peak level	10	70	mA
Pedestal level	0	17	mA
Driving Power (approx.):			
Synchronizing peak level	39	78	watts
Pedestal level	23	45	watts
Plate Power Output (approx.):			
Synchronizing peak level	1.36	2.72	kW
Pedestal level	0.8	1.6	kW
Frequency	220	220	MHz
Bandwidth (-1 dB)	7	7	MHz

RF POWER AMPLIFIER AND OSCILLATOR-CLASS C

TELEGRAPHY AND FM TELEPHONE

(Key-down condition per tube without modulation)

MAXIMUM RATINGS: (Absolute Value)

DC Plate Voltage	5,000	volts
DC Grid No.2 Voltage	1,000	volts
DC Grid No.1 Voltage	-500	volts

DC Plate Current	1.8 amps.
Plate Dissipation	3.5 kW
Grid No.2 Dissipation	50 watts
Grid No.1 Dissipation	20 watts

TYPICAL OPERATION: (in grid drive circuit)

DC Plate Voltage	3,500 volts
DC Grid No.2 Voltage	500 volts
DC Grid No.1 Voltage	-150 volts
Peak RF Grid No.1 Voltage	185 volts
DC Plate Current	1.3 amps.
DC Grid No.2 Current	70 mA
DC Grid No.1 Current	85 mA
Driving Power (approx.)	16 watts
Plate Power Output (approx.)	3.1 kW

PLATE DISSIPATION VS PLATE SEAL AND PLATE CORE TEMPERATURE CHARACTERISTICS

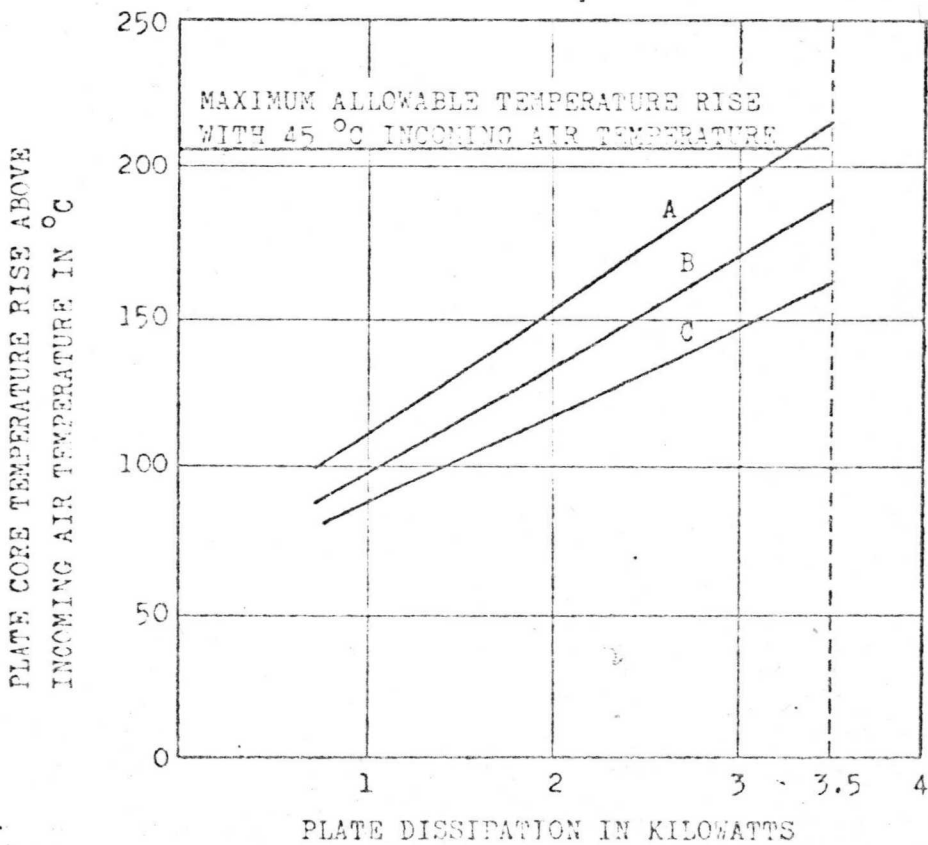
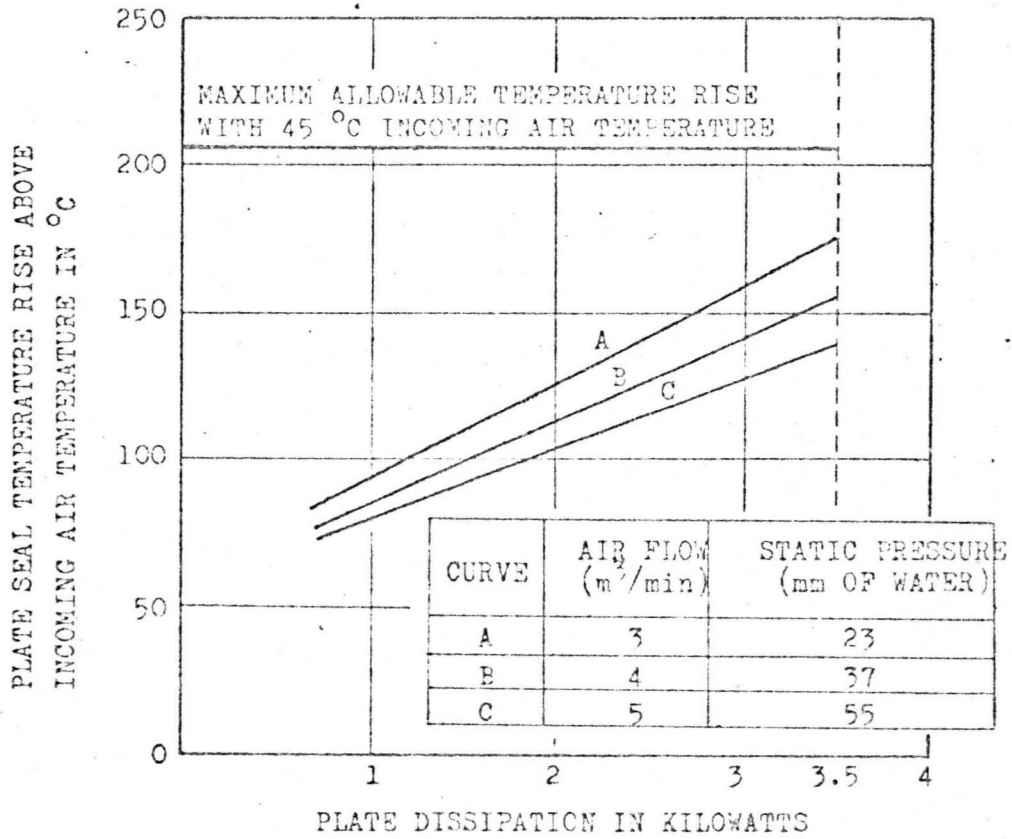

CONSTANT CURRENT CHARACTERISTICS

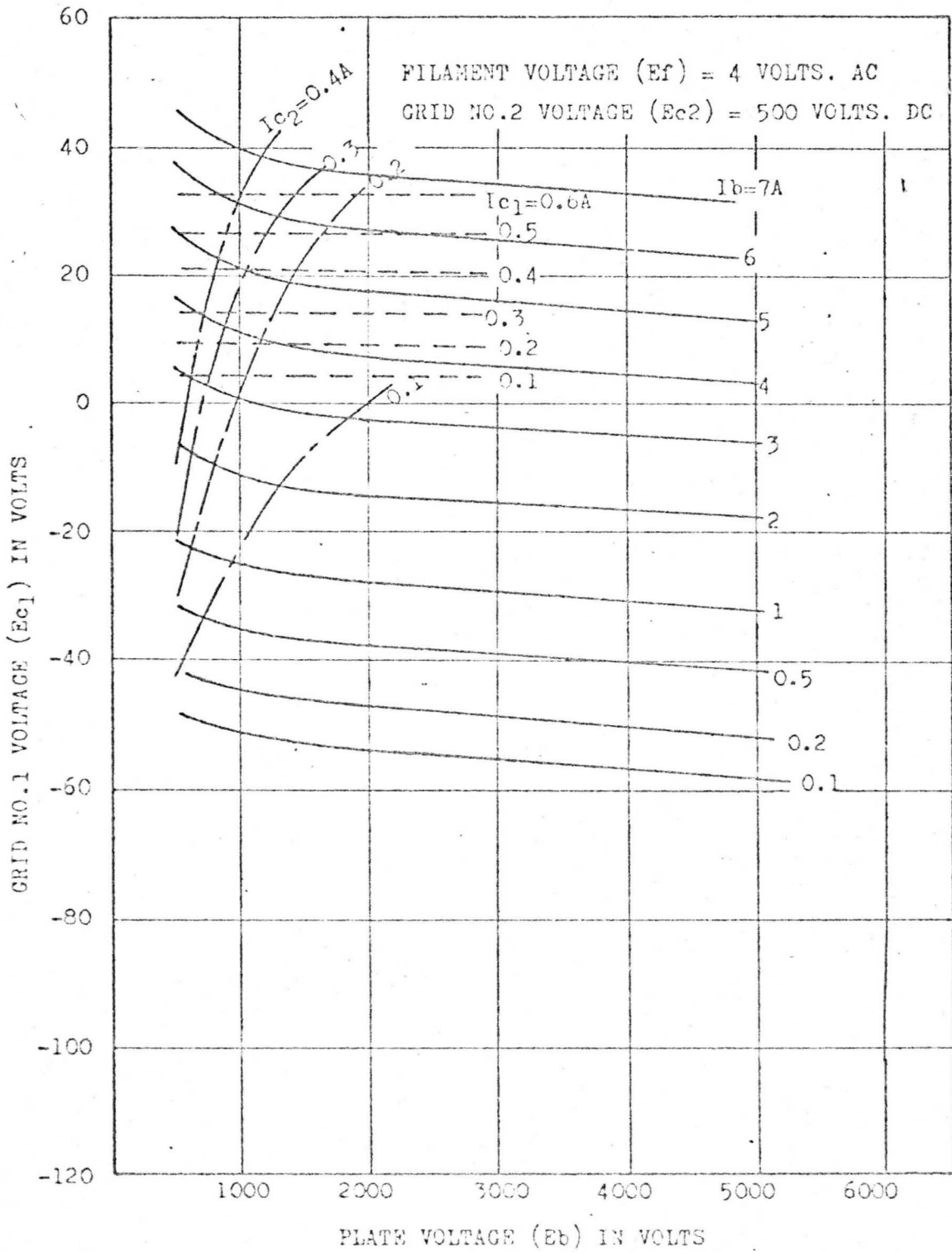

CONSTANT CURRENT CHARACTERISTICS

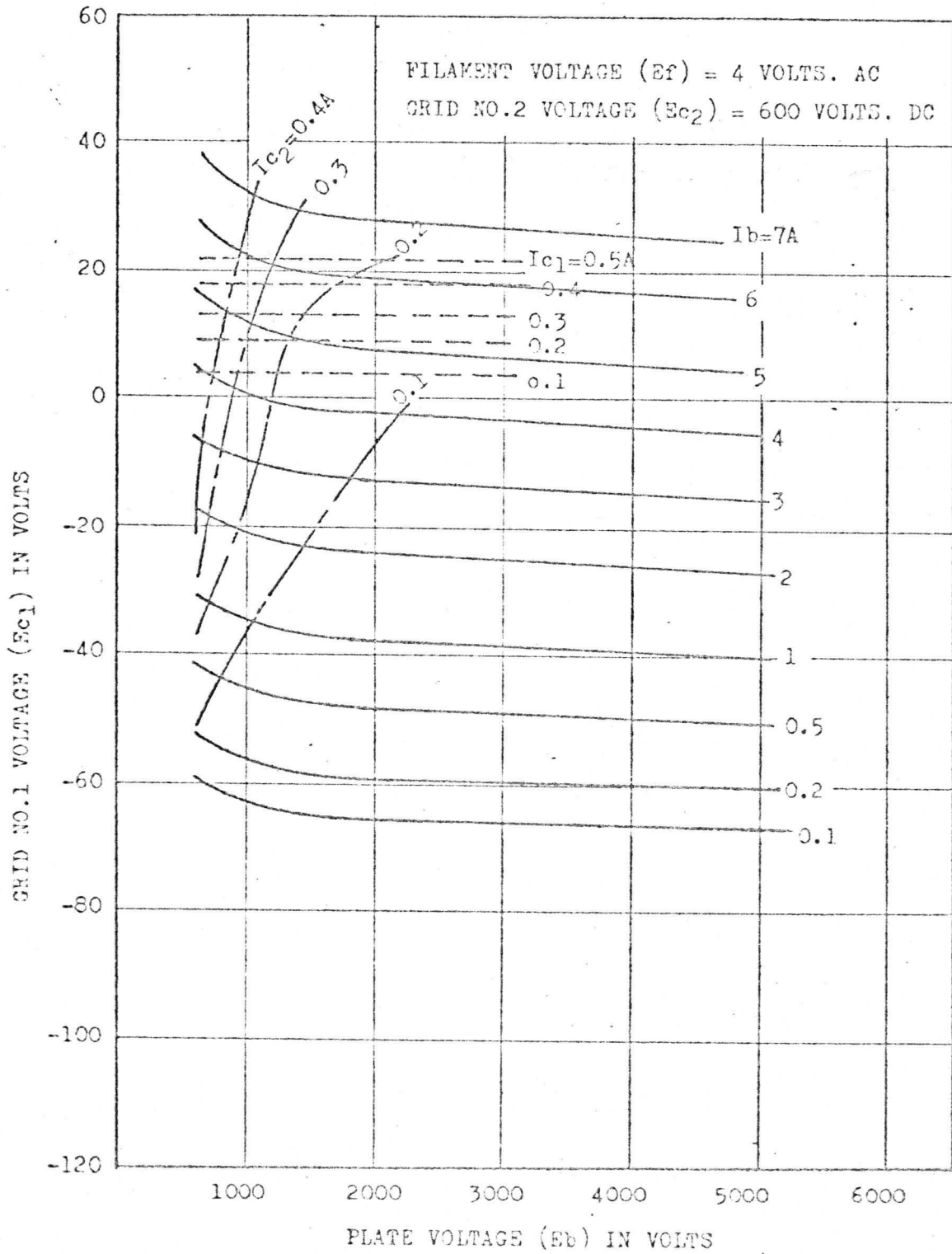

OUTLINE DRAWING

UNIT : mm

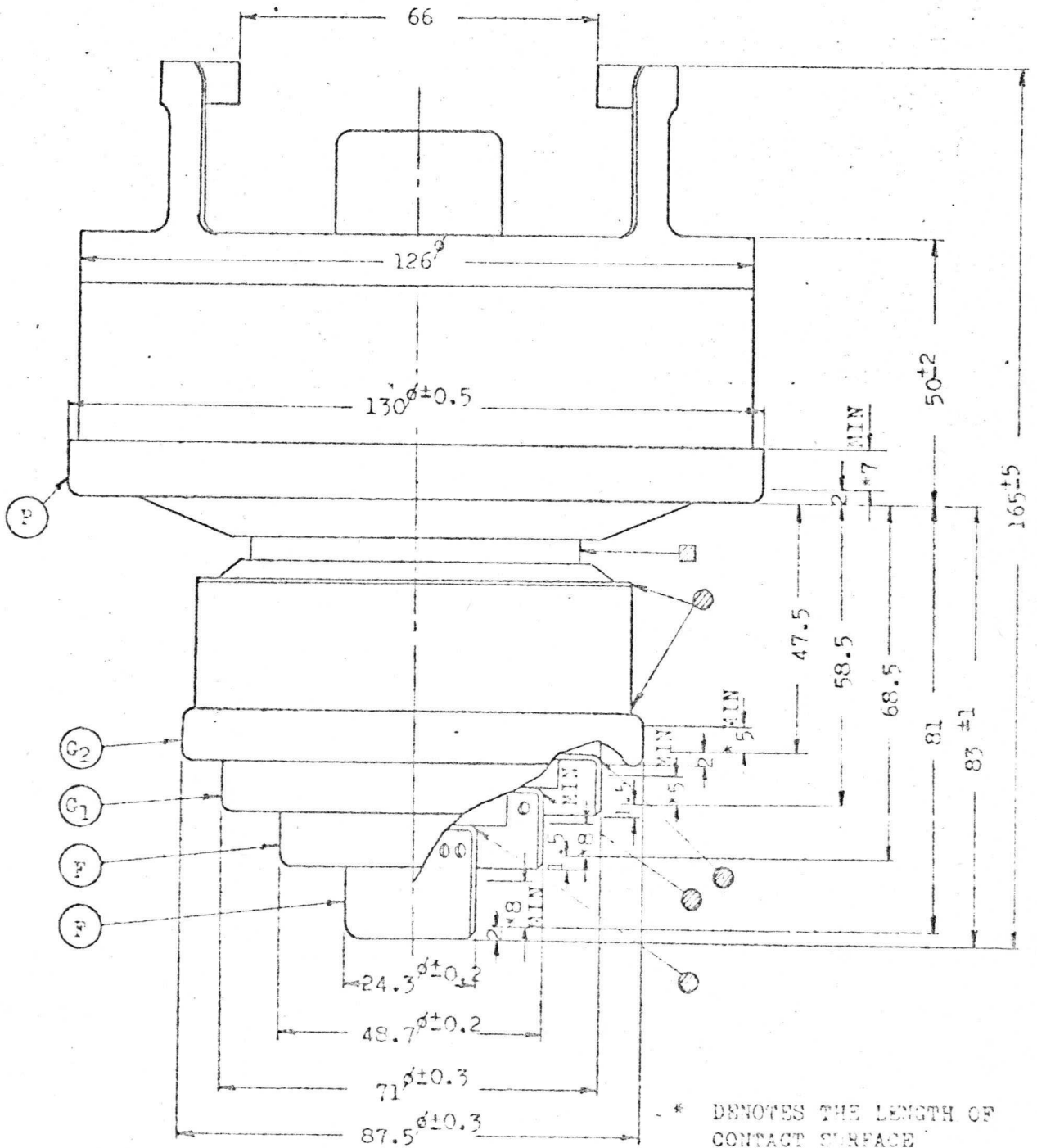

D.W.C.
ATTAR BROTHERS COMPANY ENGINEERING

Copy P.H.F.
P. DURHAM 9 JUL 1975

Messrs.
English Electric Valve Co. Ltd.,
Chelmsford
Essex
England.

DAMASCUS - SYRIA
P. O. BOX NO. 2771
TELEPHONES :
11 85 55 - 11 81 00

CABLES :
ATTARCO - DAMASCUS
ECSZ1
TELEX : 20023
ANSWER BACK : ATTARS

E940
S/R 100
CS13

Your Ref.

Your Letter dated

Our Ref. 4283/120

6th July 1975

Dear Sirs,

We have the pleasure to enclose herewith a photocopy of the technical information for "7F71RA " which is used for the Microwave Link project submitted by Messrs. Nippon Electric Company Ltd.

We ask you kindly to inform us the possibility of supplying an equivalent to the above, your final prices, and delivery time.

Thanking you in advance for your good collaboration, and hoping to hear you soon.

Yours sincerely,

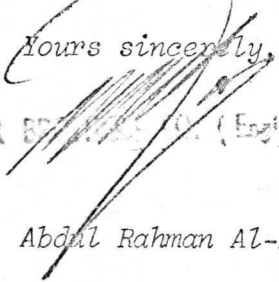
ATTAR BROTHERS (Engineering)

Abdul Rahman Al-Attar

Encl.

7F71RA

FORCED-AIR COOLED TETRODE

The NEC 7F71RA is a forced-air cooled tetrode designed for use as an amplifier in VHF-TV and FM transmitters. It features rugged coaxial ceramic-to-metal sealed construction suitable for cavity operation at high frequencies. The cathode consists of a mesh type thoriated tungsten filament.

The novel technique, including photoetching process, are used throughout the fabrication of the mesh type grids.

With these modern constructions and new techniques being employed, the NEC 7F71RA has high transconductance essential for high gain and high efficient operation and assures long life and highly reliable operation. The anode, with the integral radiator, is capable of dissipating 3.5 kilowatts of power with moderate rate of air flow.

Maximum ratings apply at frequencies up to 250 MHz.

ELECTRICAL DATA:-

GENERAL DATA:

Filament: Thoriated Tungsten

Voltage	4 volts <u>+5%</u>
Current	78 amps.
Maximum Starting Current	160 amps.
Minimum Heating Time	5 sec.
Transconductance (I _b =1.6 amps.)	70 millimohs
Amplification Factor, Grid No.2 to Grid No.1	11

INTERELECTRODE CAPACITANCES:

Grid No.1 to Plate	0.3 μ F
Filament to Plate	0.04 μ F
Grid No.1 to Filament	54 μ F
Grid No.1 to Grid No.2	95 μ F
Grid No.2 to Plate	13.5 μ F
Frequency for Maximum Ratings	250 MHz

MECHANICAL DATA

Dimensions:

Maximum Overall Length	165 mm
Maximum Diameter	130 mm
Net weight (approx.)	2.7 kg

Terminal Connections:

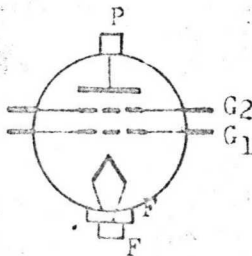

- P : Plate
- G² : Grid No.2
- G₁ : Grid No.1
- F : Filament

MOUNTING POSITION: Vertical, anode up or down

Cooling:

To Plate: Forced air cooling required

Minimum air flow	4.5 m ³ /min.
Minimum static pressure	45 mm of water

7F71RA

OUTLINE DRAWING
NEC 7F71RA

UNIT: mm

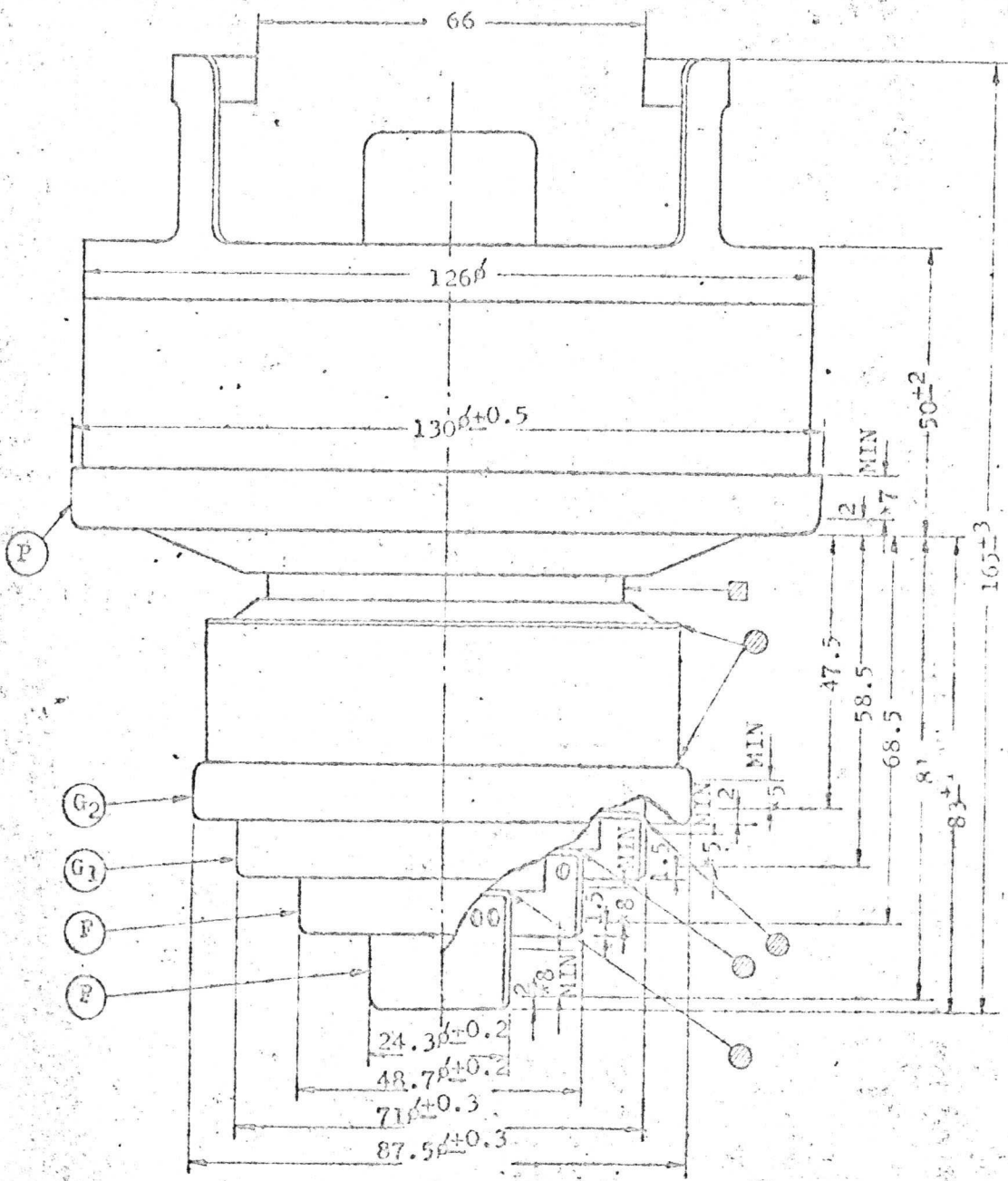

- * DENOTES THE LENGTH OF CONTACT SURFACE
- ☐ PLATE CORE TEMPERATURE MEASUREMENT POINT
- ⊙ SEAL TEMPERATURE MEASUREMENT POINT

Company, Ltd.

8/1

8 F 7 6 R

FORCED-AIR-COOLED TETRODE

The NEC 8F76R is a forced-air cooled tetrode designed specifically for use as an amplifier in VHF TV and FM equipment. The tube is also suitable in SSB linear amplifier application.

It features rugged coaxial ceramic-to-metal sealed construction suitable for cavity operation.

The cathode consists of a mesh type thoriated tungsten filament. The novel techniques, including electro-spark machining processes, are used throughout the fabrication of grid.

With these modern construction and new techniques being employed, the tube has high transconductance essential for high gain and high efficient operation and assures long life and highly reliable operation. The anode with its integral radiator can dissipate 15 kilowatts with moderate rate of air flow.

Maximum ratings apply at frequency up to 250 MHz.

ELECTRICAL DATA

GENERAL DATA:

Filament: Thoriated Tungsten

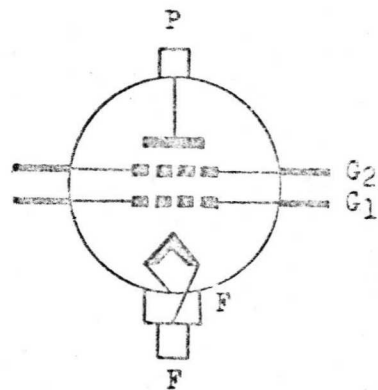
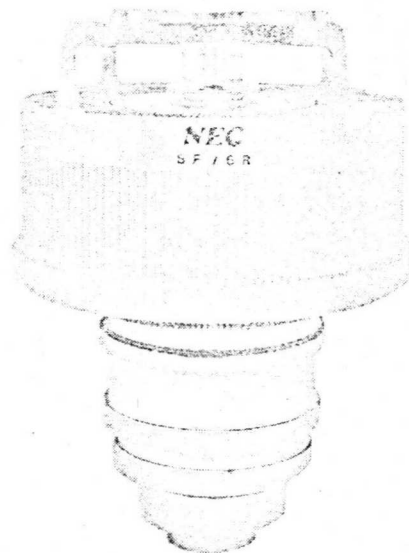

- P : Plate
- G₂ : Grid No.2
- G₁ : Grid No.1
- F : Filament

TERMINAL CONNECTIONS

Voltage	7.5	volts
Current	120	amps
Maximum Starting Current	300	amps
Minimum Heating Time	10	sec.
Transconductance (I _b =2.5 amps)	60	millimhos
Amplification Factor, Grid No.2 to Grid No.1	8.75	

Interelectrode Capacitances:

Grid No.1 to Filament	56	μμF
Grid No.1 to Grid No.2	91	μμF
Grid No.2 to Plate	20	μμF
Grid No. 1 to Plate (Note 1)	0.6	μμF
Plate to Filament (Note 1)	0.075	μμF

Note 1. Values measured with metal shield, 305 mm diameter having a central hole of 106 mm diameter, placed on the grid No.2 terminal plain and connected to it.

MECHANICAL DATA:

Dimensions:

Maximum Diameter	188.6	mm
Maximum Overall Length	257	mm
Net Weight (approx.)	9.4	kg

Mounting Position: Vertical, anode up or down

Cooling:

To plate: Forced air cooling required (Note 2)

Plate dissipation	10	12	15	kW
Minimum air flow	18	20	23	m ³ /min
Minimum static pressure	110	140	180	mm of water

To filament and grid seals:

Adequate forced-air flow should be delivered uniformly around the circumference of each seal to limit the temperature below the maximum rating (Note 2).

Maximum incoming air temperature	45 °C
Maximum radiator temperature (Note 3)	250 °C
Maximum filament and grid seal temperature	250 °C

Note 2. Start forced-air-flow to each portion of the tube prior to application of filament voltage. Continue air flow for about five minutes after removal of all voltages.

Note 3. Indicates the value measured at the point indicated by * sign in the outline drawing.

RF POWER AMPLIFIER-CLASS B TELEVISION

(Synchronizing peak level conditions per tube)

MAXIMUM RATINGS: Absolute Values

DC Plate Voltage	8000 volts
DC Grid No.2 Voltage	1500 volts
DC Grid No.1 Voltage	-1000 volts
DC Plate Current	5.5 amps
DC Grid No.2 Current	250 mA
DC Grid No.1 Current	250 mA
Plate Input	30 kW
Plate Dissipation	15 kW
Grid No.2 Dissipation	300 watts
Grid No.1 Dissipation	180 watts

TYPICAL OPERATION: (in cathode drive circuit)

DC Plate Voltage	6200 volts
DC Grid No.2 Voltage	880 volts

DC Grid No.1 Voltage	-120 volts
Peak RF Grid No.1 to Cathode Voltage	
Synchronizing peak level	155 volts
Pedestal level	128 volts
DC Plate Current	
Synchronizing peak level	3.5 amps
Pedestal level	2.6 amps
DC Grid No.2 Current	
Synchronizing peak level	27 mA
Pedestal level	0 mA
DC Grid No.1 Current	
Synchronizing peak level	46 mA
Pedestal level	0 mA
Driving Power (approx.) (Note 4)	
Synchronizing peak level	455 watts
Pedestal level	270 watts
Plate Power Output (approx.)	
Synchronizing peak level	13.4 kW
Pedestal level	7.55 kW

RF LINEAR AMPLIFIER-CLASS A B₁

(SSB suppressed - carrier operation, single tone modulation conditions per tube)

MAXIMUM RATING: Absolute Values

DC Plate Voltage	8000 volts
DC Grid No.2 Voltage	1500 volts
Max. Signal DC Plate Current	5.5 amps

Plate Dissipation	15 kW
Grid No.2 Dissipation	300 watts

TYPICAL OPERATION: (in grid drive circuit)

DC Plate Voltage	8000 volts
DC Grid No.2 Voltage	1000 volts
DC Grid No.1 Voltage	-130 volts
Peak RF Grid No.1 Voltage	120 volts
Max. Signal DC Plate Current	2.16 amps
Zero-Signal DC Plate Current	250 mA
Max. Signal DC Grid No.2 Current	30 mA
Max. Signal Driving Power (approx.) (Note 4)	0 watts
Max. Signal Power Output (approx.)	11.4 kW

RF POWER AMPLIFIER AND OSCILLATOR-CLASS C TELEGRAPHY AND FM TELEPHONY

(Key down conditions per tube without modulation)

MAXIMUM RATINGS: Absolute Values

DC Plate Voltage	8000 volts
DC Grid No.2 Voltage	1500 volts
DC Grid No.1 Voltage	-1000 volts
DC Plate Current	4.5 amps
DC Grid No.2 Current	250 mA
DC Grid No.1 Current	250 mA
Plate Input	30 kW
Plate Dissipation	15 kW
Grid No.2 Dissipation	300 watts
Grid No.1 Dissipation	180 watts

TYPICAL OPERATION: (in grid drive circuit)

DC Plate Voltage	7000	volts
DC Grid No.2 Voltage	1000	volts
DC Grid No.1 Voltage	-260	volts
Peak RF Grid No.1 Voltage	312	volts
DC Plate Current	3	amps
DC Grid No.2 Current	63	mA
DC Grid No.1 Current	67	mA
Driving Power (approx.) (Note 4)	20	watts
Plate Power Output (approx.)	15.4	kW

Note 4. These values do not include circuit losses.

APPLICATION INSTRUCTIONS

1. INITIAL INSPECTION

When NEC 8F76R is received, it should be unpacked and inspected as soon as possible. In handling the 8F76R, extreme care should be taken to protect the tube from undue shock and vibration since the thoriated-tungsten filament, the ceramic-to-metal seals or other intricate tube parts may easily be damaged. It is to be noted that the tube should be carried only by the handles provided at the top of radiator.

A careful inspection should be made for any visible damage, such as cracked ceramic or deformed metal parts which may have occurred during the transit. The tube should then be checked with an ohmmeter to determine if interelectrode short-circuit or open-filament has occurred.

If no failure is assured by the above-mentioned inspection, the tube should be installed in the equipment and all electrical connections made. Rated filament voltage should be applied and the filament current checked to see if it agrees with the value indicated on the data

sheet attached to the tube. When the filament voltage and current measurements are performed, measurement should be made a few minutes after the application of filament voltage and the values have been stabilized. Care should be taken to calibrate the voltmeter and ammeter accurately, and to connect the voltmeter directly across the filament terminal so as to prevent the error caused by the voltage drop of filament leads and socket carrying a heavy current.

If there is any evidence of damage in transit, report should be prepared and mailed to the Sales Department, Electron Device Division of NEC, within fifteen days. The serial number identifying each individual tube appears on the top surface of anode.

2. OPERATION

When the tube is being fixed to the cavity, the ceramic envelope and other external portions of the 8F76R should be kept free from accumulated dust to minimize surface leakage and the possibility of arc-over. It is recommended that dust be wiped with clean soft cloth.

The ceramic surface should never come in contact with metallic pieces such as metal tools, because the contact will leave some metallic traces which may impair the insulating property of the ceramic surface. For the same reason, writing on the surface with lead pencil is prohibited.

If dusts are adhered to the cavity, it should be removed and check if deformation, loss or wear of contact finger, which will be a cause of imperfect contact, exists in the socket. When the tube is inserted into the socket, it should be pushed carefully with its axis being right on the axis of the socket. If it is felt tight, never force it. Check the concentricity of all contact surface of the socket.

After filament and grid No.1 voltage supplies have been on for two to three minutes, apply minimum plate and grid No.2 voltages or if plate and grid No.2 voltage cannot be reduced, reduce driving power and operate the tube at approximately half the normal plate input level for half an hour. All tuning adjustment should be made during this period.

Normal plate and grid No.2 voltages and plate input may then be applied and final tune-up performed. The tube should be run at normal voltages and driving power for at least additional half an hour.

3. TUBE PROTECTION

All protective circuits and interlocks such as over-current relay, air interlocks etc. to remove power in fault condition should be checked regularly in order to assure their proper functioning.

Fault over-load, due to circuit or tube instability may result in the following conditions.

- 1 liberation of gas in the tube
- 2 gross damage to internal element, e.g. burn-out of grid wires
- 3 external arcing-over between electrode terminals with damage to seals

A tube which became gassy can often be cleaned up successfully by the patient reaging process according to the schedule described in the preceding paragraph. The other conditions listed above are usually catastrophic.

4. TUBE CARE

The ceramic envelope and other external portions of the 8F76R should be kept free from accumulated dust to minimize surface leakage and the possibility of arc-over. All tube terminals and connectors must be kept bright and clean to provide good electrical contact. The tube should be stored in its shipping container and should be protected from moisture, extreme temperature variation and undue shock and vibration. In handling, transit and storage the tube should always be held vertically with its anode down.

When packing the NEC 8F76R for reshipment, it should be packed as in the initial shipment. The tube Return Authorization Sheet supplied

with each tube should be filled out and forward, whenever the tube is to be returned to the factory.

EQUIPMENT DESIGN CONSIDERATION

1. MAXIMUM RATINGS AND TYPICAL OPERATING CONDITIONS

Maximum ratings given either for electrical or for mechanical items in the tabulated data are limiting values above which, if exceeded, serviceability of any individual tube may be impaired. Maximum rating applies independently on each item and does not form a set of satisfactory operating conditions. When designing circuitry, therefore, it is necessary to insure that the maximum ratings will never be exceeded under any conditions, even momentarily.

The typical operating conditions, given in the tabulated data do not include the circuit losses, hence, useful power output to the load will be less than that indicated, depending on the frequency of operation and circuit efficiency.

2. COOLING SYSTEM

The cooling system is required to provide sufficient clean air flow through the radiator and to the filament terminals. A suitable air-filter should be provided in the air supply system. Care should be given for cleaning or replacing the filter at intervals in order that accumulated dust will not obstruct the flow of air. The required static pressure versus air flow characteristic of the radiator of the NEC 8F76R is shown in the attached figure. Allowance for pressure drops in an air filter, ducts and louvers etc., should be made in selecting a blower. It is also necessary to provide enough margin in air flow to take care of the increase of friction loss in the duct and the decrease of blower efficiency after prolonged operation. Since the cooler operation of the tube prolongs tube life markedly, adequate margin in air flow should be provided. Without air flow, the tube is easily damaged by the application of filament power alone.

Therefore, the cooling system should be electrically interlocked with the filament and other power supplies. The arrangement is

necessary to make sure that the tube is supplied with air before any voltage is applied. The filament, grid No.2, plate power supplies and air flow may be shut down simultaneously but as a good practice it is recommended to supply air flow for about three minutes after removal of all voltages.

The temperature of the radiator and each electrode seal must not exceed their maximum ratings of 250 °C, like other electrical maximum ratings. Temperature at various parts of the tube may be measured by using thermosensitive paint like "tempilaq".

3. ELECTRICAL CONSIDERATION

Filament Voltage

The cathode of the NEC 8F76R is of the mesh type thoriated-tungsten filament. Since the life of the tube can be prolonged markedly by operating it at the lowest voltage which will enable the tube to give satisfactory performance, it is range of 10 percent down from nominal value. The filament should never be operated, under any circumstances, at higher, by 5 percent of rated value, than nominal voltage.

MONITORING OF OPERATION

Suitable meters should be provided for monitoring filament voltage, dc plate voltage, plate current, dc grid No.2 voltage, grid No.2 current, dc grid No.1 voltage and grid No.1 current. Elapsed-time meter should be installed to read total hours of filament operation. Active material evaporates from the filament even when the filament voltage alone is applied. Therefore tube life should be counted by total hours of filament operation.

GRID NO.1 BIAS

In class-A B and B RF linear amplifier service, the 8F76R should be operated with grid No.1 bias obtained from fixed dc source of good voltage regulation. If tubes are used in parallel or in push-pull, the grid circuit of each tube should be provided with a separated bias

adjustment to balance the grid and plate current. The zero-signal plate current has a critical influence on the linearity and usually it is chosen for the best compromise between zero signal plate dissipation and distortion. Therefore the grid circuit should be designed with a fine bias adjustment. In class-C RF telegraphy service, the grid No.1 bias may be obtained either from a grid resistor, combination of grid resistor and a fixed supply or combination of grid and cathode resistor. The latter two methods have an advantage of protecting of the tube from damage through loss of driving power.

GRID NO.2 VOLTAGE

Protection against the over-loading of grid No.2 should be provided by an over-current relay and by interlocking the grid No.2 supply so that plate voltage must be applied before grid No.2 voltage is applied. Variation of load impedance causes variations of plate and grid No.2 current. Light load increases grid No.2 current while decreasing plate current and results in excessive grid No.2 dissipation. Heavy load tend to increase plate current and decrease grid No.2 current which results in lower efficiency and excessive plate dissipation.

The grid No.2 current may reverse under certain conditions and produce negative current indications on the grid No.2 ammeter. This is a normal characteristic of most tetrodes. Therefore, a current path from grid No.2 to cathode must be provided by a bleeder resistor, and is arranged to pass an adequate bleeder current per connected grid No.2.

In the usual tetrode amplifier, where no signal voltage appears between cathode and grid No.2, grid No.2 dissipation is equal to the product of the dc grid No.2 voltage and the dc grid No.2 current. When signal voltage appears between grid No.2 and cathode, as in the case of cathode-driven amplifier, grid No.2 dissipation may become much more than the value obtained in the aforementioned case. In the case of class-A B or class B RF linear power amplifier, care should be taken to prevent the increase of distortion caused by variation of grid No.2 voltage.

4. FAULT PROTECTION

The handling of high power requires particular attention to the

removal of power under fault conditions, since the large amount of energy involved can cause severe damage to the tube or to the equipment, if not properly controlled.

The ground lead of the plate circuit of each tube should be connected in series with the coil of quick acting over-load relay, adjusted to open the circuit breakers in primary of rectifier transformer at slightly higher than normal operating plate current. The total response time required for the operation of relay and circuit breakers should be 1/10 of a second or less.

As mentioned before, the grid No.2 circuit should also be equipped with similar over-load relay.

The above mentioned discussion presents information necessary to obtain satisfactory and economical performance of the NEC 8F76R under normal operating conditions. For information concerning specific tube problem or application not covered here, consult the Engineering Department, Electron Device Division, Nippon Electric Company Ltd., 1753 Shimo-numabe, Kawasaki City, Japan.

CONSTANT CURRENT CHARACTERISTICS

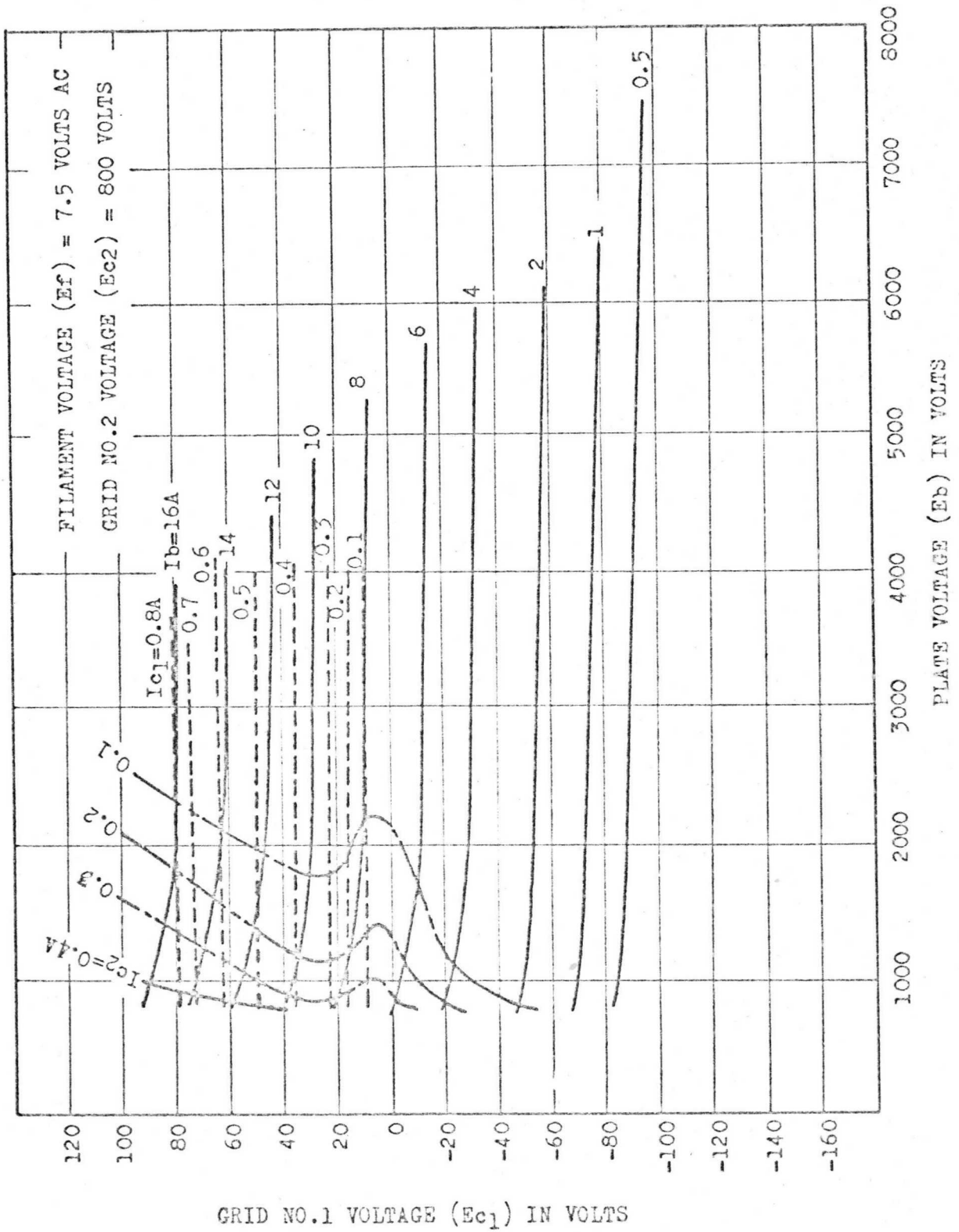

CONSTANT CURRENT CHARACTERISTICS

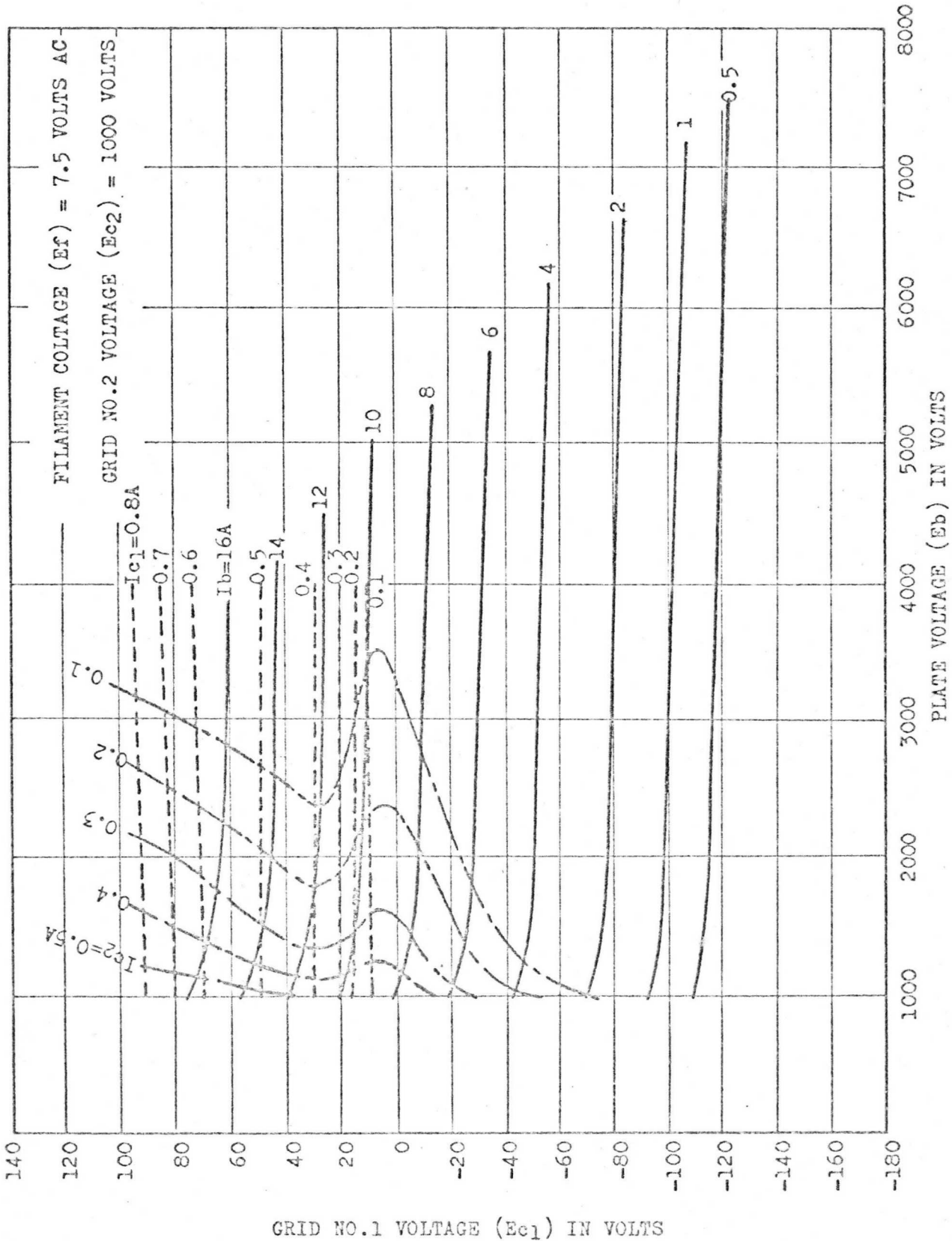

CONSTANT CURRENT CHARACTERISTICS

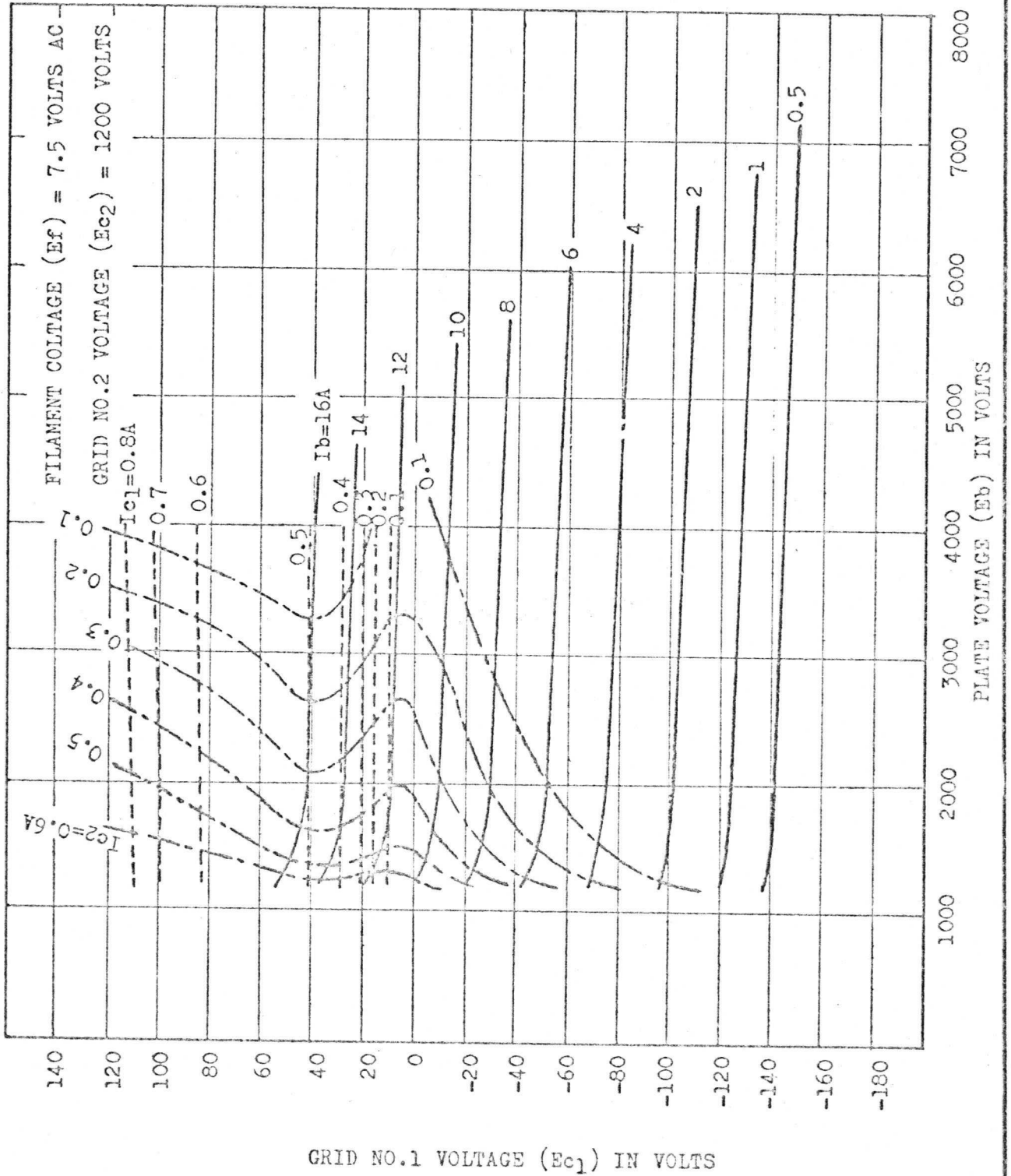

CONSTANT CURRENT CHARACTERISTICS

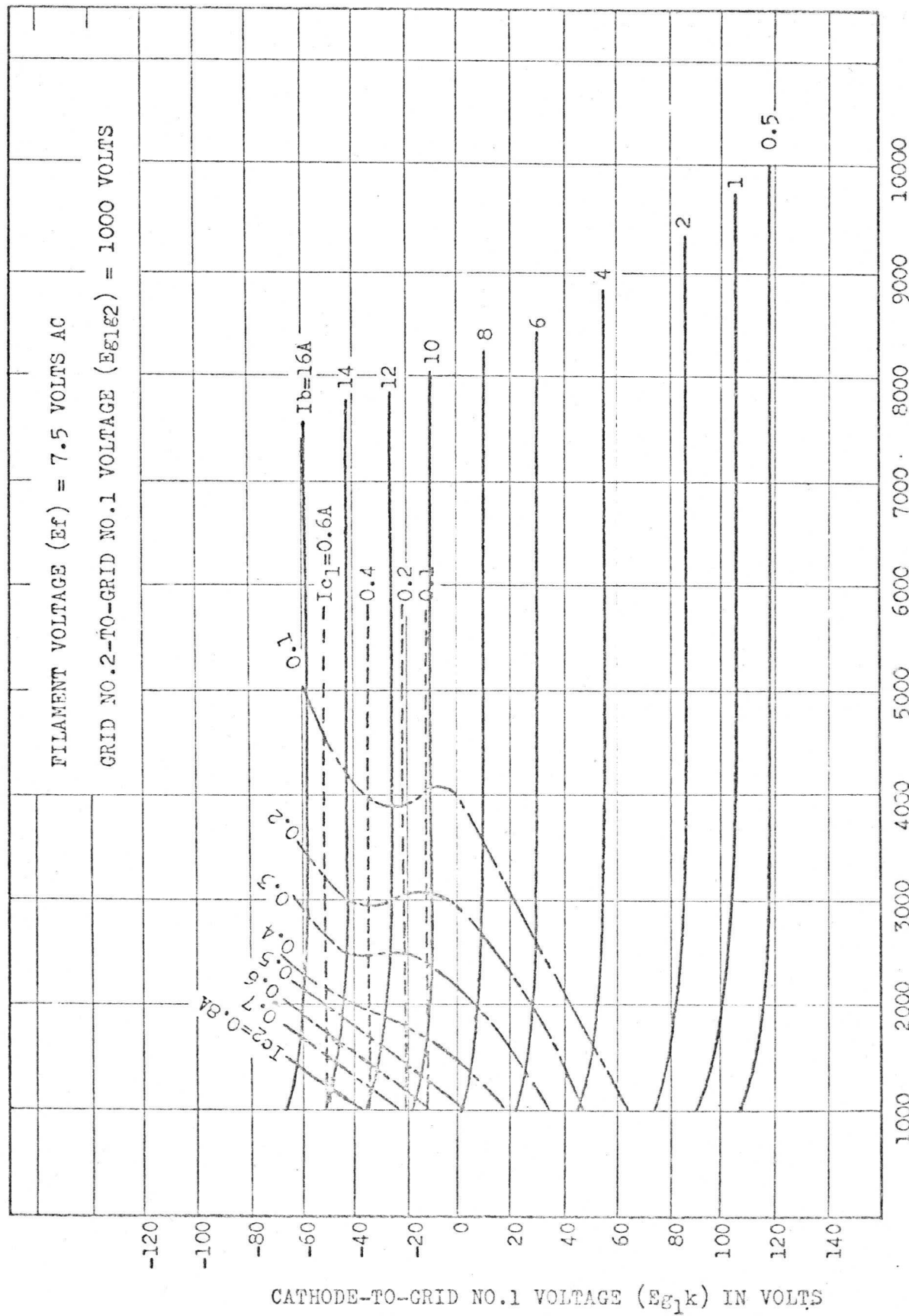

AIR COOLING CHARACTERISTICS

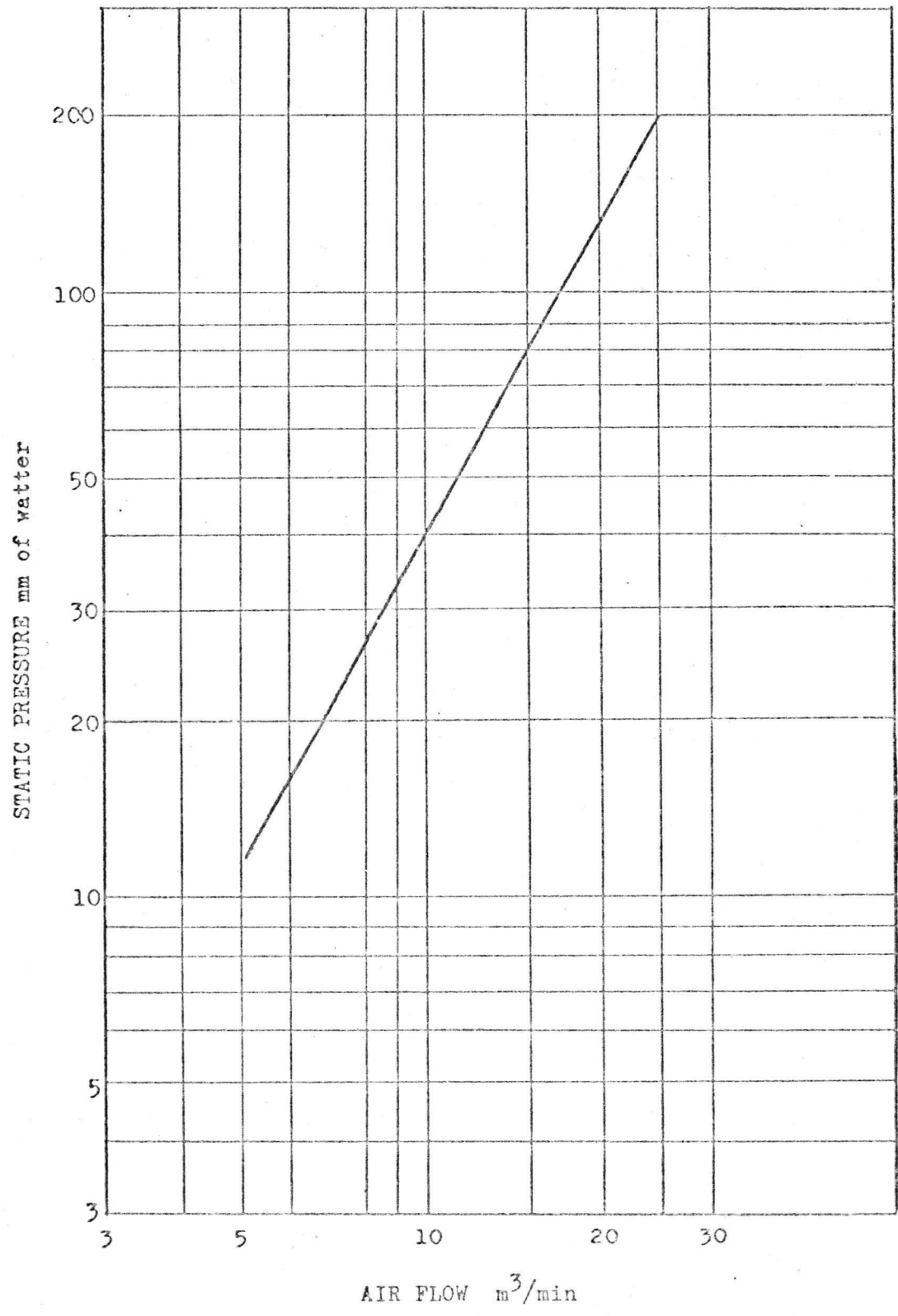

OUTLINE DRAWING

(Unit in mm)

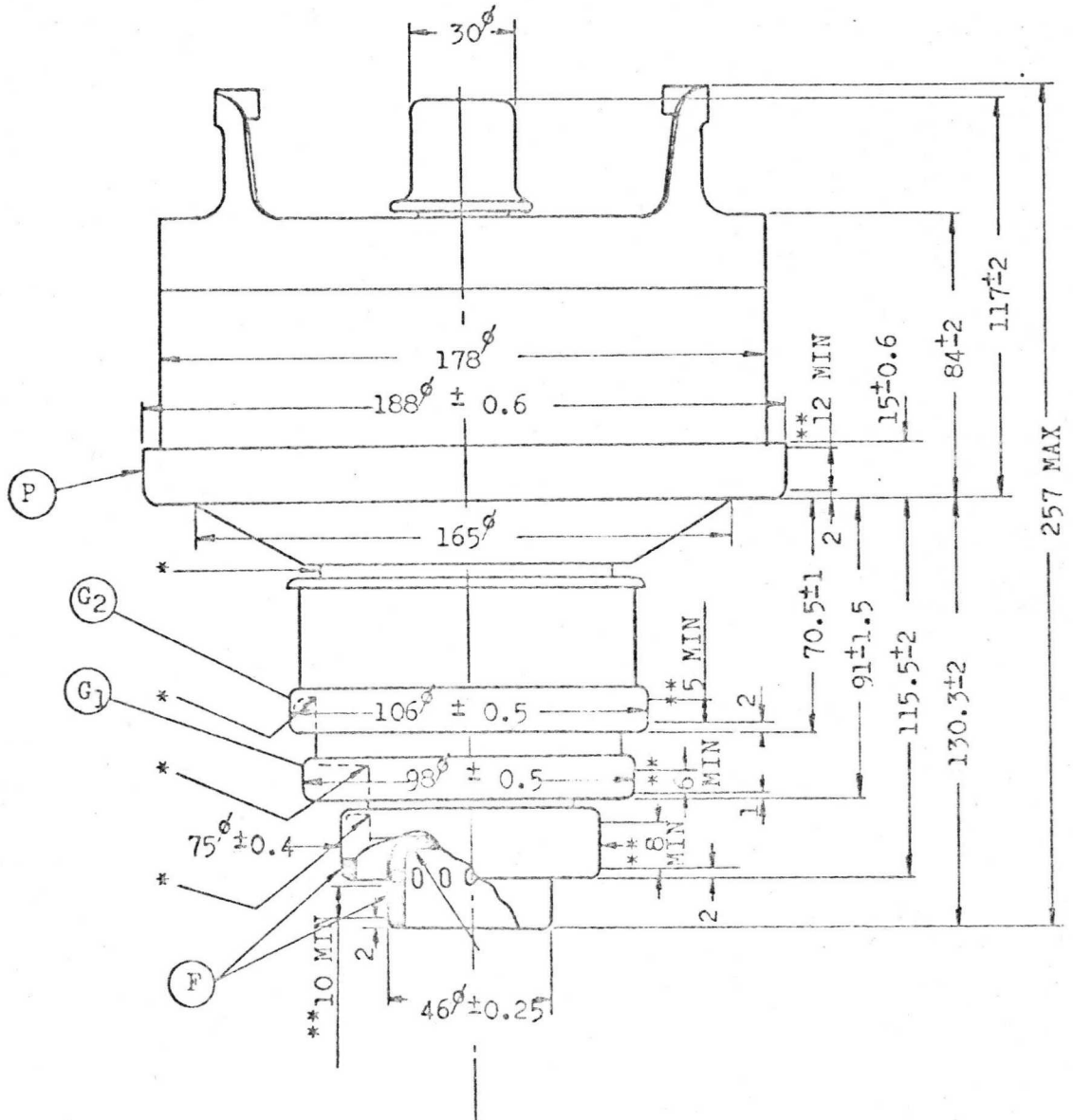

** CONTACT SURFACE

8T39

Vapour Cooled Triode

The NEC 8T39 is a vapour cooled triode with a maximum plate dissipation rating of 10 kW. The tube is a vapour cooled version of the NEC 8T33, water cooled triode. Electrical characteristics of the NEC 8T39 are similar with those of the 8T33.

Due to its high transconductance, high output with high efficiency is easily obtainable at relatively low plate voltage. The ring-sealed grid terminal provides a low lead inductance which assures stable operation at high frequencies. The tube is designed for use as an amplifier, modulator or oscillator in AM broadcast transmitter and in industrial heating services. Maximum ratings apply at frequencies up to 30 Mc/s.

Electrical Data:

General Data:

Filament: Thoriated Tungsten

Voltage	7.5 volts
Current	60 amps
Maximum Starting Current	120 amps
Minimum Heating Time	5 sec
(Time interval between the instant of application of filament voltage and that of plate voltage)	
Transconductance	18 millimhos
(at $E_b=5000$ volts, $I_b=1.0$ amp)	
Amplification Factor	40
Direct Interelectrode Capacitances:	
Grid to Plate	26 μ F
Grid to Filament	49 μ F
Plate to Filament	3.7 μ F

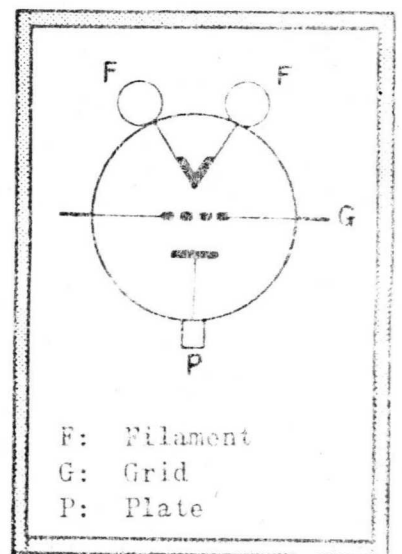
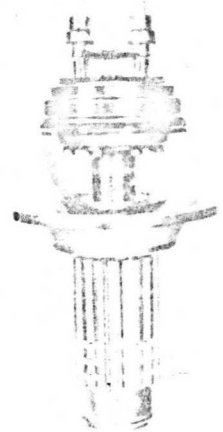

TERMINAL CONNECTIONS

Mechanical Data:

Dimensions:

Maximum Diameter	162 mm
Maximum Overall Length	375 mm
Net Weight (approx.)	3.5 kg
Mounting Position: Vertical, anode down	

Cooling:

To plate: vapour-cooling required	
To stem and glass bulb: forced-air flow required (Note 1, 3)	
Minimum air flow (Note 2)	0.4 m ³ /min
Maximum bulb temperature	180°C
Maximum seal temperature	180°C

Accessories Required:

Boiler	NEC VB506
Vapour condenser	NEC VB602
Water level controller	NEC VB550
Insulator pipe (steam outlet)	NEC VB704
Insulator pipe (condensed water inlet)	NEC VB701
Pressure equalizer	NEC VB752
Rubber joint between steam piping and insulator pipe	NEC VB782
L-joint between insulator pipe (condensed water inlet) and boiler	NEC VB740
Joint between insulator pipe (condensed water inlet) and copper tube ..	NEC VB742
Adapter for steam inlet of condenser	NEC VB762
Adapter for condensed water outlet of condenser	NEC VB766
Adapter for drain valve	NEC VB746
Gasket for steam outlet of boiler	NEC VB773
Gasket for condensed water inlet of boiler	NEC VB770
Steam piping	2 inch, type M copper tube
Condensed water piping	3/4 inch, type M copper tube
Filament connector (2 required)	NEC VT403
Grid connector	NEC VT305

Note 1. The specified air flow should be directed vertically from a nozzle of approx. 35 mm diameter into center of the filament terminals.

Note 2. Adequate forced-air flow is required to limit the temperature of the seals and bulb below their specified maximum values.

The amount of air-flow required will increase with the operating frequency.

Note 3. Start forced-air flow for each portion of the tube prior to the application of filament voltage.

Continue air flow at least 3 minutes after removal of all voltages.

AF Power Amplifier and Modulator-Class B

Maximum Ratings: Absolute Values

DC Plate Voltage	10000 volts
Max. Signal DC Plate Current (Note 4)	2.5 amps
Max. Signal Plate Input (Note 4)	25 kW
Plate Dissipation (Note 4)	10 kW

Typical Operation: (Values are for two tubes)

DC Plate Voltage	5000	8000 volts
DC Grid Voltage	-115	-200 volts
Peak AF Grid-to-Grid Voltage	600	900 volts
Zero Signal DC Plate Current	0.2	0.2 amps
Max. Signal DC Plate Current	2.7	4 amps
Max. Signal DC Grid Current	160	240 milliamps
Effective Load Resistance, Plate to Plate	3500	4200 ohms
Max. Signal Driving Power (approx.)	45	100 W
Max. Signal Power Output (approx.)	8	22 kW

Note 4. Averaged over any audio-frequency cycle of sine-wave form.

Plate-Modulated RF Power Amplifier-Class C Telephony

(Carrier Conditions per tube for use with maximum modulation factor of 1.0)

Maximum Ratings: Absolute Values

DC Plate Voltage	7500 volts
DC Grid Voltage	-1000 volts
DC Plate Current	2 amps
DC Grid Current	0.4 amps
Plate Input	15 kW
Plate Dissipation	6.6 kW
Grid Dissipation	250 W

Typical Operation:

DC Plate Voltage	5000 volts
DC Grid Voltage	-400 volts
DC Plate Current	1.55 amp.
DC Grid Current (approx.)	0.33 amps
Peak RF Grid Voltage	730 volts
Driving Power (approx.)	220 watts
Power Output (approx.)	6 kW

RF Power Amplifier and Oscillator-Class C Telegraphy

(Key-down conditions per tube without amplitude modulation)

Maximum Ratings: Absolute Values

DC Plate Voltage	10000 volts
DC Grid Voltage	-1000 volts
DC Plate Current	2.7 amps
DC Grid Current	0.4 amps
Plate Input	27 kW
Plate Dissipation	10 kW
Grid Dissipation	250 watts

Typical Operation:

DC Plate Voltage	5000	9000 volts
DC Grid Voltage	-300	-500 volts
Peak RF Grid Voltage	630	900 volts
DC Plate Current	1.8	2.5 amps
DC Grid Current (approx.)	0.3	0.3 amps
Driving Power (approx.)	170	250 watts
Power Output (approx.)	6	17 kW

CONSTANT CURRENT CHARACTERISTICS

NEC 8T39

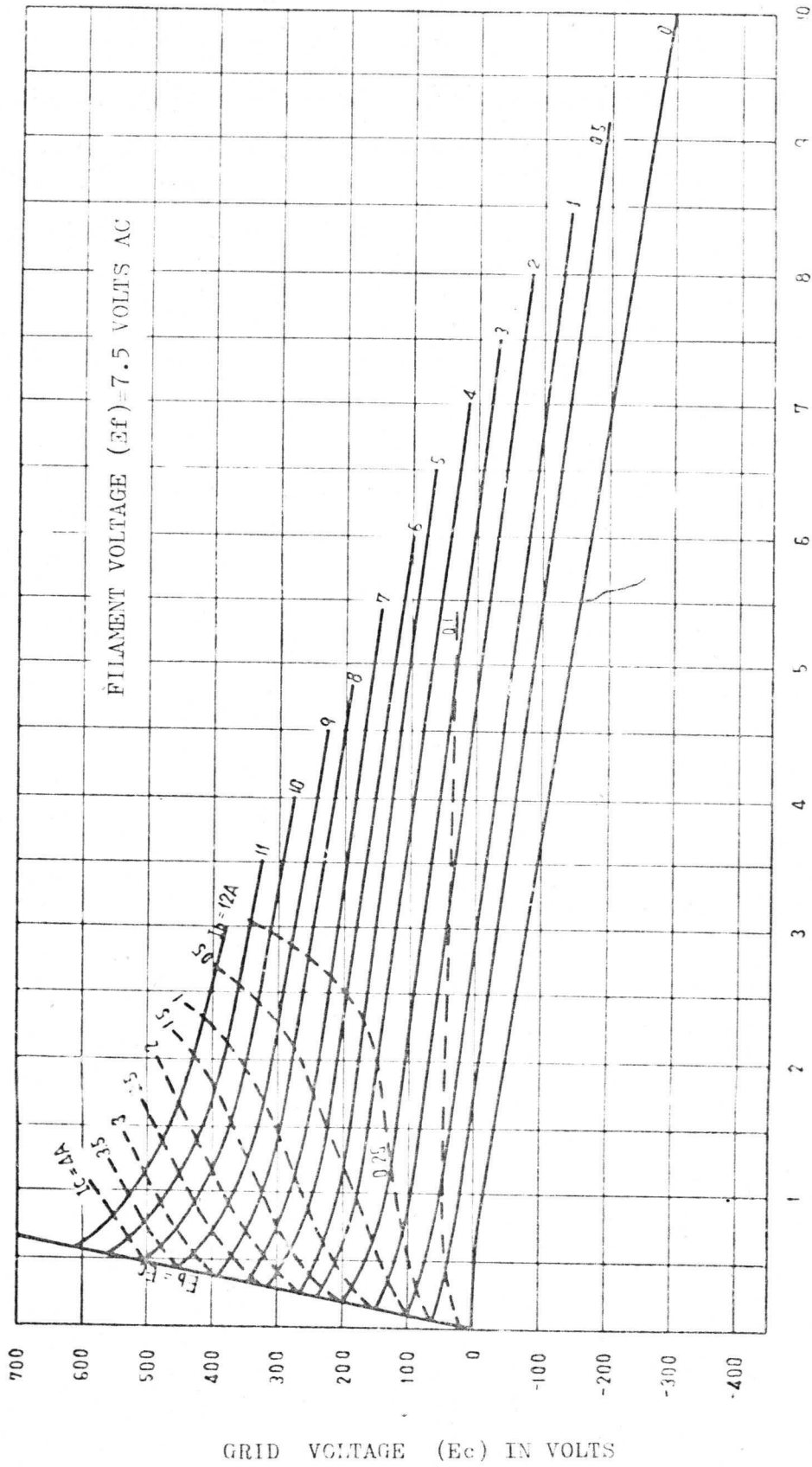

PLATE VOLTAGE (E_b) IN KILOVOLTS

8T39

OUTLINE DRAWING

NEC 8T39

UNIT: mm

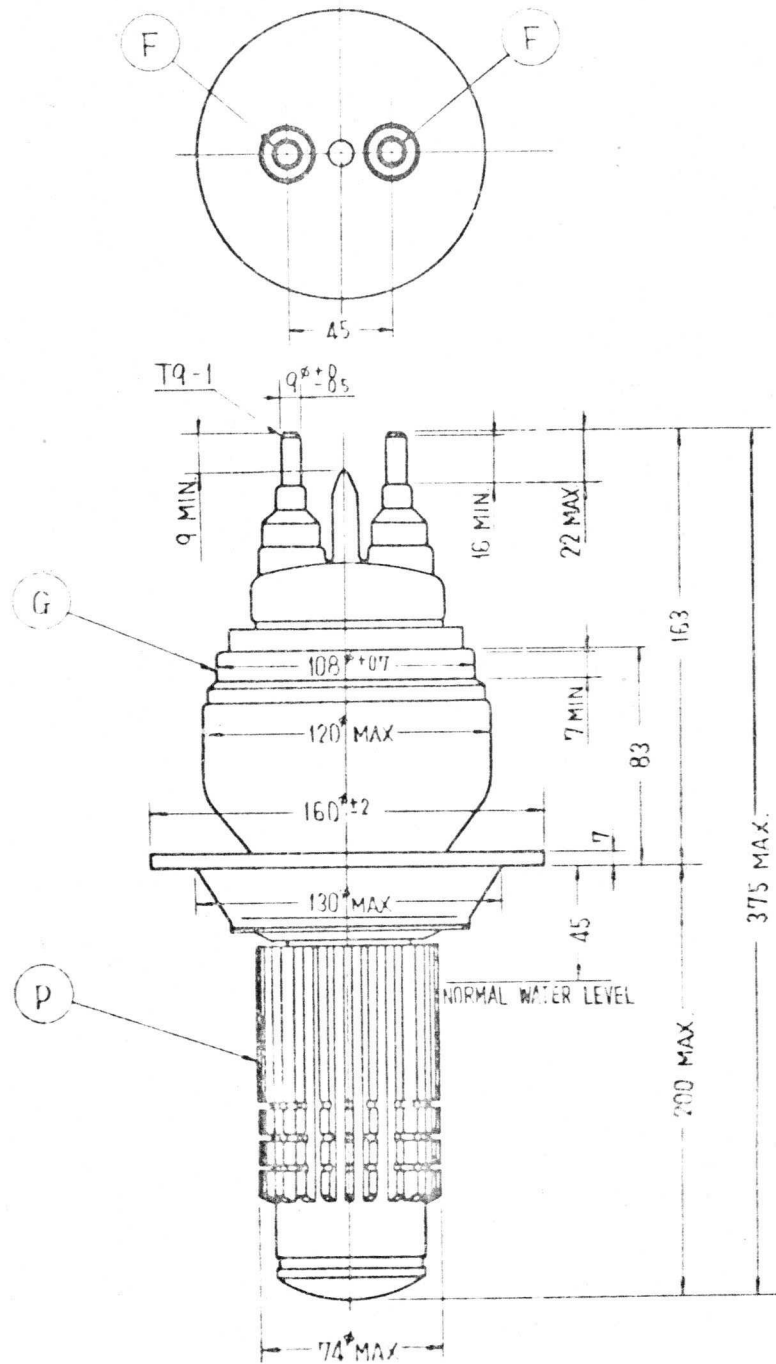

Nippon Electric Company Limited

P.O. Box 1, Takahama, Tokyo, Japan
Cable Address: MICROPHONE TOKYO

May 1967
Printed in Japan

9 T 4 0

Vapour Cooled Triode

The NEC 9T40 is a high power vapour cooled triode designed for use as an amplifier, modulator and oscillator in medium and short wave frequency broadcast transmitter and in industrial heating services.

The tube features rugged coaxial construction and its ring-sealed terminals provide low lead inductances which assures stable operation at high frequencies.

The cathode consists of multistrand, thoriated-tungsten filaments, completely balanced and stress free throughout life.

Electrical characteristics of the NEC 9T40 are similar with those of the 9T38, except than the anode dissipation rating is increased to 150 KW.

Maximum ratings of plate voltage and input apply at frequencies up to 2 MHz/s.

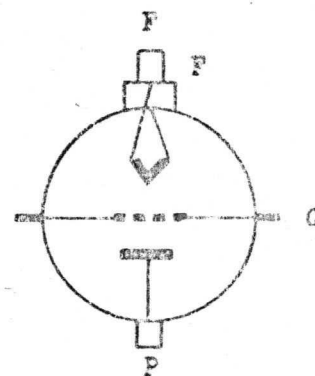

F: Filament
G: Grid
P: Plate

TERMINAL CONNECTIONS

ELECTRICAL DATA

GENERAL DATA

Filament : Thoriated tungsten

Voltage	18 volts
Current	315 amps.

Maximum Starting Current	1000	amps.
Transconductance (at $I_b=5$ amps.)	80	milli-mhos
Amplification Factor	40	

Direct Interelectrode Capacitances :

Grid to Plate	100	μF
Grid to Filament	180	μF
Plate to Filament	3	μF

MECHANICAL DATA

Dimension :

Maximum Diameter	360	mm
Maximum Overall Length	745	mm
Net Weight (approx.)	53	kg

Mounting Position : Vertical, anode down

Cooling :

To plate : Vapour-cooling required

To stem and glass bulb : Forced-air-flow required (Note 1, 2)

Minimum air flow	5	$m^3/min.$
Maximum glass temperature	180	°C
Maximum seal temperature	165	°C

Accessories Required :

Filament connector	NEC VT-326
Filament connector	NEC VT-327

Note 1. The specified air flow should be directed vertically from a nozzle of approx. 70 mm diameter into the center of stem.

Note 2. Start forced-air-flow for each portion of the tube prior to the application of filament voltage. Continue air flow at least 3 minutes after removal of all voltages.

AF POWER AMPLIFIER AND MODULATOR-CLASS B

MAXIMUM RATINGS : Absolute Values

DC Plate Voltage	15000	volts
Max.-Signal DC Plate Current (Note 3)	18	amps.
Max.-Signal Plate Input (Note 3)	270	kW
Plate Dissipation (Note 3)	150	kW

TYPICAL OPERATION : Values are for two tubes

DC Plate Voltage	12000	14000	volts
DC Grid Voltage	-300	-340	volts
Peak AF Plate to Plate Voltage	19200	22400	volts
Zero-Signal DC Plate Current	2	2	amps.
Max.-Signal DC Plate Current	32	30	amps.
Max.-Signal DC Grid Current	1.72	1.24	amps.
Effective Load Resistance, Plate to Plate	784	896	ohms
Max.-Signal Driving Power (approx.)	572	390	watts
Max.-Signal Power Output (approx.)	234	273	kW

Note 3. Averaged over any audio-frequency cycle of sine-wave form.

PLATE-MODULATED RF POWER AMPLIFIER-CLASS C TELEPHONY

(Carrier conditions per tube for use with a maximum modulation factor of 1.0)

MAXIMUM RATINGS : Absolute Values

DC Plate Voltage	12000	volts
DC Grid Voltage	-1500	volts
DC Plate Current	16	amps.
DC Grid Current	4.5	amps.
Plate Input	190	kW
Plate Dissipation	100	kW
Grid Dissipation	2.5	kW

TYPICAL OPERATION :

DC Plate Voltage	10000	10000	12000	volts
DC Grid Voltage	-530	-530	-720	volts
Peak RF Grid Voltage	980	1010	1300	volts
DC Plate Current	10.4	13	14.5	amps.
DC Grid Current (approx.)	2.3	3	3.8	amps.
Power Output (approx.)	85.2	104	150	kW

RF POWER AMPLIFIER AND OSCILLATOR-CLASS C TELEGRAPHY

(Key-down conditions per tube without amplitude modulation)

MAXIMUM RATINGS : Absolute Values

DC Plate Voltage	15000	volts
DC Grid Voltage	-1500	volts
DC Plate Current	20	amps.
DC Grid Current	4.5	amps.
Plate Input	300	kW
Plate Dissipation	120	kW

Grid Dissipation 2.5 kW

TYPICAL OPERATION :

DC Plate Voltage	12000	15000	volts
DC Grid Voltage	-1200	-1200	volts
(From a grid resistor of)	400	400	ohms
Peak RF Grid Voltage	1830	1830	volts
DC Plate Current	18	20	amps.
DC Grid Current	3	3	amps.
Driving Power (approx.)	5	5.1	kW
Power Output (approx.)	177	233	kW

CONSTANT CURRENT CHARACTERISTICS

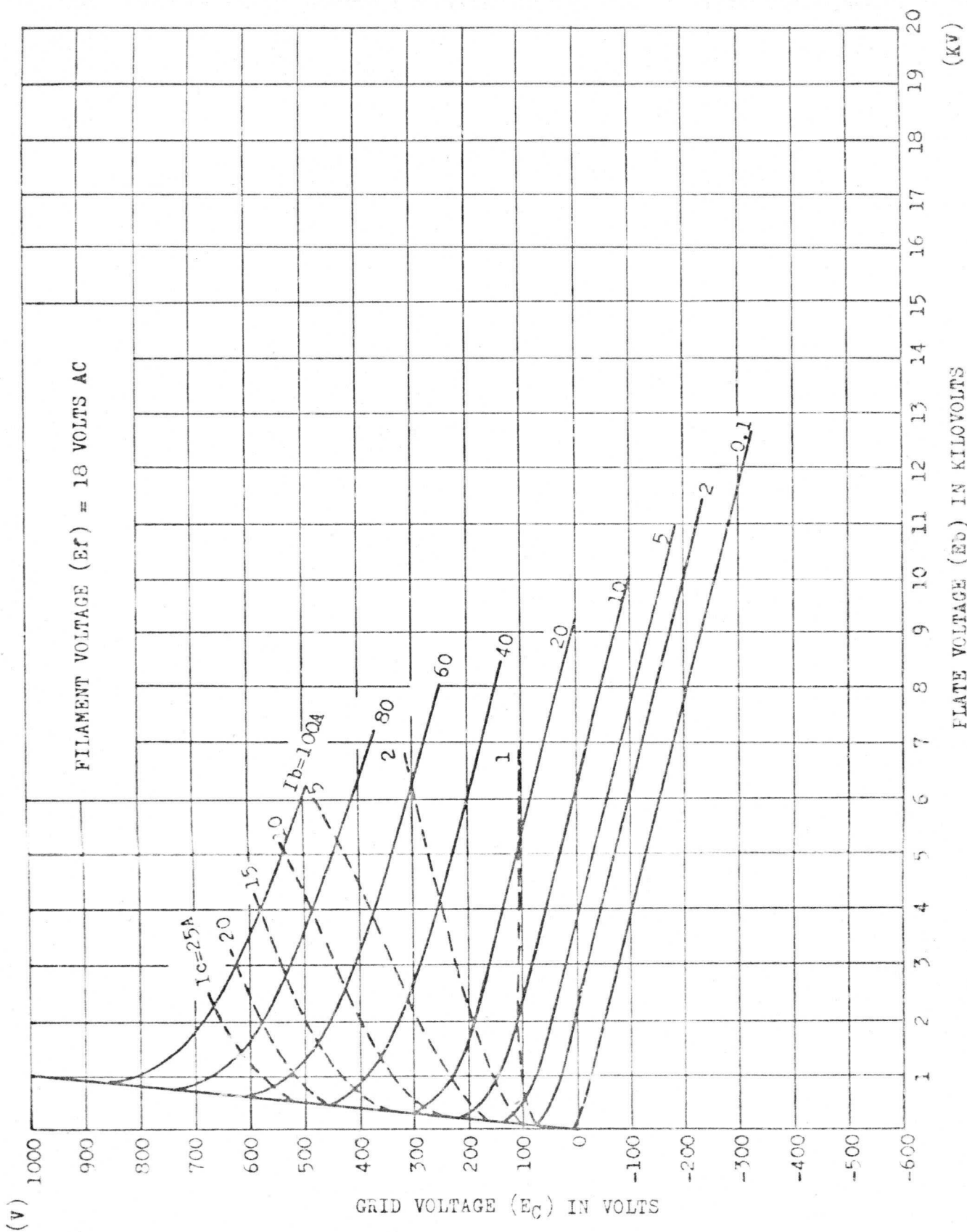

OUTLINE DRAWING

(Unit in mm)

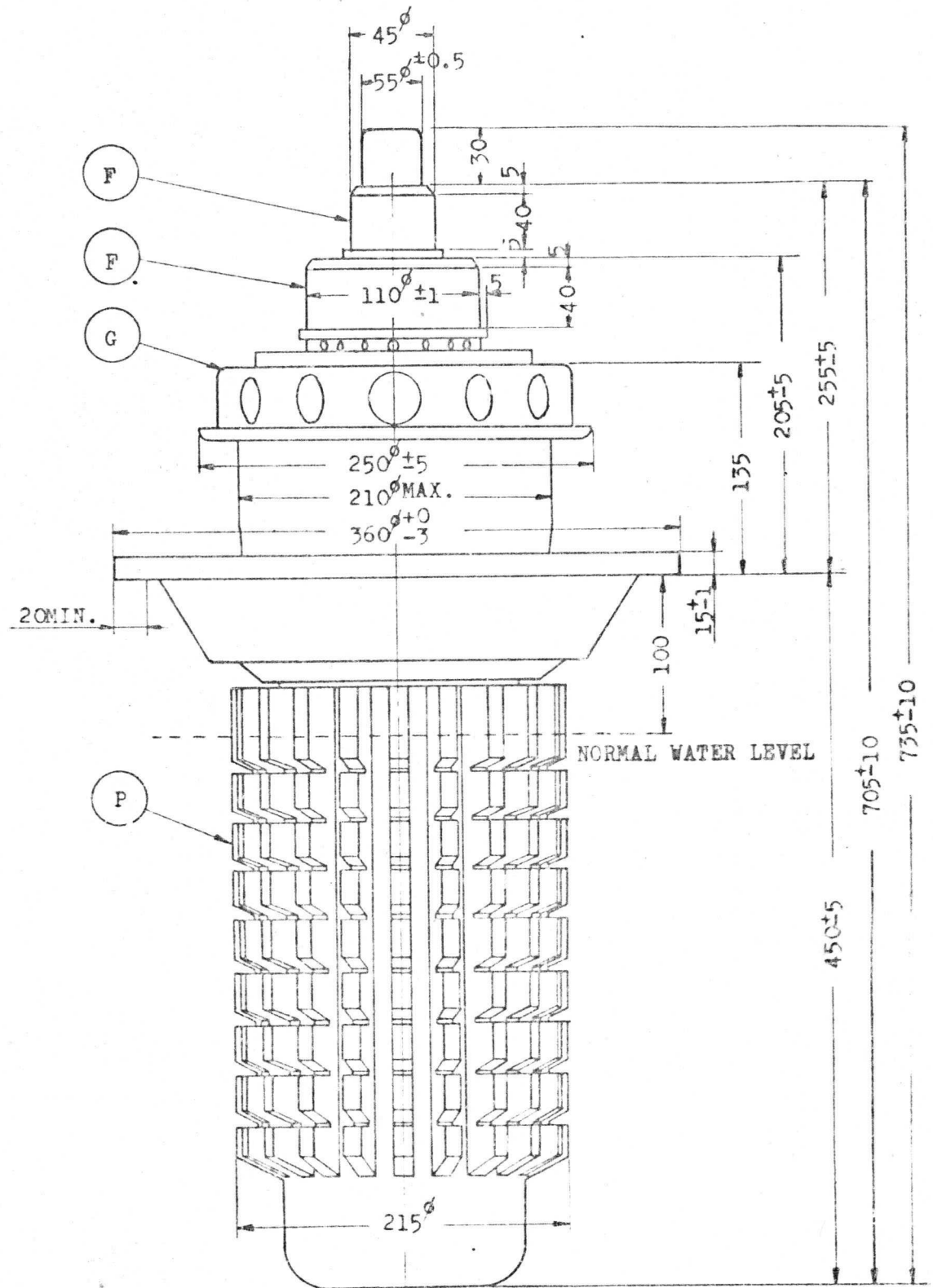

LIFTING HANDLE

(Unit in mm)

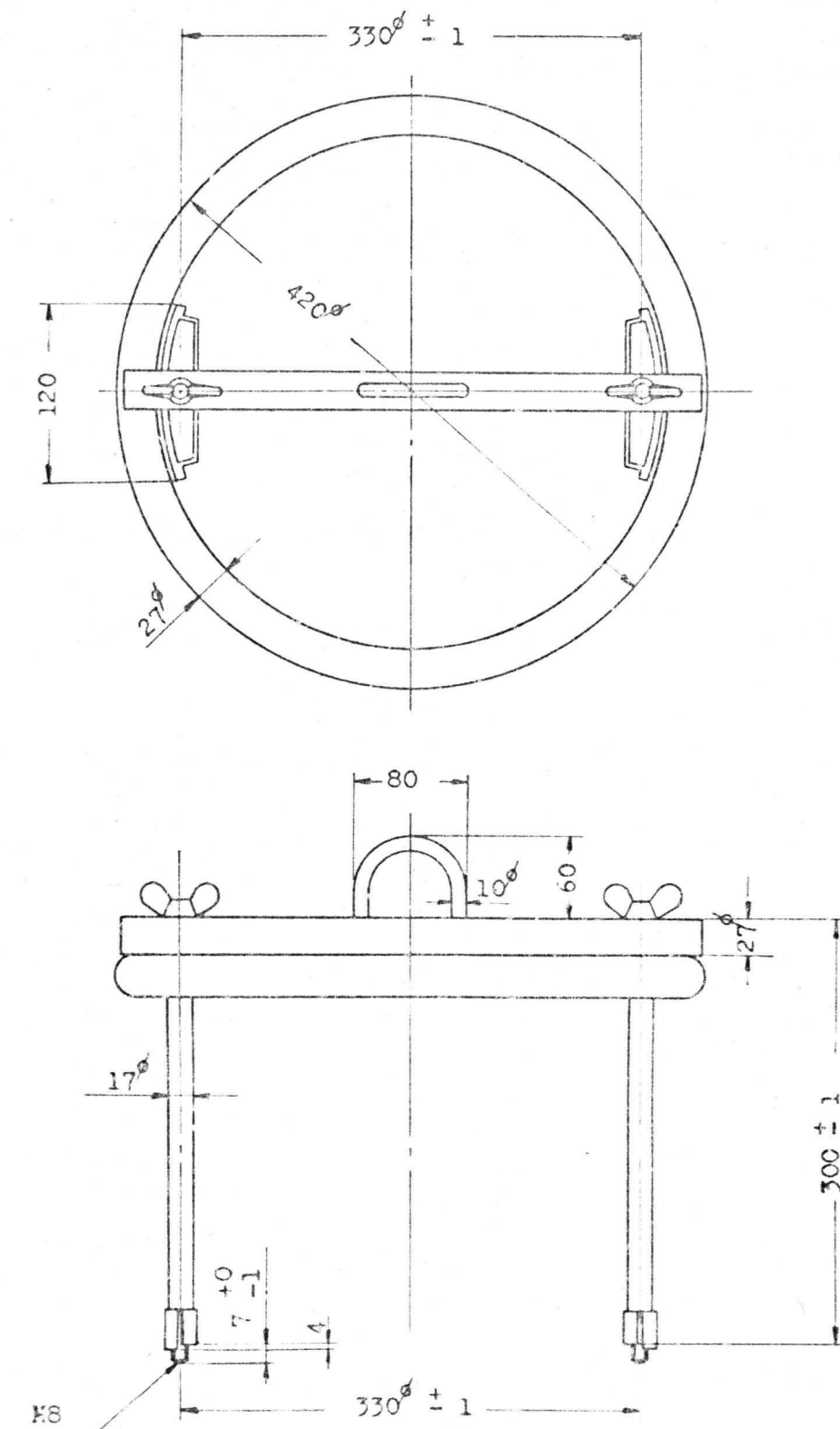



Mr. Dunham

	NEC Image Orthicon 7295A	03 4 5 8 7 1 4 2 1 5 5 0 0 2 3 3 2 1 2
--	--------------------------------	--

NEC-7295A is a 4-¹/₂-inch camera tube of the image-orthicon type intended for use in high-quality black-and-white TV cameras. The 7295A requires only a very narrow range of camera control adjustment for optimum performance and stable day-to-day operation. Because of its excellent performance capability over a wide range of different lighting conditions, the 7295A is well suited for either outdoor or studio pickup.

The 7295A features high signal-to-noise ratio, excellent resolution capability, and extremely tight limits on such important performance characteristics as sensitivity, and uniformity of sensitivity and background.

The spectral response of the 7295A approaches that of the eye. It has high blue sensitivity, high green sensitivity, and negligible infrared sensitivity.



7 2 9 5 A

D A T A

General :

Heater Voltage	6.3 ± 10%	volts
Heater Current	0.6	ampere
Direct Interelectrode Capacitance Anode to all other electrodes	12	μF
Target-to-Mesh Spacing	0.056	mm.
Spectral Response	S - 10	
Wavelength of Maximum Response	4500 ± 300	angstroms
Focusing Methode	Magnetic	
Deflection Methode	Magnetic	
Overall Length	492 ± 8	mm
Greatest Diameter of Bulb	114.3 ± 2.4	mm
Envelope Terminals	5	
End Base	Small-Shell Diheptal 14-Pin Base (JETEC Group 5 No. B14-45)	
Weight (Approx.)	1	kg
Minimum Deflecting-Coil Inside Diameter	81.9	mm
Deflecting-Coil Length	177.8	mm
Focusing-Coil Length	381	mm
Alignment Coil: position on neck	Centerline of magnetic fields should be located 235 mm from the flat area of the shoulder.	



Typical Operating Values:

Photocathode Voltage	-600	volts
Grid-No.6 Voltage (Image Focus) □		
Approx. 50% of photocathode voltage	-250 to -300	volts
Target Voltage Above Cutoff ^o	2 to 3	volts
Field Mesh Voltage##	15 to 25	volts
Grid-No.5 Voltage (Decelerator)	40	volts
Grid-No.4 Voltage (Beam Focus)	70 to 90	volts
Grid-No.3 Voltage ⊕	250 to 275	volts
Grid-No.2 & Dynode-No.1 Voltage	280	volts
Grid-No.1 Voltage for Picture Cutoff	-45 to 115	volts
Dynode-No.2 Voltage	600	volts
Dynode-No.3 Voltage	800	volts
Dynode-No.4 Voltage	1000	volts
Dynode-No.5 Voltage	1200	volts
Anode Voltage	1250	volts
Target Temperature Range	35 to 45	°C
Minimum Peak-to-Peak Blanking Voltage	5	volts
Field Strength of Focusing Coil: △		
At center of scanning section		
(Approx.)	60	gausses
In plane of photocathode (Approx.)	120	gausses
Field Strength of Alignment coil	0 to 3	gausses



Performance Data:

	Min.	Average	Max.	
Luminous Sensitivity	30	60	-	$\mu\text{A}/\text{cm}^2$
Signal-Output Current	10	-	40	μA
Ratio of Peak-to-Peak Highlight Video-signal Current to RMS Noise Current for Bandwidth of 4.5 MC	-	65.1	-	
Photocathode illumination at 2870°K Required to Reach "Knee" of Light Transfer Characteristic	-	0.4	-	lx.
Amplitude Response at 400 TV Lines per Picture Height (Percent of large-area black to large-area white)**	-	65	-	%

With respect to grid No.4

Dynode-Voltage Values are shown under Typical Operating values.

□ Adjust for optimum focus.

o The target supply voltage should be adjustable from -5 to +5 volts.

⊕ Adjust to give the most uniformly shaded picture near maximum signal.

△ Direction of current should be such that a northseeking pole is attracted to the image end of the focusing coil, with the indicator located outside of and at the image end of the focusing coil.

** Measured with amplifier having flat frequency response.

Traveling Wave Tube CW Amplifier NEC LD-550A
(Tentative Data Sheet)

The NEC LD-550A is a CW traveling-wave amplifier for operation over a frequency range of 5.8 to 8.2 kMc. For the upper half of this frequency range, this type tube has an average small signal gain of 30 db and a saturated output power of about 8 watts. For the lower half of the frequency range, the average small signal gain is 33db and the saturated output power is about 10 watts. The construction of the tube is of the conventional helical line type employing input and output waveguide couplings.

The LD-550A is available with a light-weight periodic permanent magnet focusing system, LD-550A Mount; it is convention-cooled, and operates with a collector electrode voltage that is depressed to approximately one half of the helix voltage. This latter feature produces a significant improvement in the operating efficiency.

The design, construction, and long life expectancy of the tube make it exceptionally well suited for use in point-to-point, broad-band, or multi-channel microwave relay equipments.

Features

1. PPM Focused and Field Replaceable.
2. Depressed Collector Operation For Improved Efficiency.
3. Convection Cooled.
4. Long Life.

Characteristics

Physical

Dimensions - - - - - See Outline

Weight - - - - - Tube Envelope: 0.25 Kg.
 Tube Mount: 4.6 Kg.
 Preferred Mounting Position - - Horizontal 1
 Cathode - - - - - Oxide coated, unipotential
 Connections
 RF Input & Output - - - - - WR-137 with UG-344/U flange

Electrical

Maximum Ratings 2

Accelerating Anode Voltage - - - - - 3400 V
 Accelerating Anode Current - - - - - 1.0 mA
 Helix Voltage - - - - - 3400 V
 Helix Current 3 - - - - - 1.0 mA
 Collector or Voltage, min. - - - - - 1600 V
 Collector Current - - - - - 35 mA
 Collector Dissipation - - - - - 56 W
 Focusing Electrode Voltage, max. - - - - - -20 V
 Focusing Electrode Voltage, min. - - - - - -60 V
 Ambient Temperature, max. - - - - - 55°C
 Ambient Temperature, min. - - - - - -55°C
 Collector Seal Temperature - - - - - 130°C

Operation

- Heater Voltage = 6.3 V; Heater Current at 6.3 V = 0.73A
- Frequency - - - - - 6860 ± 15 Mc
- Accelerating Anode Voltage - - - - - 2500 V
- Accelerating Anode Current - - - - - 0.01 mA
- Helix Voltage - - - - - 3100 V
- Helix Current - - - - - 0.3 mA

○ Collector Voltage - - - - -	1600 V
○ Collector Current - - - - -	35 mA
○ Focusing Electrode Voltage - - - - -	-30 V
○ RF Output (3 mW input level) - - - - -	5 W
○ RF Output Saturated - - - - -	11 W
○ Noise Figure (Small Signal) - - - - -	27 db
○ Small Signal Gain - - - - -	33 db
○ Cold and hot input match over 30 Mc/s band with matching device adjusted - - - - -	VSWR < 1.1
○ Cold output match over 30 Mc/s band with matching device adjusted - - - - -	VSWR < 1.1
○ Hot output match over 30 Mc/s band with matching device adjusted - - - - -	VSWR < 1.2
○ Gain Linearity over 30 Mc/s band - - - - -	0.2 db

Note

1. Convection cooling is sufficient when the tube is used in a horizontal position. For any other mounting position it may be necessary to direct a flow of air through the cooling fins through a convection duct or other means in order to keep the collector seal temperature at a safe operating level.
2. Ratings should not be exceeded under continuous or transient conditions. A single rating may be the limit, and simultaneous operation at another rating may not be possible.

Design values for systems should include a safety factor aimed at maintaining operation within ratings under voltage and environmental variations.
3. Helix current increases gradually with tube life. Warning of the end of tube life is given when helix current reaches 2 milliamperes.

12/28/61

Input Power vs. Output Power Characteristic

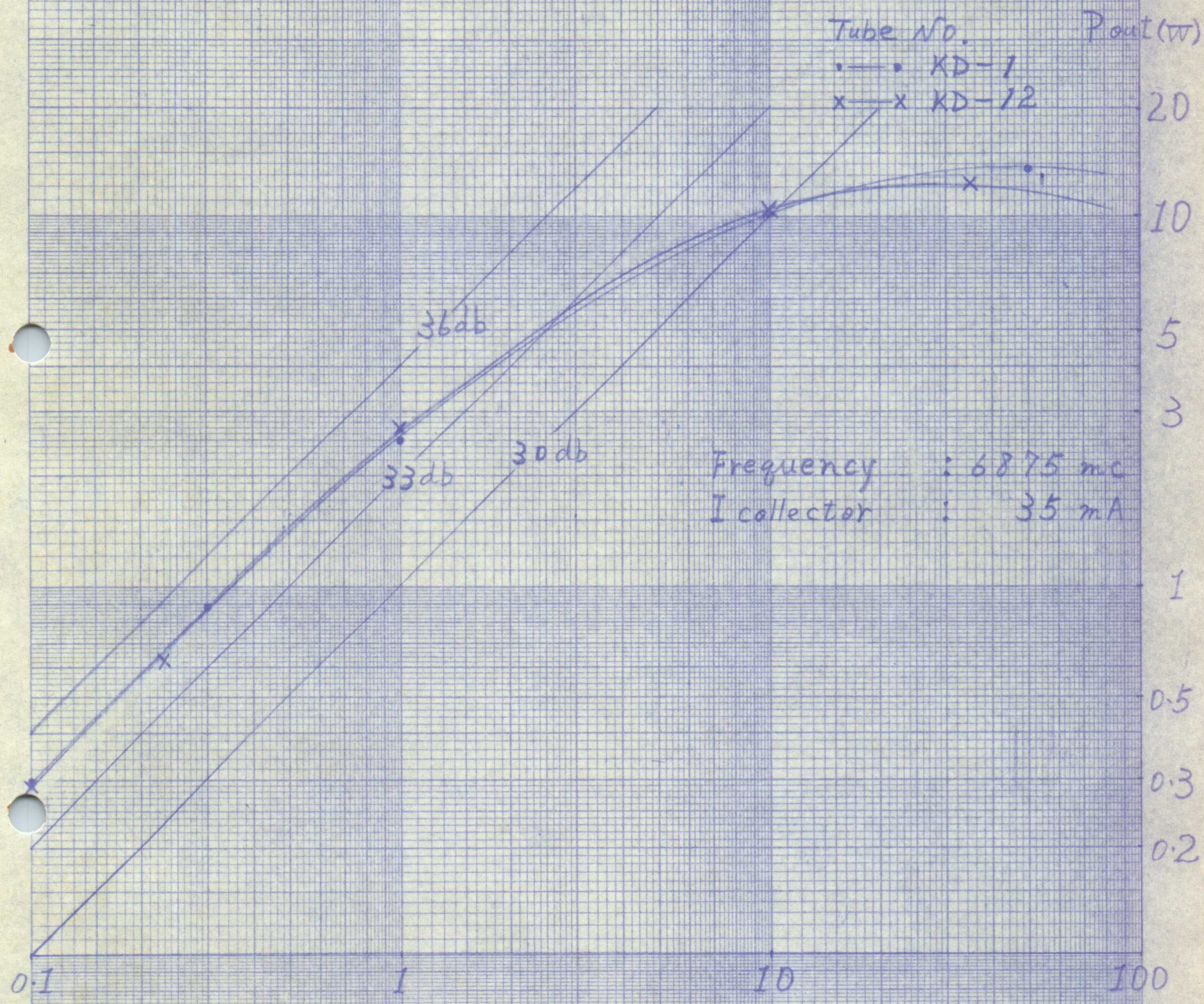

Power Input (mW)

12/28/61

Input Power vs. Output Power Characteristic.

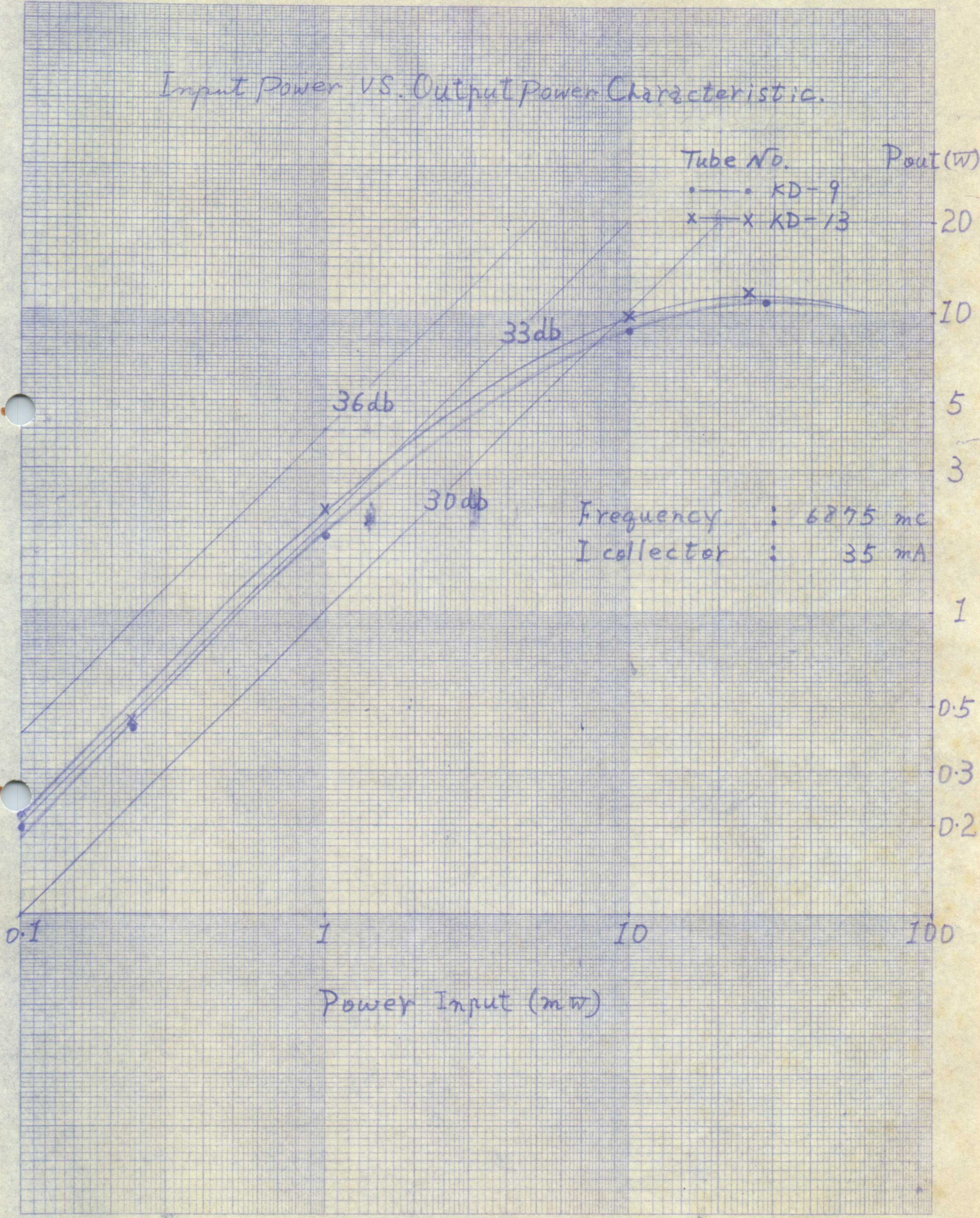

Frequency : 6875 mc
Icollector : 35 mA

Power Input (mW)

Power Output (W)

Tube No.
• KD-9
x KD-13

12/28/61

Power vs. Frequency Characteristic

Tube No. KD-1

$I_{collector} : 35 \text{ mA}$

$P_{in} : 1 \text{ mW}$

Gain (db)

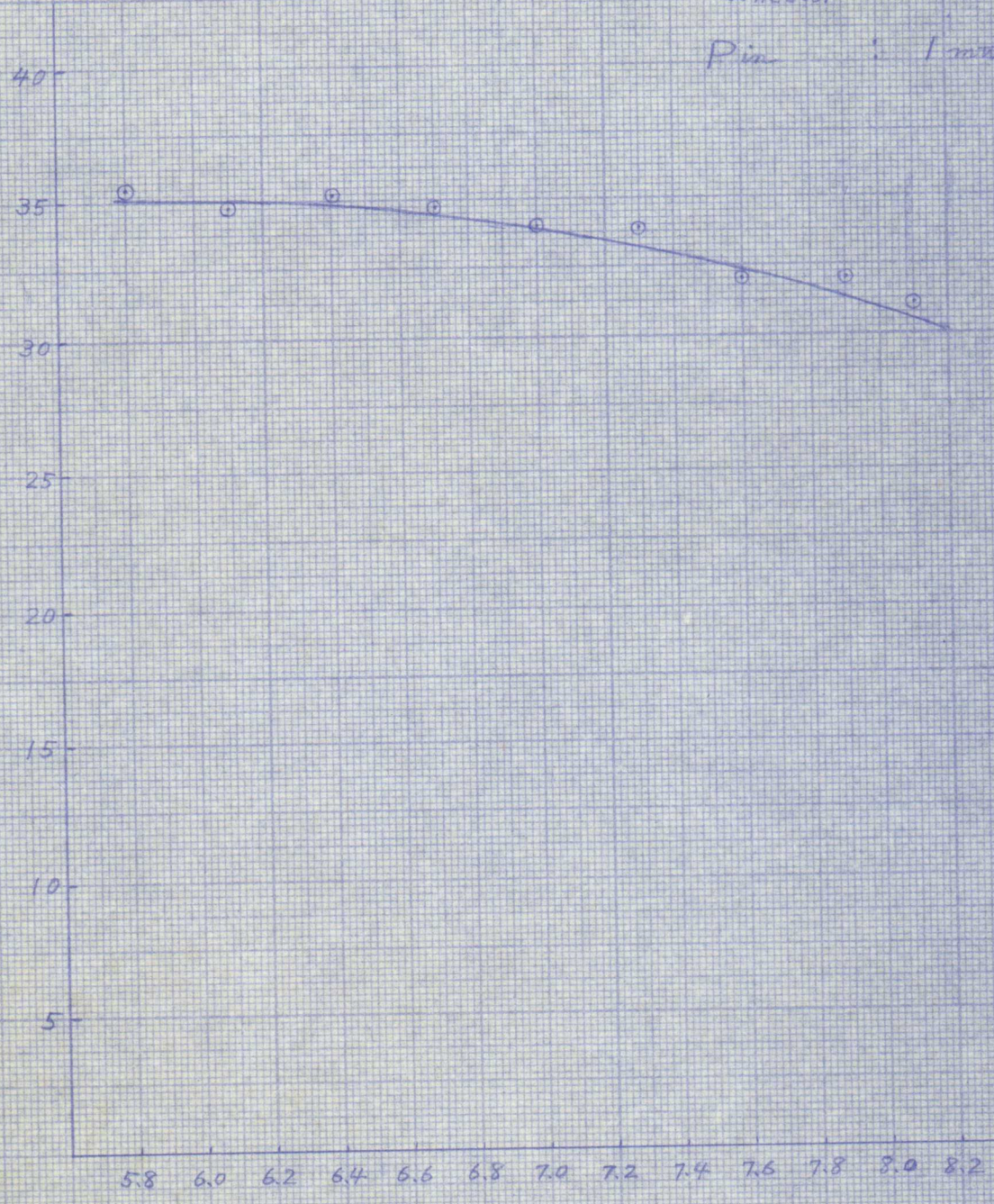

Frequency (kMc)

LD-550A AMPLIFIER

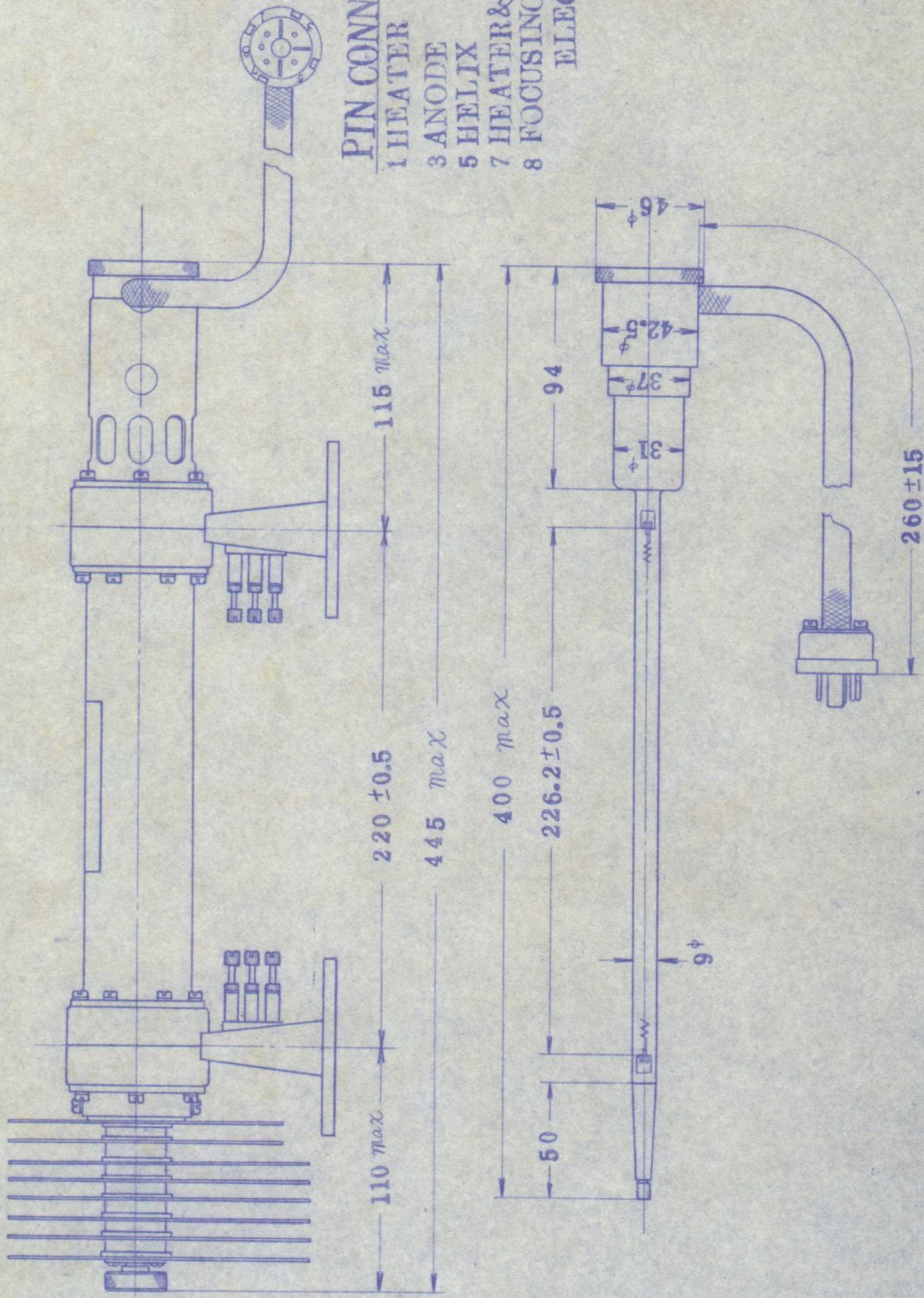

PIN CONNECTONS
 1 HEATER
 3 ANODE
 5 HELIX
 7 HEATER & CATHODE
 8 FOCUSING ELECTRODE

LD-550A TUBE ENVELOPE

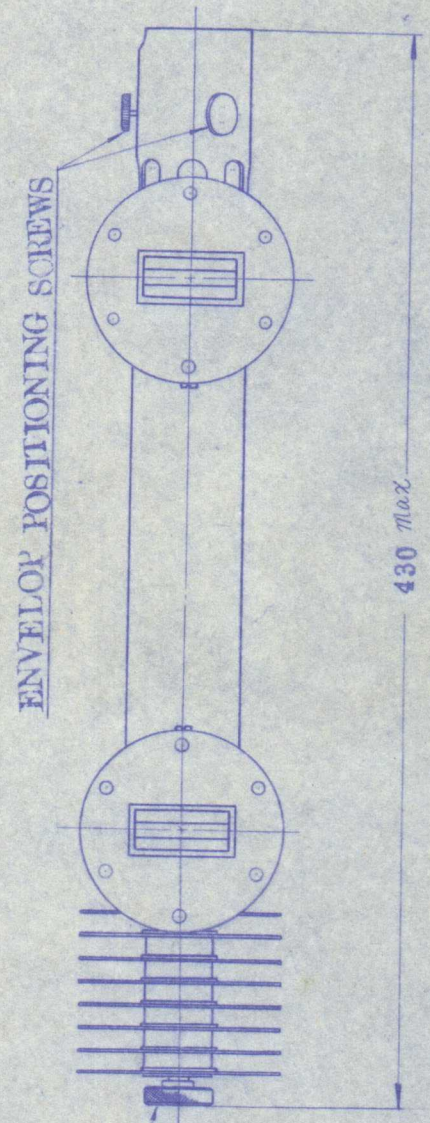
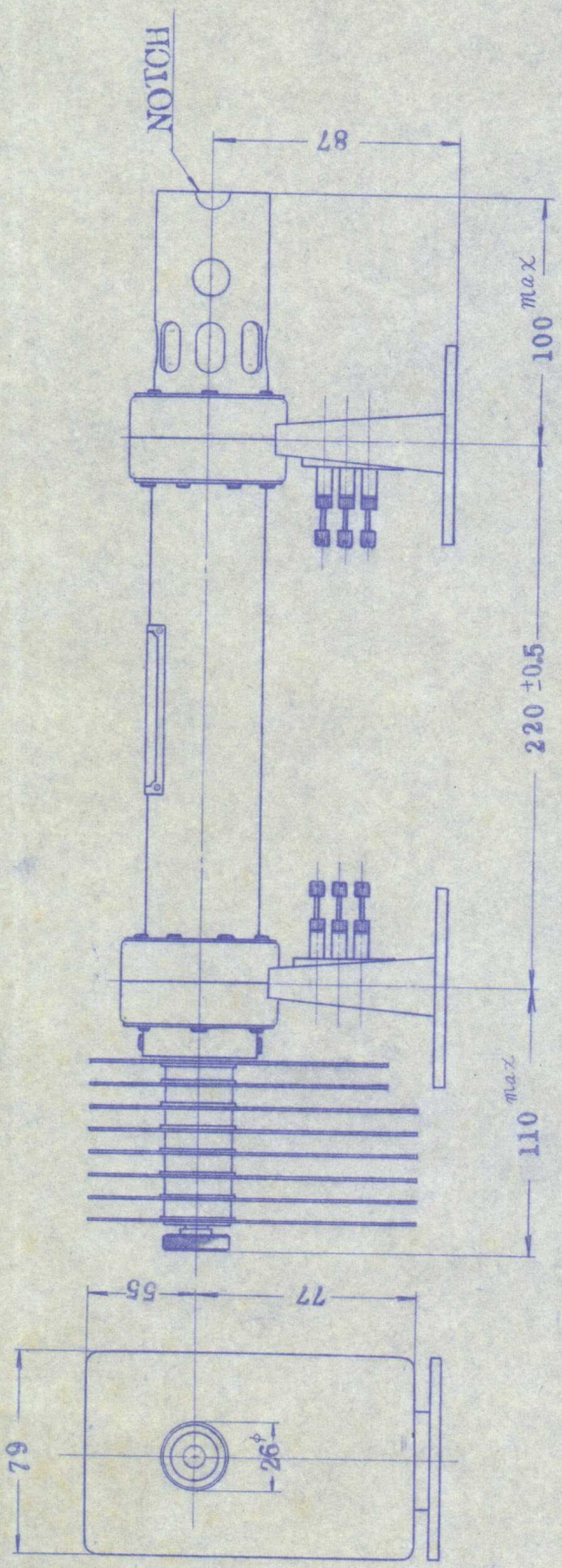

LD-550A MOUNT

Traveling Wave Tube LD-550B

Preliminary Data Sheet

The LD-550B is a CW traveling wave tube for operation over the frequency range 7.2 kMc to 8.5 kMc. The nominal gain is 40db at 1 watt output level with a typical saturation output power of 10 watts.

It is recommended that the tube be operated in the periodic permanent magnet focusing mount, type LD-550B Mount, incorporated with waveguide input and output connections fitted with matching devices. The collector electrode is depressed to approximately one half of the helix voltage and convection cooling is usually adequate when the mount is fixed with its axis horizontal and air can circulate freely past the radiator. Forced air cooling is required if the ambient temperature exceeds 55°C or the mount axis is vertical.

Tubes are fully interchangeable in the approved mount and tube replacement is a relatively simple operation.

Feature

1. PPM Focused and Field Replaceable.
2. Depressed Collector Operation for Improved Efficiency.
3. Conduction and Natural Convection Cooling.

General DataPhysical

Dimensions	See Outline
Weight	Tube Envelope : 0.23 kg (0.51 lb) LD-550B Mount : 4.3 kgs (9.5 lbs)
Preferred Mounting Position	Horizontal
Cathode	Oxide Coated, Unipotential
R.F. Connections	WR-112 with UG-51/U Flange (on LD-550B Mount)

Electrical

<u>Maximum Ratings</u> (Note 1)	Min.	Max.
Collector Voltage (Eb)	1600 Vdc	3000 Vdc
Collector Current (Ib)	—	34 mA dc
Helix Voltage (Ew)	2700 Vdc	3400 Vdc
Helix Current (Iw)	—	2.0 mA dc
Accelerating Anode Voltage (Ea)	—	3400 Vdc
Accelerating Anode Current (Ia)	—	1.0 mA dc
Focusing Electrode Voltage (Ec)	-60 Vdc	-20 Vdc
Collector Dissipation	—	56 W
Collector Seal Temperature	—	130 °C
Mount Ambient Temperature Range	-10 °C	+55 °C
Cathode Heating Time	90 sec.	—

Typical Operation

Cold input and output match over 7.2 to 7.65, 7.65 to 8.1 and 8.1 to 8.5 kMc band. VSWR < 1.4

Heater Current at 6.3 Volts 0.6 A

Frequency	7.2 kMc	7.8 kMc	8.5 kMc
Eb	1600 Vdc	1600 Vdc	1600 Vdc
Ib	33 mA dc	33 mA dc	33 mA dc
Ew	3100 Vdc	3050 Vdc	3000 Vdc
Iw	0.3 mA dc	0.3 mA dc	0.3 mA dc
Ea	2500 Vdc	2500 Vdc	2500 Vdc
Ia	0.01 mA dc	0.01 mA dc	0.01 mA dc
Ec	-35 Vdc	-35 Vdc	-35 Vdc
RF Output Power : (0.5 mW input level)	8.5 W	7.5 W	4.5 W
RF Saturated Output Power (Ew/max. Po)	14.0 W	12.0 W	10.0 W
Small Signal Gain (0.1 mW input level)	44 db	43 db	40 db
Noise Figure (Note 2) (Small signal) 28 db		

Note 1: Ratings should not be exceeded under continuous or transient conditions. A single rating may be the limitation and simultaneous operation at more than one rating may not be possible. Equipment design should allow for voltage and environmental variations so that ratings will never be exceeded.

Note 2: This noise figure is temporarily measured by signal generator method at 6320 Mc.

Operating Instructions

The following instructions provide the basic information for installing and operating the LD-550B traveling wave tube.

1. Installation of LD-550B Mount

The optimum arrangement for installation of the Mount is to provide a mounting clamp in the center of the mount between the two waveguides and then use flexible waveguides for the input and output connectors. A satisfactory alternative arrangement is to use a fixed waveguide for the output connector, supporting the mount at this point, and then use a flexible waveguide for the input connector. Rigid waveguides may also be used providing the mechanical line-up of the waveguides is adjustable to the extent that excessive pressure is not applied to the tube flanges when the flange bolts are tightened into position.

2. Stray Magnetic Field

There is a small stray magnetic field external to the tube mount. Magnetic materials should not be kept a minimum of 0.5 inch from any portion of the tube mount except the radiator and metal cap ends of tube envelope. Isolators should be located at spots suitable for avoidance of any influence on the tube current transmission. It is desirable to keep the increase of helix current due to other magnetic materials less than 0.1 mA.

3. Mounting Tube Envelope

Undo tube envelope positioning screws three on each side, and insert tube envelope into the mount so that the shielded flying leads fit into the notch provided in the mount, and set the envelope firmly in place by use of the clamping nut on the radiator. Care should be taken to avoid radial force.

4. Impedance Matching

Adjust the input and output plungers. Then adjust the impedance matching screws for a minimum cold VSWR. A cold VSWR of less than 1.1 to 1. will be attained over any 30 Mc band from 7.2 to 8.5 kMc.

5. Applications of Voltage

5.1 Apply the heater voltage and allow a minimum warm-up period of 90 seconds.

5.2 Set the focusing electrode, collector and helix voltages according to the instructions on Test Performance Sheet accompanied by each LD-550B tube envelope shipped.

It is recommended that the collector be kept at ground potential since it is connected to the tube mount internally.

5.3 Switch on all voltages. Accelerating anode voltage should be about 1500 volts.

5.4 Adjust tube position carefully to optimize current transmission by observing the helix current.

5.5 Apply the specified rf drive and adjust accelerating anode voltage until the rated collector current is reached, keeping the helix voltage at the value specified on the Test Performance Sheet.

5.6 Adjust the helix voltage for optimum operation. The helix voltage should never be made to exceed 3400 volts or fall below 2700 volts. If the helix voltage is above or below this range, the tube may be damaged by poor current transmission. The collector voltage should never be depressed below 1600 volts with respect to the cathode.

5.7 Readjust tube position and adjust the focusing electrode voltage for the best current transmission compatible with power output requirements, and then lock the tube envelope firmly to the tube mount by envelope positioning screws.

6. Dismantling Tube Envelope

After the power source is cut off, loosen all envelope positioning screws. Turn the clamping nut on the radiator in CCW several times and pull out tube envelope carefully from the mount after clamping nut has been completely disengaged.

LD-550 B

1 9.5.1963

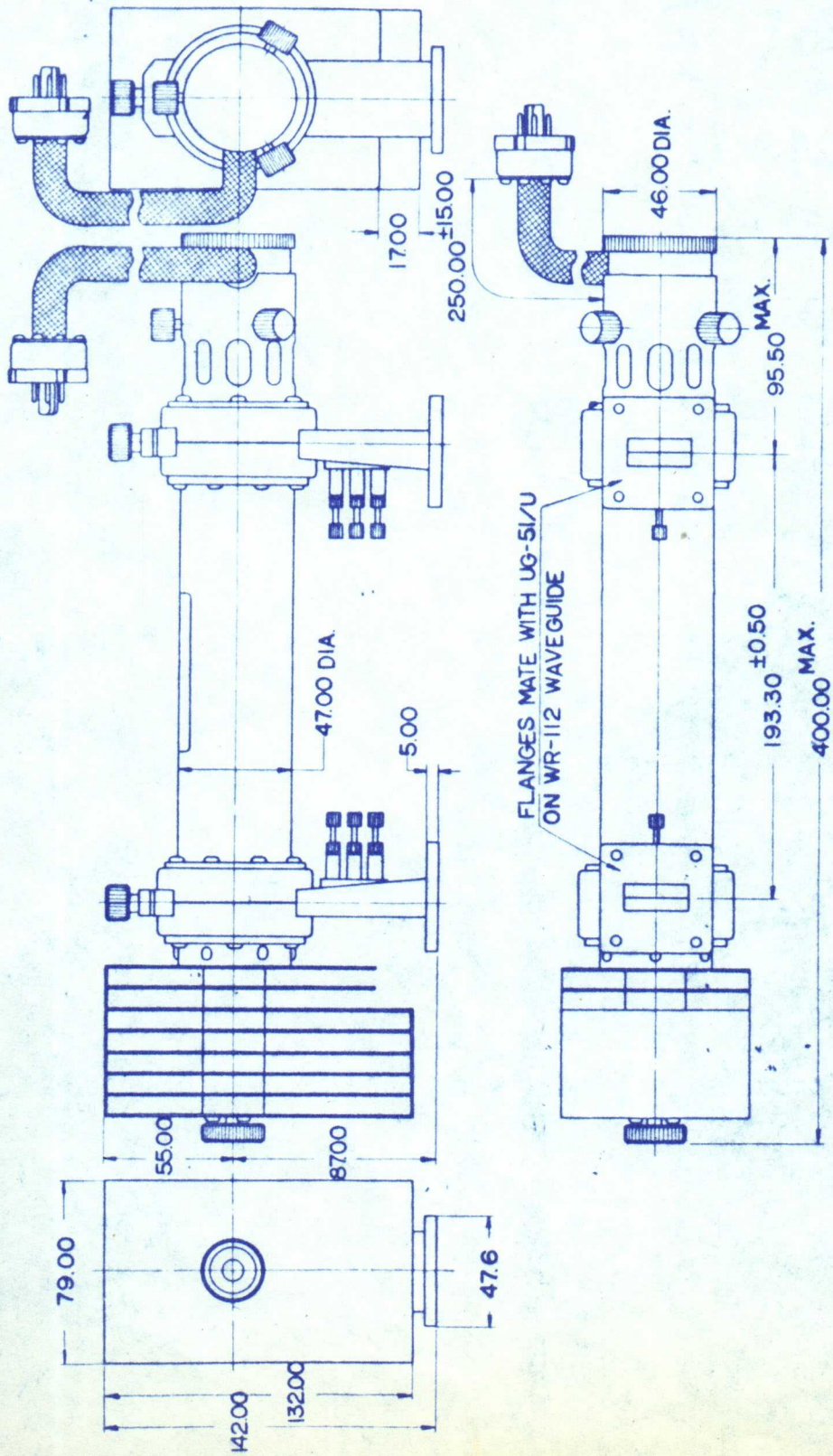

NOTES
DIMENSIONS ARE IN MILLIMETERS.

LD-550 B
OUTLINE DRAWING

製 材 名	所 要 寸 度	仕 上 お よ び 処 理
特 許 登 記 商 標 有 限 公 司	電 子 技 術 研 究 所	

特 許 登 記 商 標 有 限 公 司	尺 度	カ 三 角 法
製 品 名		
仕 様 番 号		
組 立 図 番		

SB-67277

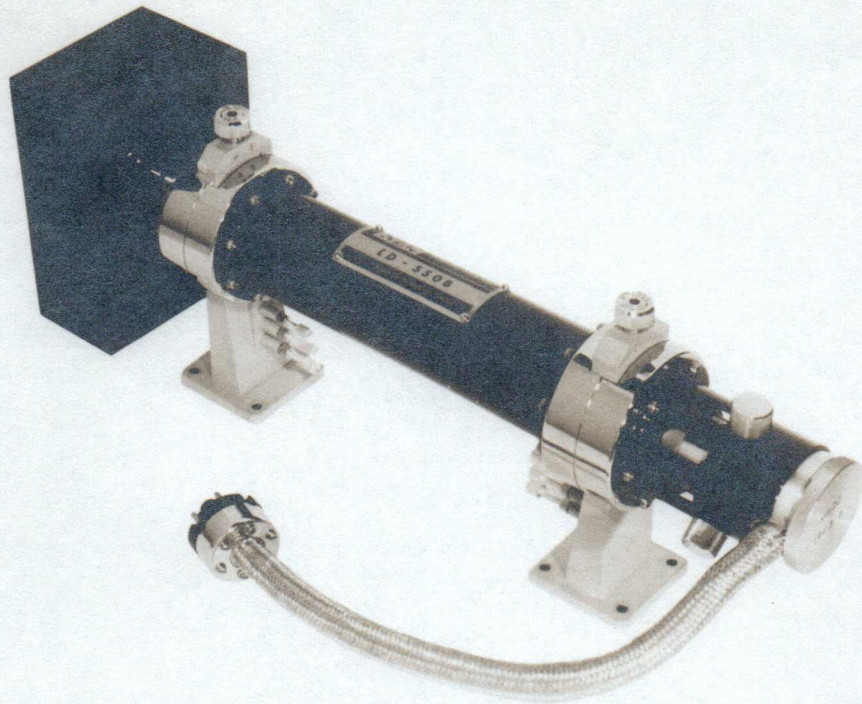

TP-40566

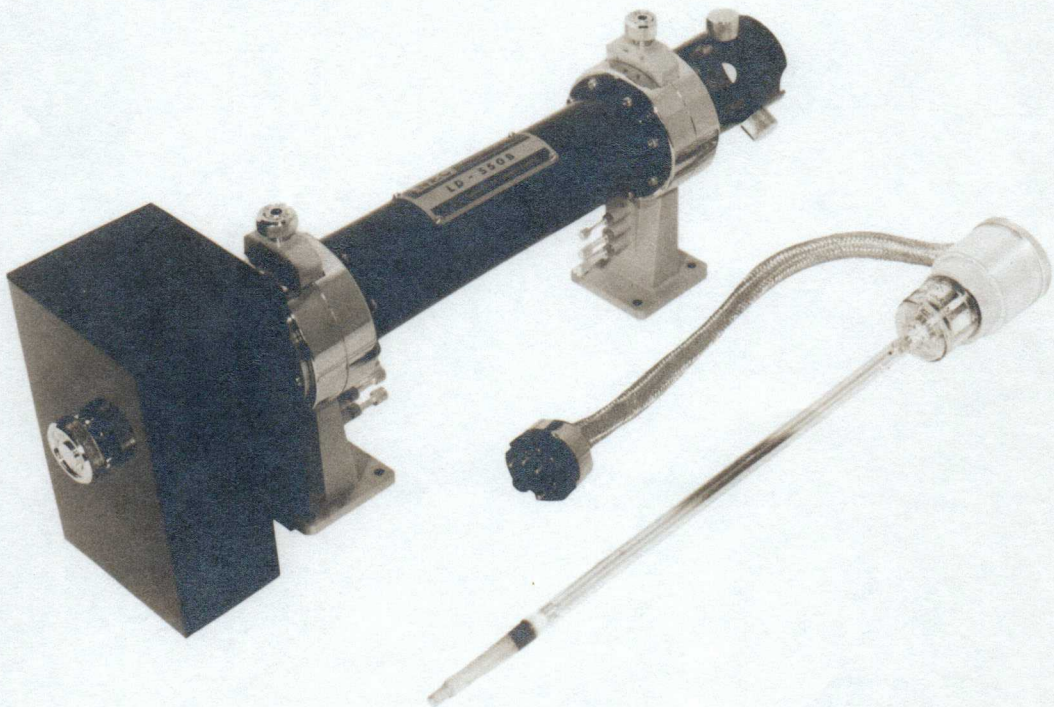

TP-40567

S-Band Low Noise Traveling Wave Tube

LD-570

Tentative Data Sheet

The LD-570 is suitable for a microwave preamplifier stage where low noise figure is required. The LD-570 has a maximum noise figure of 6.5 db and a minimum small signal gain of 20 db, and is used over the frequency band of 2,700 to 2,900 Mc/s without readjustment of tuning devices. Application of this tube include radar receivers, electronic counter-measure equipment, microwave relay systems and so on.

General Characteristics:

Electrical

Heater Voltage	4 to 7 V
Heater Current	0.7 A Max.
Frequency Range	2,700 to 2,900 Mc/s
Noise Figure	6.5 db Max.
Small Signal Gain	20 db Min.
Input and Output VSWR	2.0 Max.

Mechanical

Mounting Position	Any
RF Connection	Coaxial Connector, Type N Plugs (UG-21D/U)
Socket	Octal base
Collector Connector	Special size
Dimension	See Outline Drawing
Weight	1K grs.
Cooling	Natural

Typical Operation

Frequency	2,800 Mc/s
Heater Voltage	5.7 V
Heater Current	0.43 A
Grid Voltage	0 V
Anode 1 Voltage	19.7 V
Anode 2 Voltage	41 V
Anode 3 Voltage	330 V
Anode 1, 2 & 3 Current	0 μ A
Helix Voltage	437 V
Helix Current	0.1 μ A
Collector Voltage	700 V
Collector Current	200 μ A
Magnetic Field Strength	650 gauss
Noise Figure	5.5 db
Small Signal Gain	28 db
Saturated Power Output	3 mW

TYPICAL OPERATION OF LD-570

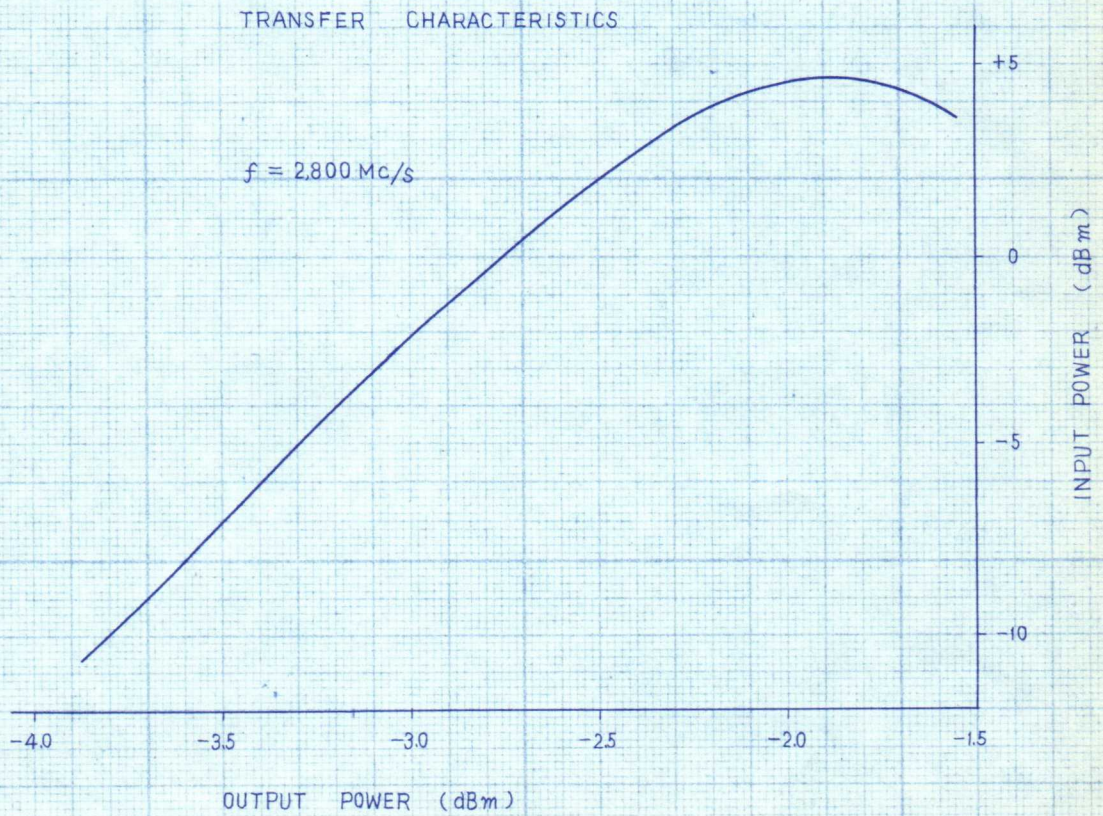
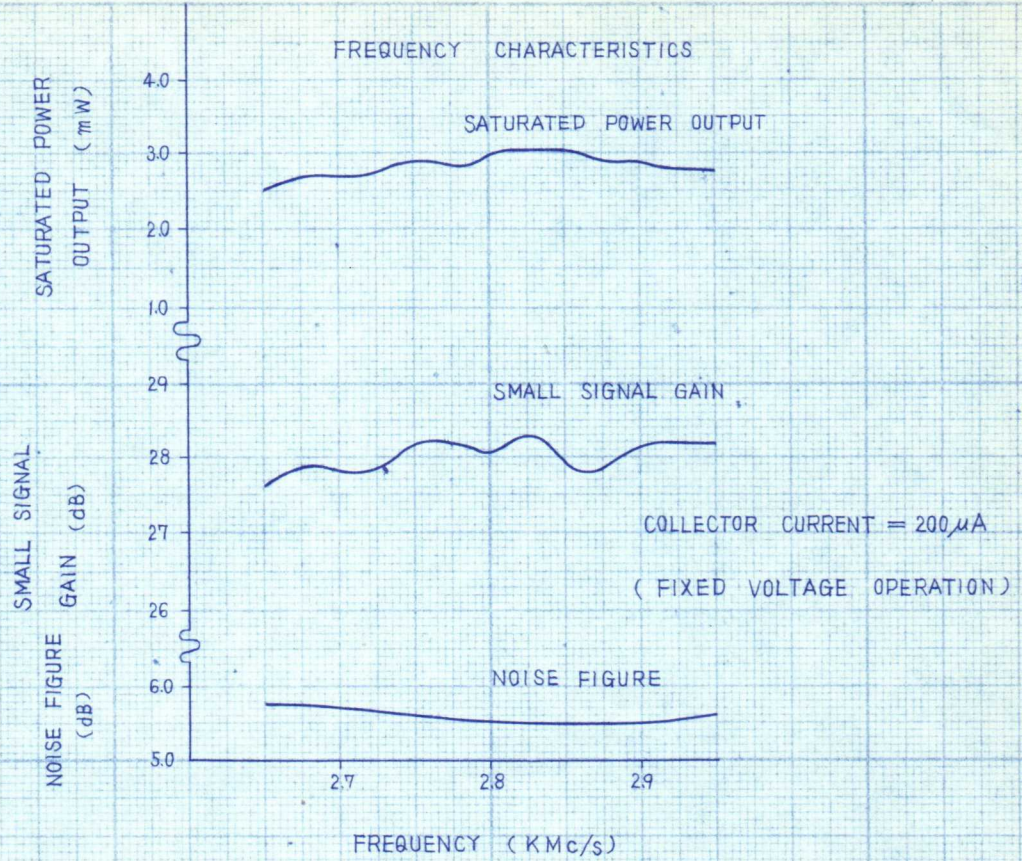

OUTLINE OF LD-570

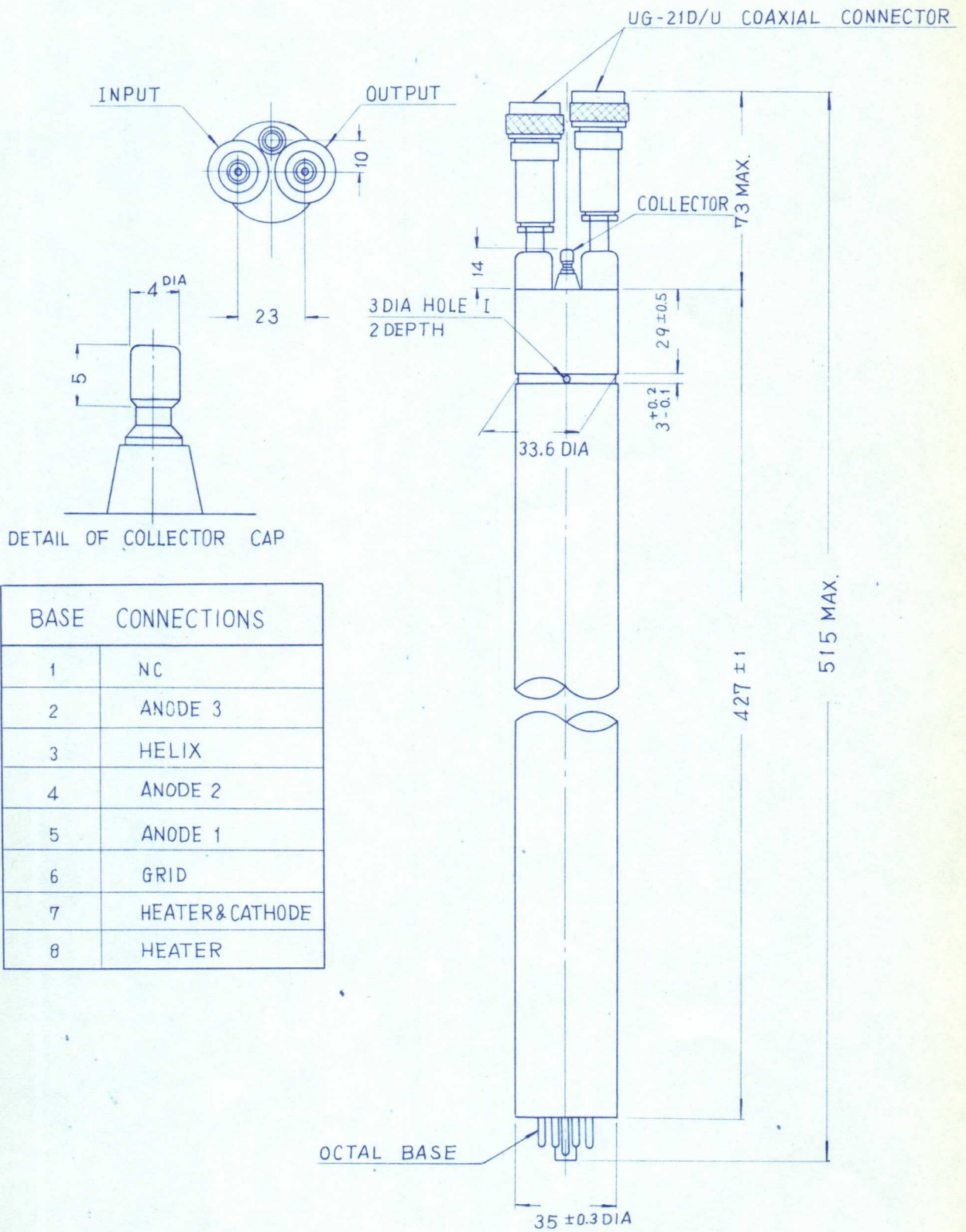

BASE CONNECTIONS	
1	NC
2	ANODE 3
3	HELIX
4	ANODE 2
5	ANODE 1
6	GRID
7	HEATER & CATHODE
8	HEATER

NOTE : DIMENSIONS ARE IN MILLIMETERS.



TP-42785

X-Band Low Noise Traveling Wave Tube

LD-571/(9W90)

(Tentative Data Sheet)

NEC

The LD-571 is suitable for a microwave preamplifier stage where low noise figure is required. The LD-571 has a maximum noise figure of 8.5 db and a minimum small signal gain of 20 db, and is used over the frequency band of 8,950 to 9,200 Mc/s without readjustment of tuning devices. Application of this tube include radar receivers, electrical counter-measure equipments, microwave relay systems and so on.

The special tube which operates over the expanded frequency band of 8,500 to 9,500 Mc/s is also available on request.

General CharacteristicsElectrical

Heater Voltage	4 to 7 V
Heater Current	0.7 A
Frequency range	8,950 to 9,200 Mc/s
Noise Figure	8.5 db Max.
Small Signal Gain	20 db Min.
Input and Output VSWR	2.0 Max.

Mechanical

Mounting Position	Any
RF Connection	Reduced Height of RG-52/U Special flange
Socket	Octal base
Collector Connector	Special size
Dimension	See Outline Drawing
Weight	800 grs.
Cooling	Natural

Typical Operation

Frequency	9,080 Mc/s
Heater Voltage	6.0 V
Heater Current	0.50 A
Grid Voltage	-5.0 V
Anode 1 Voltage	22.2 V
Anode 2 Voltage	115 V
Anode 3 Voltage	550 V
Helix Voltage	880 V
Helix Current	0.3 μ A
Collector Voltage	1200 V
Collector Current	200 μ A
Magnetic Field Strength	800 Gauss
Noise Figure	6.5 db
Small Signal Gain	25 db
Saturated Power Output	3.8 mW

TYPICAL OPERATION OF LD-571

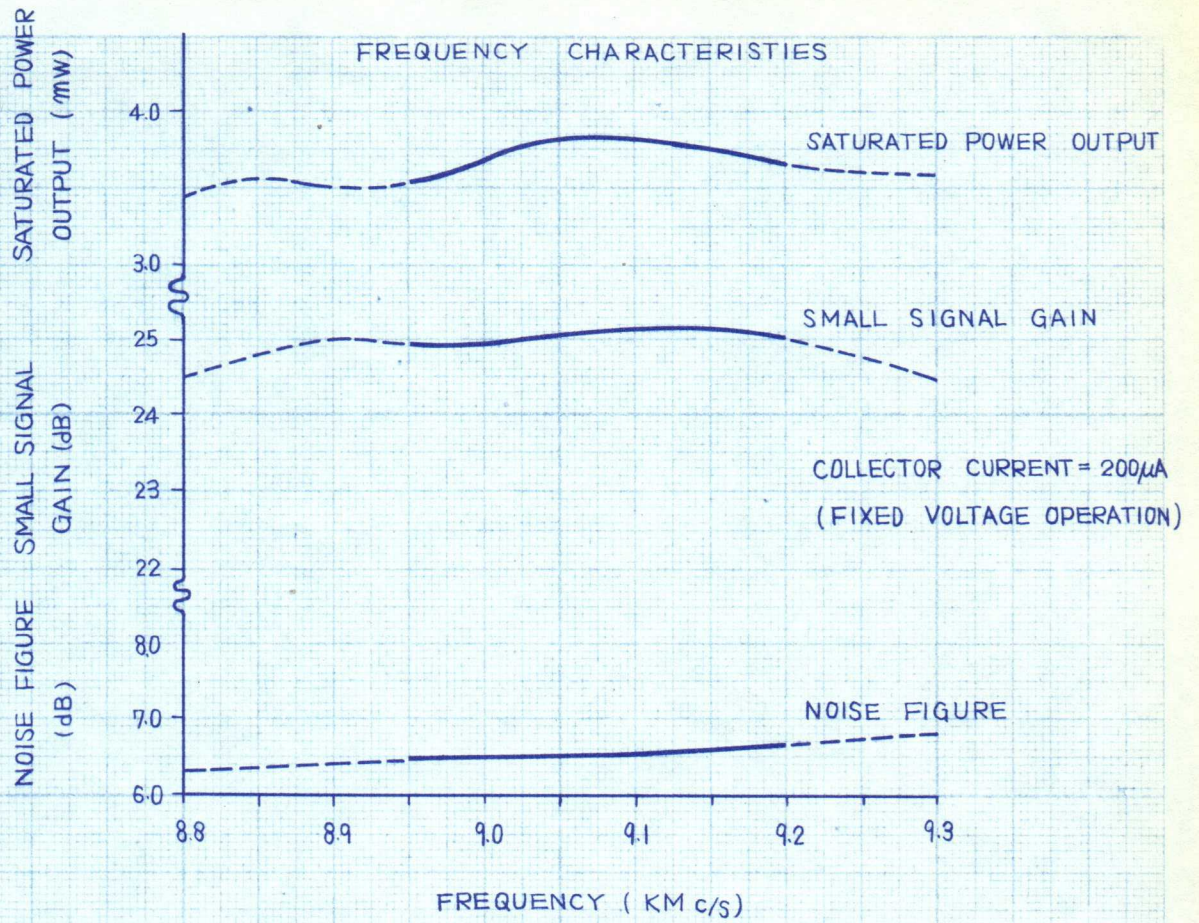

TRANSFER CHARACTERISTICS

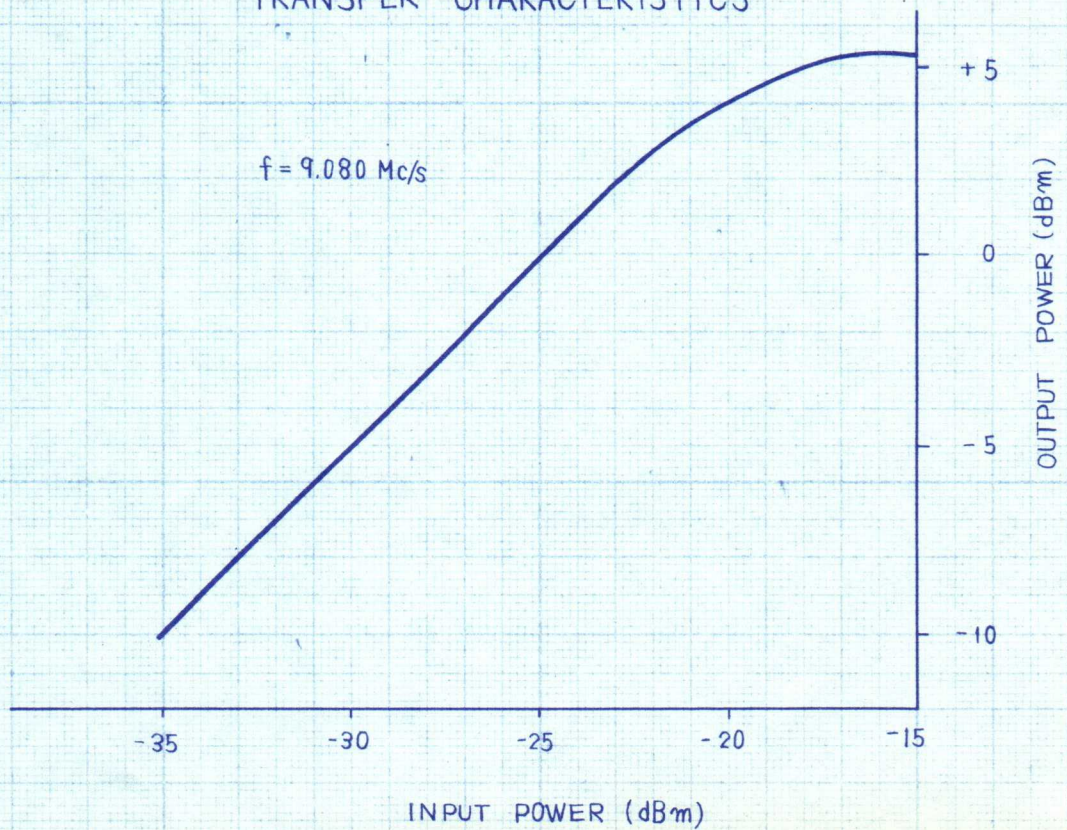

OUTLINE OF LD-571

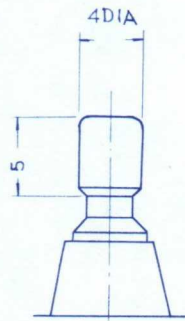
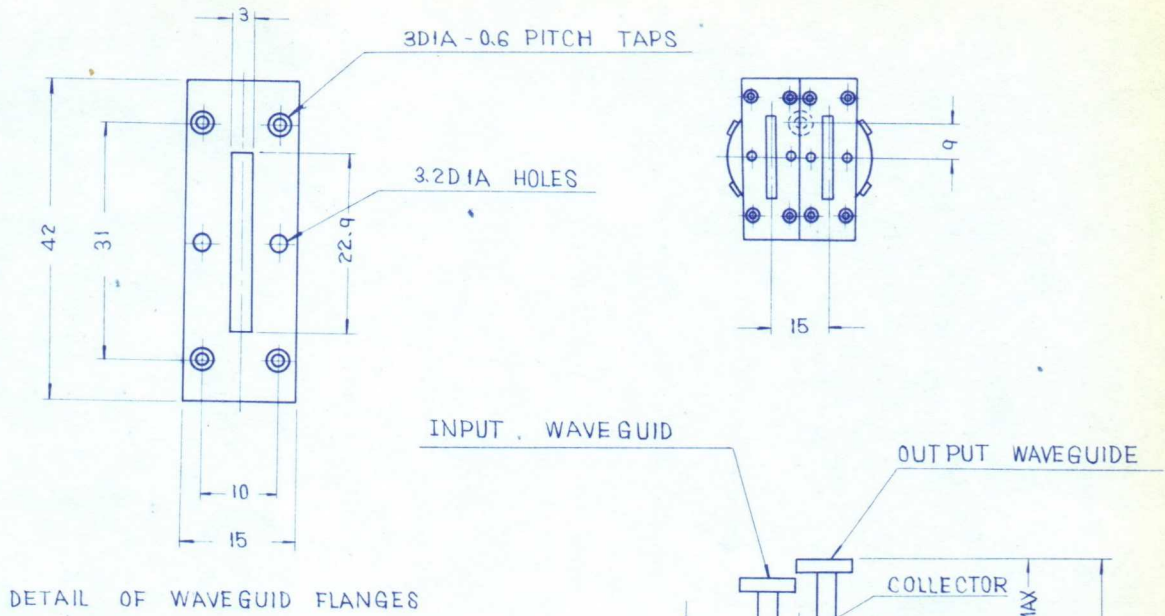

DETAIL OF COLLECTOR CAP

BASE	CONNECTION
1	NC
2	ANODE 3
3	HELIX
4	ANODE 2
5	ANODE 1
6	GRID
7	HEATER & CATHODE
8	HEATER

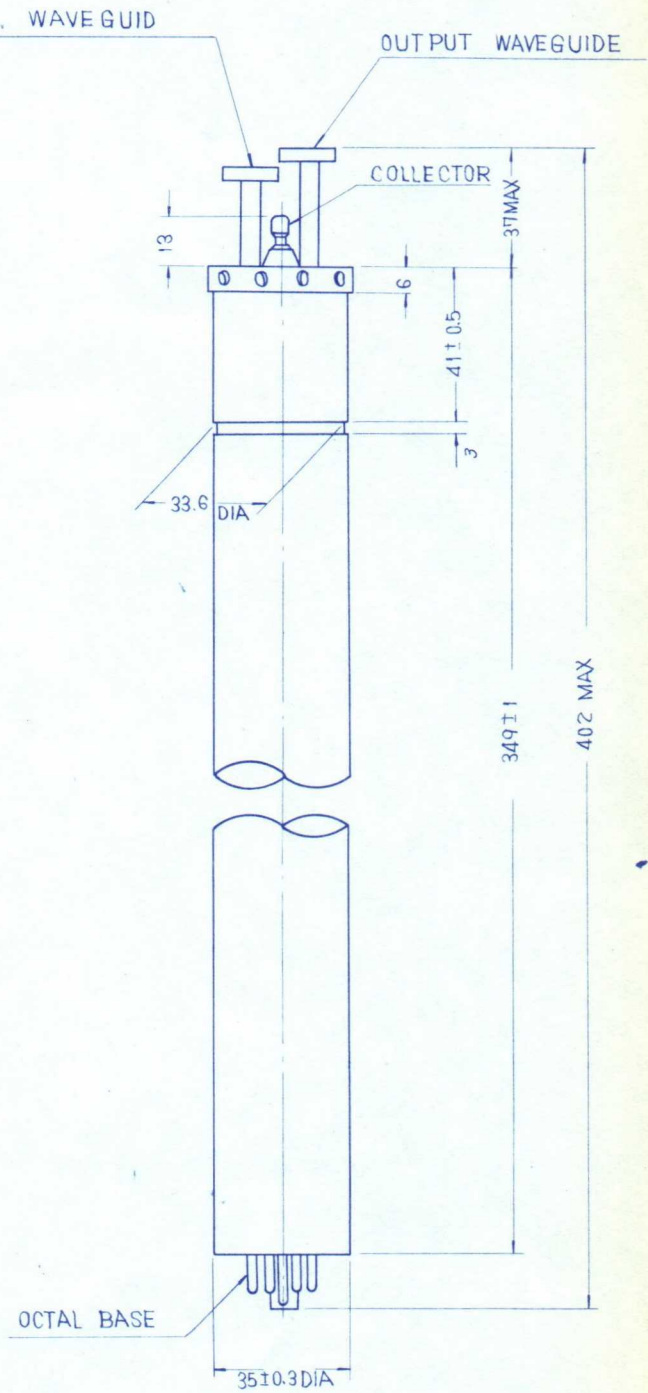

NOTE : DIMENSIONS ARE IN MILLIMETERS



TP-42786

Low Noise Traveling Wave Tube

LD - 590

Tentative Data Sheet

NEC

The LD-590 is a low noise traveling wave tube for operation over the frequency range 3,600 to 4,200 Mc/s. The nominal noise figure is 6.5db and the nominal gain at small signal level is 28db with a typical saturated power output of 3mW.

The tube operates in a solenoid type focusing mount with input and output waveguides.

General Characteristics:Electrical

Heater Voltage	4 to 7 V
Heater Current	0.6A Max.
Frequency Range	3,600 to 4,200 Mc/s
Noise Figure	7.5db Max.
Small Signal Gain	25db Min.

Mechanical

Mounting Position	Any
RF Connection	Waveguides
Socket	Octal Base
Collector Connector	Special Size
Dimensions	See Outline Drawing
Weight	250 grs.
Cooling	Natural

Nippon Electric Company Limited.

P.O. Box 1, Takanawa, Tokyo, Japan

PRINTED IN JAPAN

VES-3523

3.15.1965

Typical Operation

Frequency	4.170 Mc/s
Heater Voltage	6.0 V
Heater Current	0.45A
Grid Voltage	0 V
Anode 1 Voltage	20 V
Anode 2 Voltage	45 V
Anode 3 Voltage	380 V
Anode 1, 2 & 3 Currents	0 μ A
Helix Voltage	540 V
Helix Current	0.2 μ A
Collector Voltage	800 V
Collector Current	200 μ A
Magnetic Flux Density	700 gauss over the electron gun region and 580 gauss over the helix region
Noise Figure	6.5 db
Small Signal Gain	28 db
Saturated Power Output	3 mW

OUTLINE OF LD-590

BASE CONNECTION	
1	NC
2	ANODE 3
3	HELIX
4	ANODE 2
5	ANODE 1
6	GRID
7	HEATER & CATHODE
8	HEATER

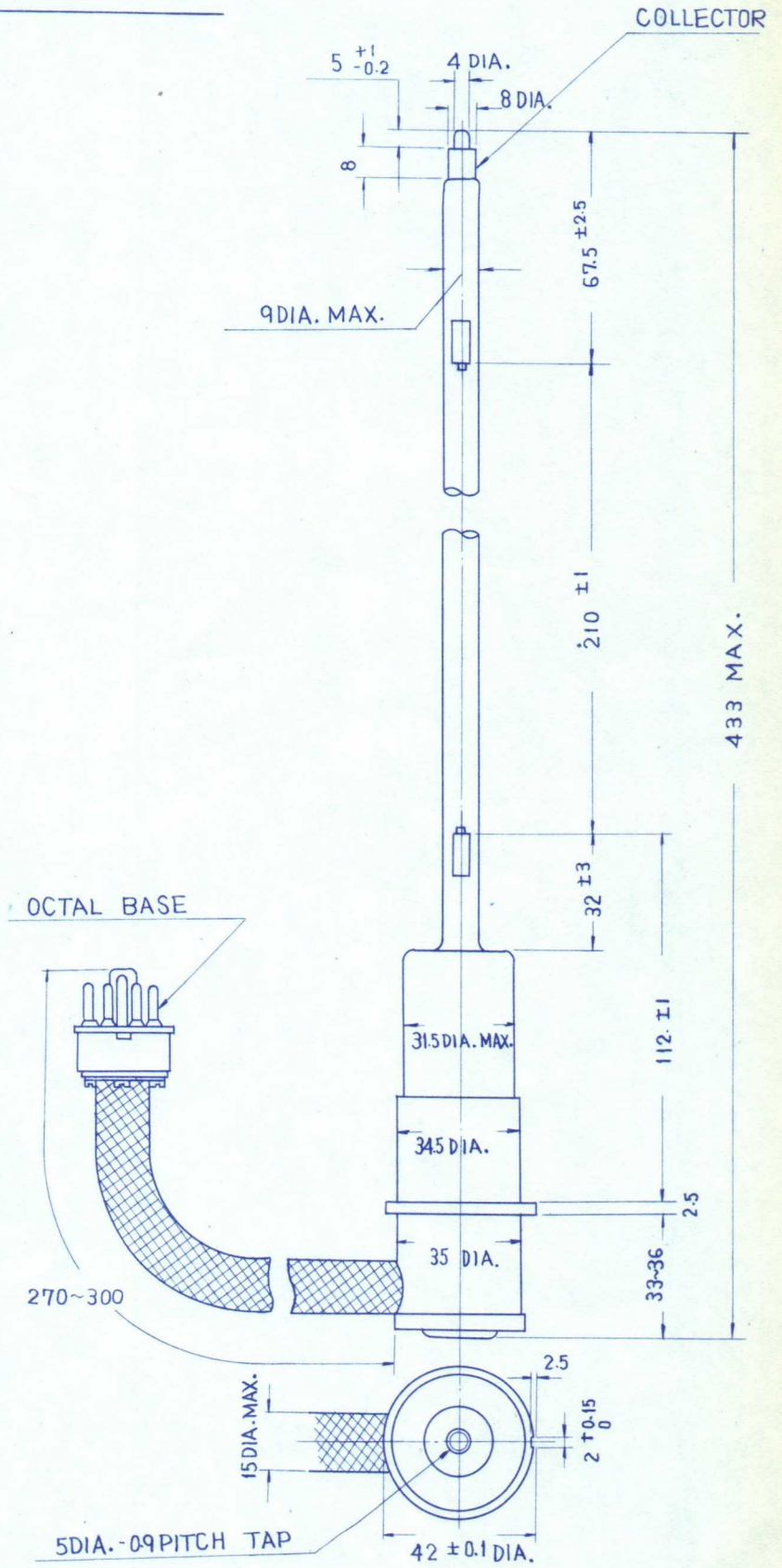

NOTE : DIMENSIONS ARE
IN MILLIMETERS.

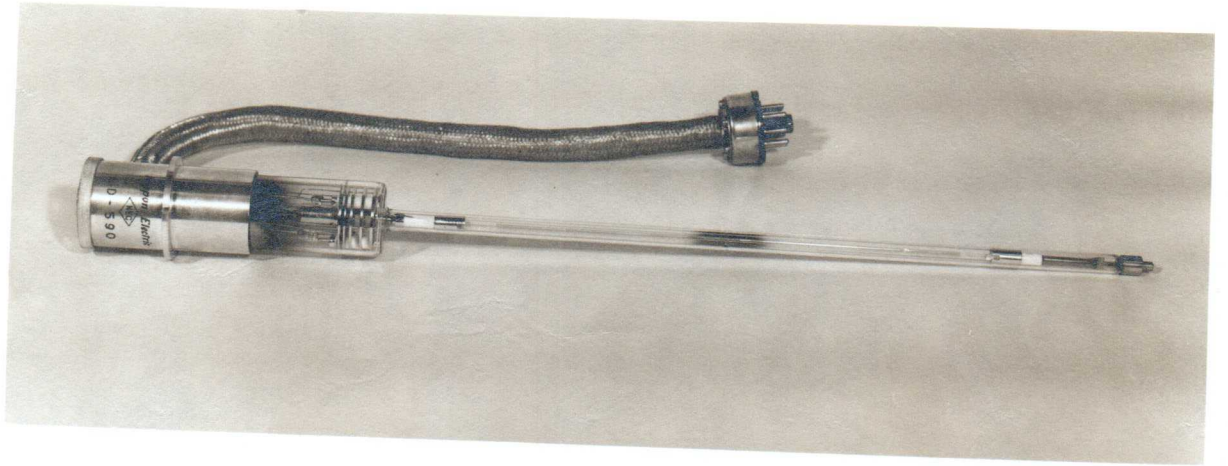

Traveling Wave Tube LD-597A

Preliminary Data Sheet

The LD-597A is a CW traveling wave tube for operation over the frequency range 3.6 kMc to 4.2 kMc. The minimum gain is 33db at 6 watt output level with a typical saturation output of 14 watts.

It is recommended that the tube be operated in the periodic permanent magnet focusing mount, type LD-597A Mount, incorporated with waveguide input and output connectors fitted with matching devices. The collector electrode is depressed to approximately two thirds of the helix voltage and convection cooling is usually adequate when the mount is fixed with its axis vertical and air can circulate freely past the radiator. Forced air cooling is required if the ambient temperature exceed 55°C or the mount axis is horizontal.

Tubes are fully interchangeable in the approved mount and tube replacement is a relatively simple operation.

Feature

1. PPM Focused and Field Replaceable.
2. Depressed Collector Operation for Improved Efficiency.
3. Conduction and Natural Convection Cooling.

General DataPhysical

Dimensions	See Outline
Weight	Tube Envelope: 0.27 kg. (0.6 lb) LD-597A Mount: 4.4 kgs. (9.7 lbs)
Preforred Mounting Position ..	Vertical
Cathode	Oxide Coated, Unipotential
R.F. Connections	Reduced Height WR 229 (on LD-597A Mount)

Electrical

<u>Maximum Ratings</u>	Min.	Max.
Collector Voltage (Eb)	1700 Vdc	2000 Vdc
Collector Current (Ib)	-	35 mAdc
Helix Voltage (Ew)	2600 Vdc	3000 Vdc
Helix Current (Iw)	-	1.5 mAdc
Accelerating Anode Voltage (Ea)	-	3500 Vdc
Accelerating Anode Current (Ia)	-	0.5 mAdc
Focusing Electrode Voltage (Ec)	-55 Vdc	-45 Vdc
Collector Dissipation	-	63 W
Collector Seal Temperature	-	180 °C
Mount Ambient Temperature Range	-10 °C	+55 °C
Cathode Heating Time	90 sec.	-

Typical Operation

Cold input and output match over 600 Mc band

(adjusted for each tube envelope) VSWR: 1.25

Heater Current at 6.3 Volts 0.7 A

Frequency	3.7 kMc	4.0 kMc	4.2 kMc
Eb	1700 Vdc	1700 Vdc	1700 Vdc
Ib	35 mAdc	35 mAdc	35 mAdc
Ew	2800 Vdc	2750 Vdc	2730 Vdc
Iw	0.14 mAdc	0.15 mAdc	0.15 mAdc
Ea	3110 Vdc	3110 Vdc	3110 Vdc
Ia	0.01 mAdc	0.01 mAdc	0.01 mAdc
Ec	-50 Vdc	-50 Vdc	-50 Vdc
RF Output power (3mW input level)	9.1 W	8 W	7.4 W
RF Saturated Output	15.6 W	14.6 W	14.2 W
Noise Figure (Small Signal, f = 4.17 kMc)	25 db		

Operating Instructions

The following instructions provide the basic information for installing and operating the LD-597A traveling wave tube.

1. Mounting Tube Envelope

Undo tube envelope positioning screws three on each side, and insert tube envelope into the mount so that the shielded flying leads fit into the notch provided in the mount, and set the envelope firmly in place by use of the clamping nut on the radiator. Care should be taken to avoid radial force.

2. Impedance Matching

Adjust the input and output plungers by plunger adjusting tool accompanied by each LD-597A Mount.

Then adjust the impedance matching screws for a minimum cold VSWR. A cold VSWR of less than 1.4 to 1 will be attained over the frequency range 3.6 to 4.2 kMc.

3. Application of Voltage

- 3.1 Apply the heater voltage and allow a minimum warm-up period of 90 seconds.
- 3.2 Set the focusing electrode, collector and helix voltages according to the instructions on Test Performance Sheet accompanied by each LD-597A tube envelope shipped. It is recommended that the collector be kept at ground potential since it is connected to the tube mount internally.
- 3.3 Switch on all voltages. Accelerating anode voltage should be about 1750 volts.
- 3.4 Adjust tube position carefully to optimize current transmission by observing the helix current.
- 3.5 Apply the specified rf drive and adjust accelerating anode voltage until the rated collector current is reached, keeping the helix voltage at the value specified.
- 3.6 Adjust the helix voltage for maximum power output. The helix voltage should never be made to exceed 3000 volts or fall below 2600 volts. If the helix voltage is above or below this range, the tube may be damaged by poor current transmission. The collector voltage should never be depressed below 1700 volts with respect to the cathode.
- 3.7 Readjust tube position for the best current transmission, and then lock the tube envelope firmly to the tube mount by envelope positioning screws.
- 3.8 From the economical point of view, it is recommended that the collector current be kept as small as possible compatible with the satisfactory operating performance of LD-597A.

4. Dismantling Tube Envelope

After the power source is cut off, loosen all envelope positioning screws. Turn the clamping nut on the radiator in CCW several times and pull out tube envelope carefully from the mount after clamping nut has been completely disengaged.

数量 1
 年月日 38-9-7
 承認

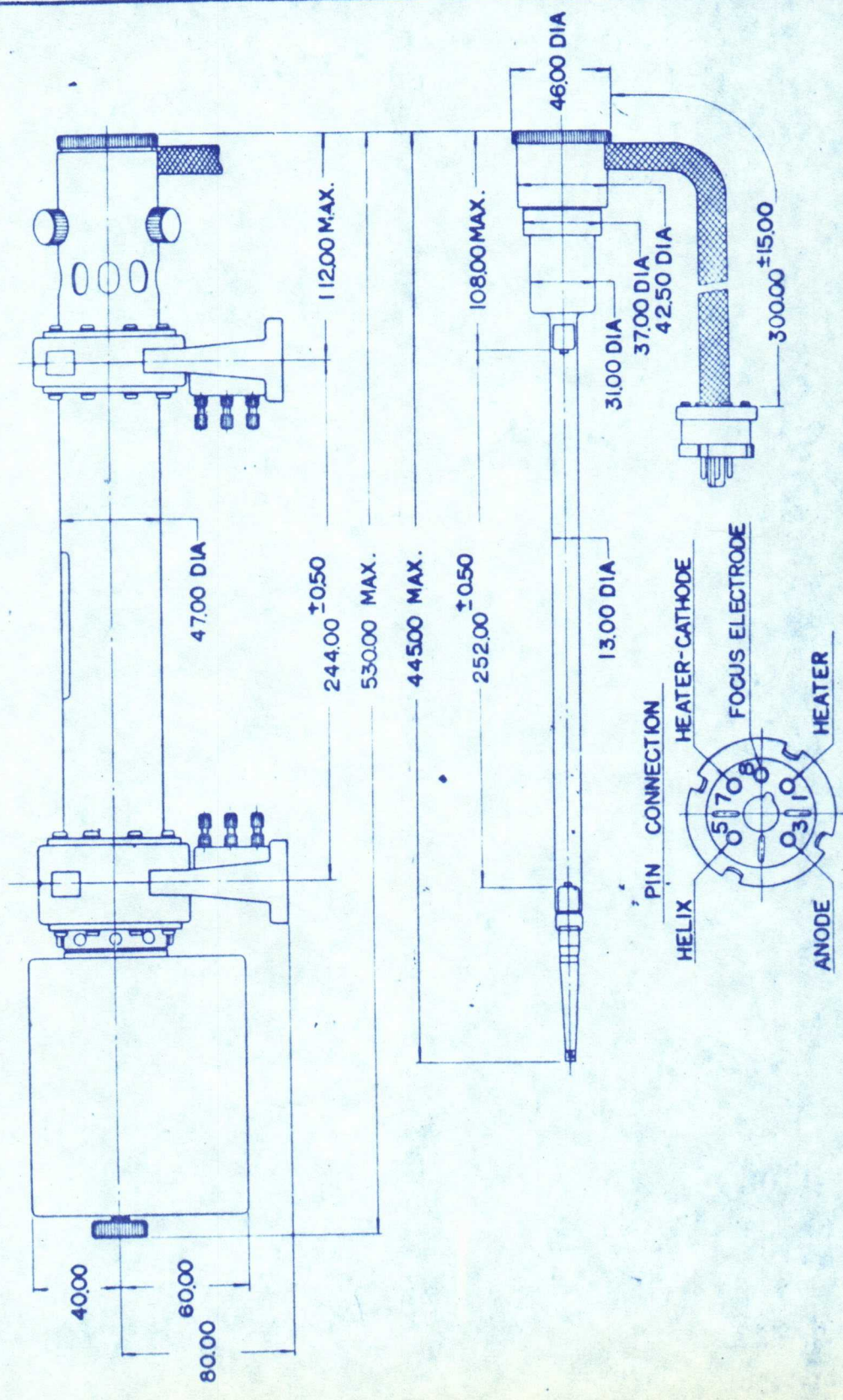

NOTES
 DIMENSIONS ARE IN MILLIMETERS.

品名	LD-597 A
材料名	真空管
所量寸度	寸
数量	1
仕上および処理	

種に規定は 普通公差とす	尺度	寸 三角法
部品名		
仕様番号		
組立図番		
SB-67290		

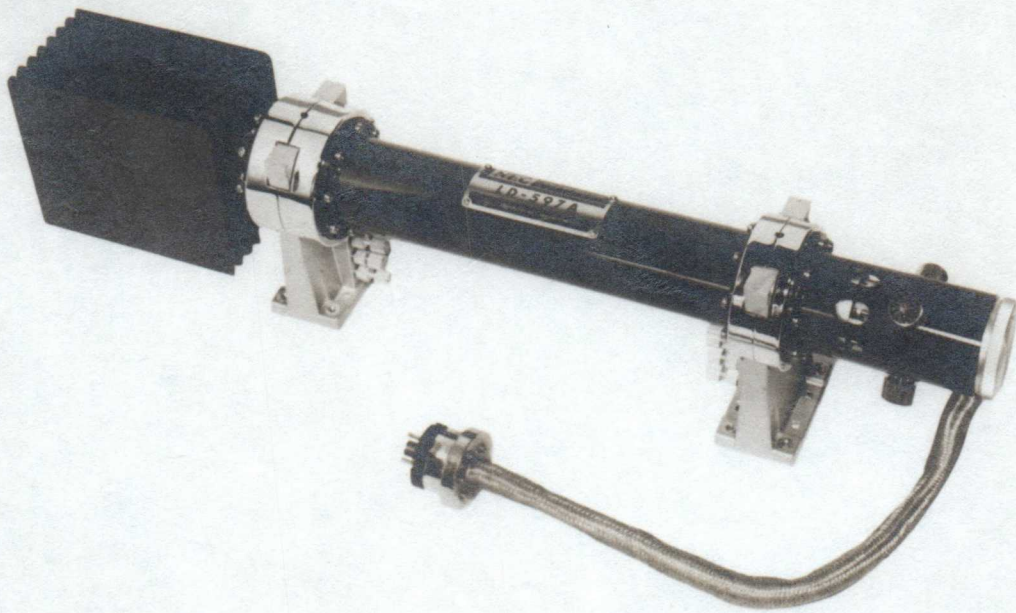

TP-42401

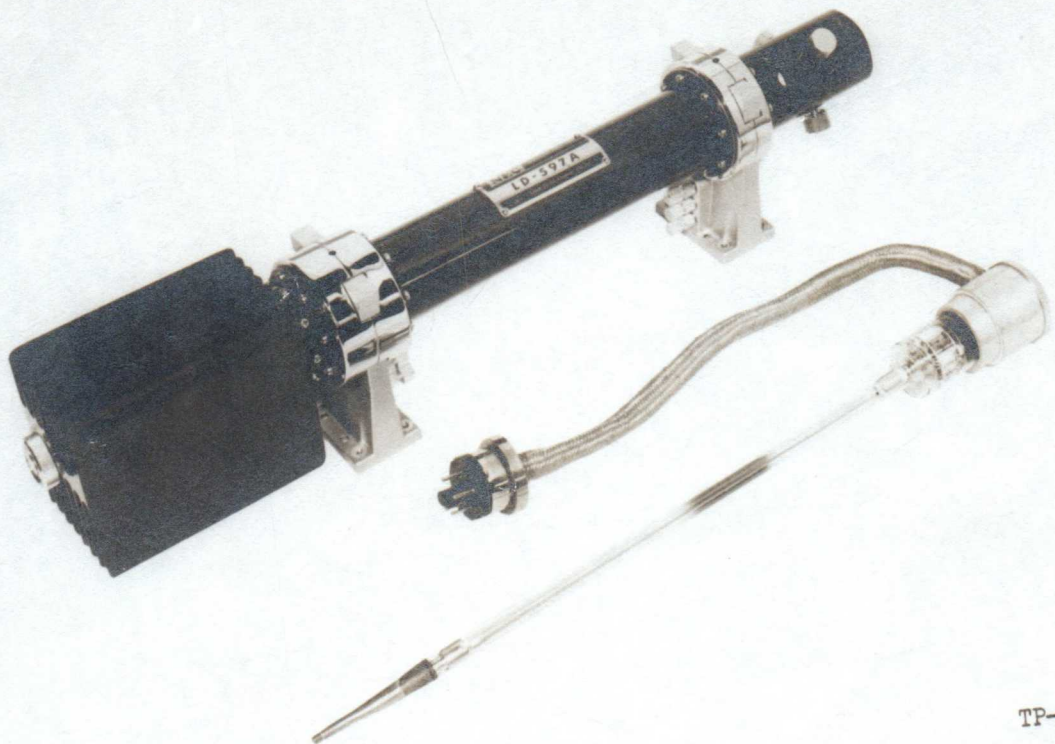

TP-42406

Traveling Wave Tube LD-605

Preliminary Data Sheet

The LD-605 is a CW traveling wave tube for operating over the frequency range of 5.85 kMc to 7.2 kMc. For the frequency band of 5.85 kMc to 6.45 kMc, this tube type has an average gain of 40 db at 10 watt output level and a saturated output power of about 20 watts. For the frequency band of 6.45 kMc to 7.2 kMc, the average gain at 10 watt output level is 38 db and the saturated output power is about 17 watts.

It is recommended that the tube be operated in the periodic permanent magnet focusing mount, type LD-605 Mount, incorporated with waveguide input and output connections fitted with matching devices. The collector electrode is depressed to 2 KV and convection cooling is usually adequate when the mount is fixed with the axis horizontal and air can circulate freely past the radiator. Forced air cooling is required if the ambient temperature exceed 55°C or the mount axis is vertical.

Tubes are fully interchangeable in the approved mount and tube replacement is a relatively simple operation.

Features

1. PPM Focused and Field Replaceable.
2. Depressed Collector Operation for Improved Efficiency.
3. Conduction and Natural Convection Cooling.

General DataPhysical

Dimensions	See Outline
Weight	Tube Envelope : 0.25 kg (0.55 lb) LD-605 Mount : 4.3 kgs (9.5 lbs)
Preferred Mounting Position	Horizontal
Cathode	Oxide Coated, Unipotential
R. F. Connections (on LD-605 Mount)	WR-137 with UG-344/U Flange

Electrical

<u>Maximum Ratings (Note 1)</u>	Min.	Max.
Collector Voltage (Eb)	1900 Vdc	2100 Vdc
Collector Current (Ib)	—	40 mAdc
Helix Voltage (Ew)	3000 Vdc	3600 Vdc
Helix Current (Iw)	—	2.0 mAdc
Accelerating Anode Voltage (Ea)	—	3600 Vdc
Accelerating Anode Current (Ia)	—	1.0 mAdc
Focusing Electrode Voltage (Ec)	-60 Vdc	-20 Vdc
Collector Dissipation	—	84 W
Collector Seal Temperature	—	130 °C
Mount Ambient Temperature Range	-10 °C	+55 °C
Cathode Heating Time	90 sec.	—

Typical Operation

Cold input and output match over 5.85 to 6.45 and 6.45 to 7.2 kMc band	VSWR < 1.3
Hot input match over 5.85 to 6.45 and 6.45 to 7.2 kMc	VSWR < 1.4
Hot output match over 5.85 to 6.45 kMc	VSWR < 1.5
Hot output match over 6.45 to 7.2 kMc	VSWR < 2
Heater Current at 6.3 Volts	0.6 A

Frequency (kMc)	5.85	6.45	7.2
Eb (Vdc)	2000	2000	2000
Ib (mAdc)	40	40	40
Ew (Vdc)	3220	3150	3130
Iw (mAdc)	0.15	0.13	0.06
Ea (Vdc)	2600	2600	2600
Ia (mAdc)	0.005	0.005	0.005
Ec (Vdc)	-35	-35	-35

RF Output Power (W) (1mW input level)	12	10	7
RF Saturated Output Power (W) (E_w /Max. P_o)	23	19	16
Small Signal Gain (db) (0.1 mW input level)	42	41	40
Noise Figure (Note 2) (db) (Small Signal)		21.3

Note 1 Ratings should not be exceeded under continuous or transient conditions. A single rating may be the limitation and simultaneous operation at more than one rating may not be possible. Equipment design should allow for voltage and environmental variations so that ratings will never be exceeded.

Note 2 This noise figure is measured by signal generator method at 6320 MC.

Operating Instruction

The following instructions provide the basic information for installing and operating the LD-605 traveling wave tube.

1. Installation of LD-605 Mount

The optimum arrangement for installation of the Mount is to provide a mounting clamp in the center of the mount between the two waveguides and then use flexible waveguides for the input and output connectors.

A satisfactory alternative arrangement is to use a fixed waveguide for the output connector, supporting the mount at this point, and then use a flexible waveguide for the input connector. Rigid waveguides may also be used providing the mechanical line-up of the waveguides is adjustable to the extent that excessive pressure is not applied to the tube flanges when the flange bolts are tightened into position.

2. Stray Magnetic Field

There is a small stray magnetic field external to the tube mount. Magnetic materials should not be kept a minimum of 0.5 inch from any portion of the tube mount except the radiator and metal cap ends of the tube envelope. Isolators should be located at spots suitable for avoidance of any influence on the tube current transmission. It is desirable to keep the increase of helix current due to other magnetic materials less than 0.1 mA.

3. Mounting Tube Envelope

Undo tube envelope positioning screws three on each side, and insert tube envelope into the mount so that the shielded flying leads fit into the notch provided in the mount, and set the envelope firmly in place by use of the clamping nut on the radiator. Care should be taken to avoid radial force.

4. Impedance Matching

Adjust the input and output plungers. Then adjust the impedance matching screws for a minimum cold VSWR.

A cold VSWR of less than 1.1 to 1 will be attained over 30 MC band from 5.85 to 7.2 kMc.

5. Applications of Voltage

- 5.1 Apply the heater voltage and allow a minimum warm-up period of 90 seconds.
- 5.2 Set the focusing electrode, collector and helix voltages according to the instructions on Test Performance Sheet accompanied by each LD-605 tube envelope shipped.
- 5.3 Switch on all voltages. Accelerating anode voltage should be about 1500 volts.
- 5.4 Adjust tube position carefully to optimize current transmission by observing the helix current.
- 5.5 Apply the specified rf drive and adjust accelerating anode voltage until the rated collector current is reached, keeping the helix voltage at the value specified on the Test Performance Sheet.

- 5.6 Adjust the helix voltage for optimum operation. The helix voltage should never be made to exceed 3600 volts or fall below 3000 volts. If the helix voltage is above or below this range, the tube may be damaged by poor current transmission. The collector voltage should never be depressed below 1900 volts with respect to the cathode.
- 5.7 Readjust tube position and adjust the focusing electrode voltage for the best current transmission, and then lock the tube envelope firmly to the tube mount by envelope positioning screws.

6. Dismantling Tube Envelope

After the power source is cut off, loosen all envelope positioning screws. Turn the clamping nut on the radiator in CCW several times and pull out tube envelope carefully from the mount after clamping nut has been completely disengaged.

LD-605

Frequency - Output Power Characteristics.

Tube NO. M8-2
Collector Current 40 mA

Saturated Output Power.

$P_{in} = 10 \text{ mW}$

$P_{in} = 1 \text{ mW}$

$P_{in} = 0.1 \text{ mW}$

Frequency (KMC)

Output Power (W)

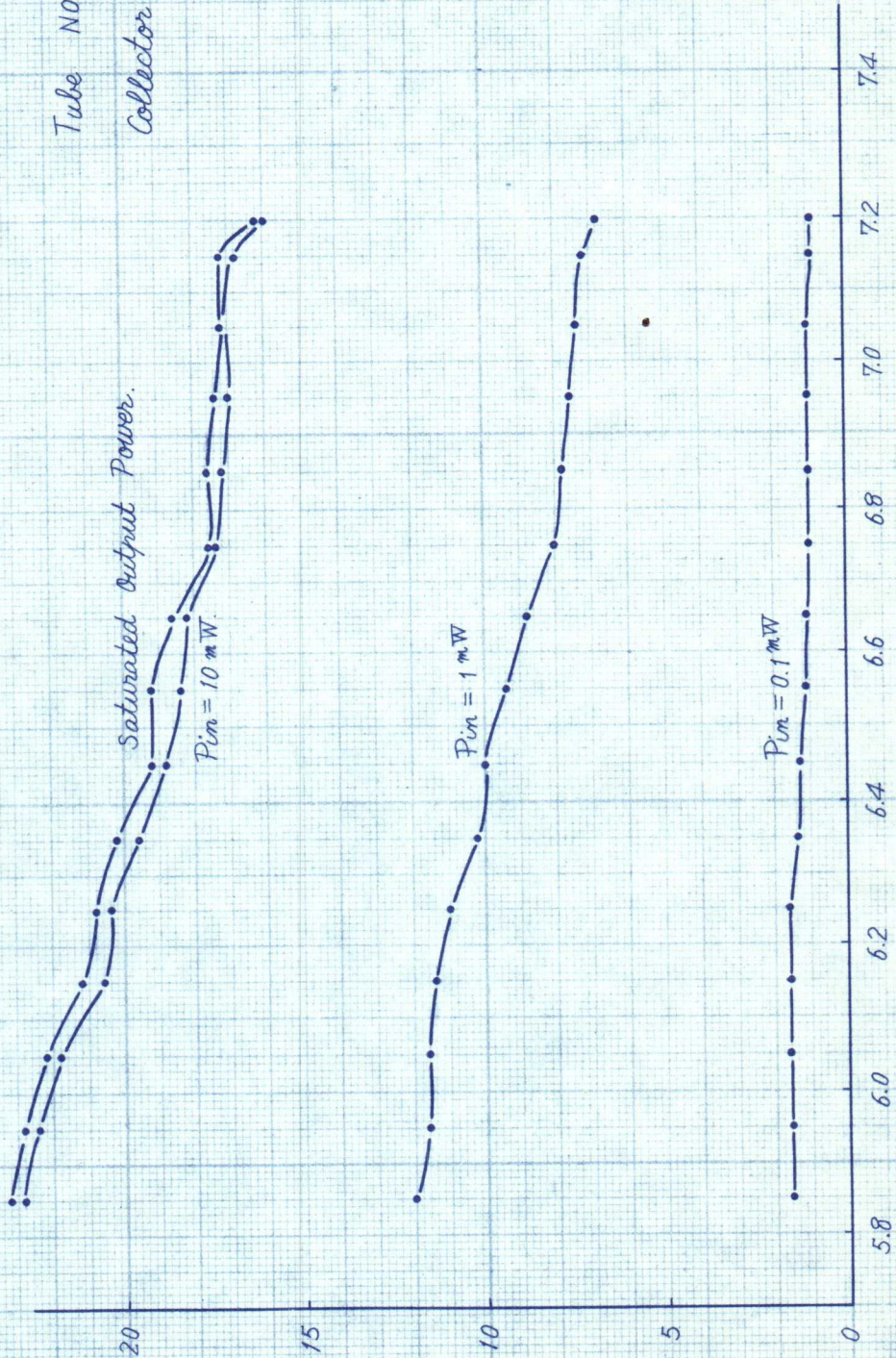

LD-605

Input Power - Output Power Characteristics

Tube NO. M8-2

Collector Current 40 mA

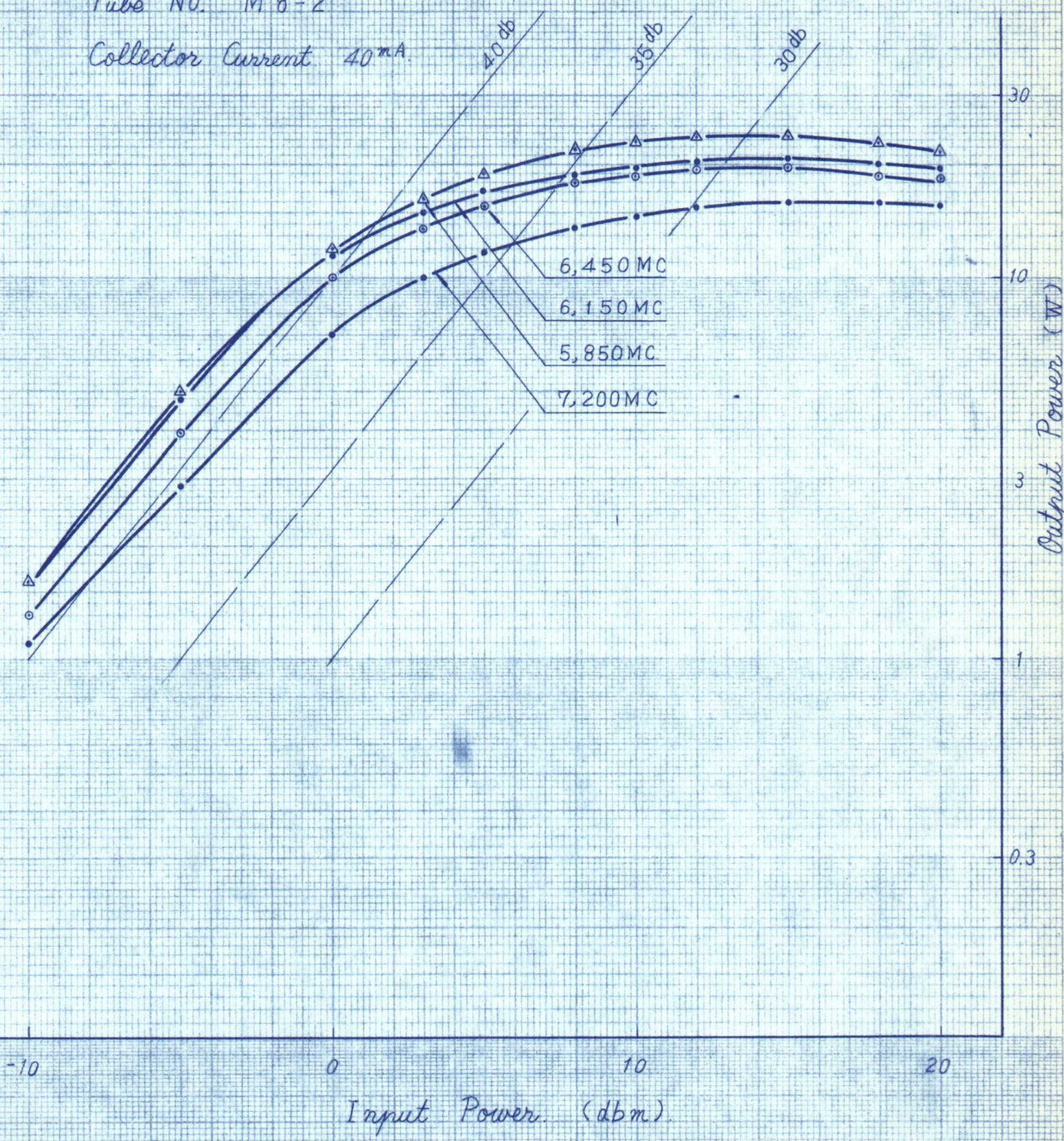

LD-605 Helix Voltage - Output Power Characteristics

Tube No. M8-2
Frequency 6,150 MC
Collector Current 40 mA

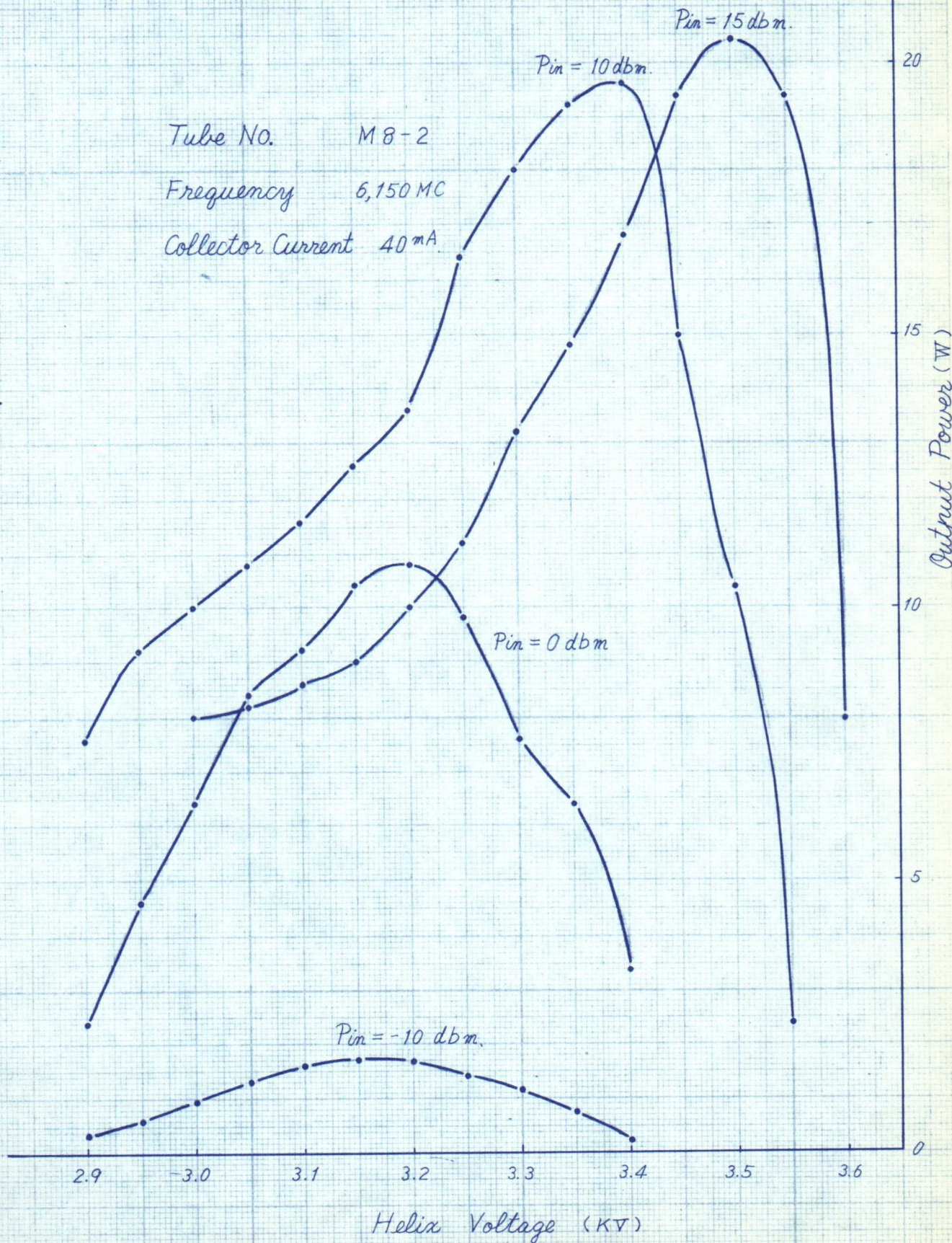

LD-605

Collector Current - Output Power Characteristics

Tube No. M8-2

Frequency 6,150 MC

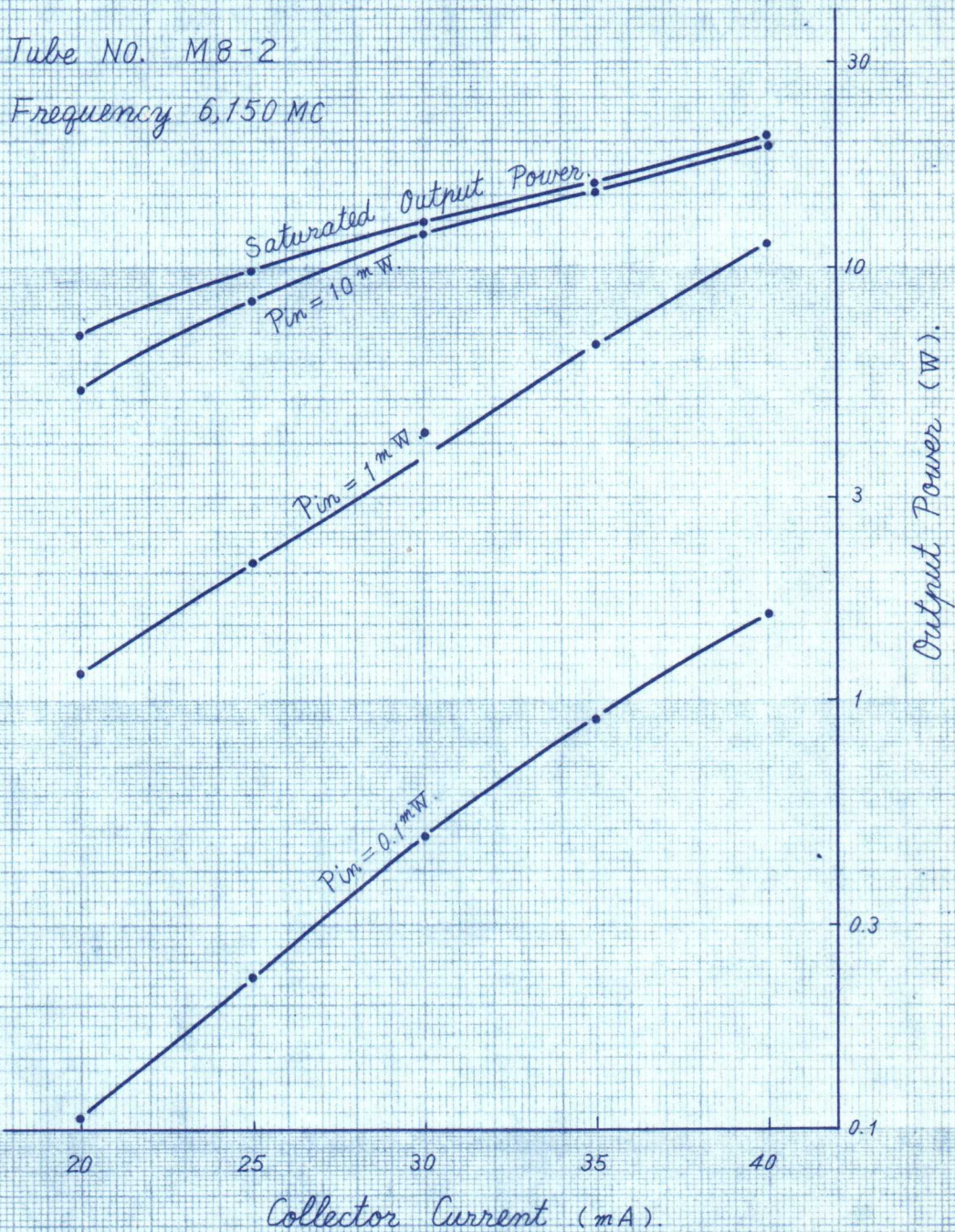

LD-605

Helix Voltage - Helix Current Characteristics.

Tube NO. M 8-2

Frequency 6,150 MC

Collector Current 40 mA

Collector Voltage 2,000 V

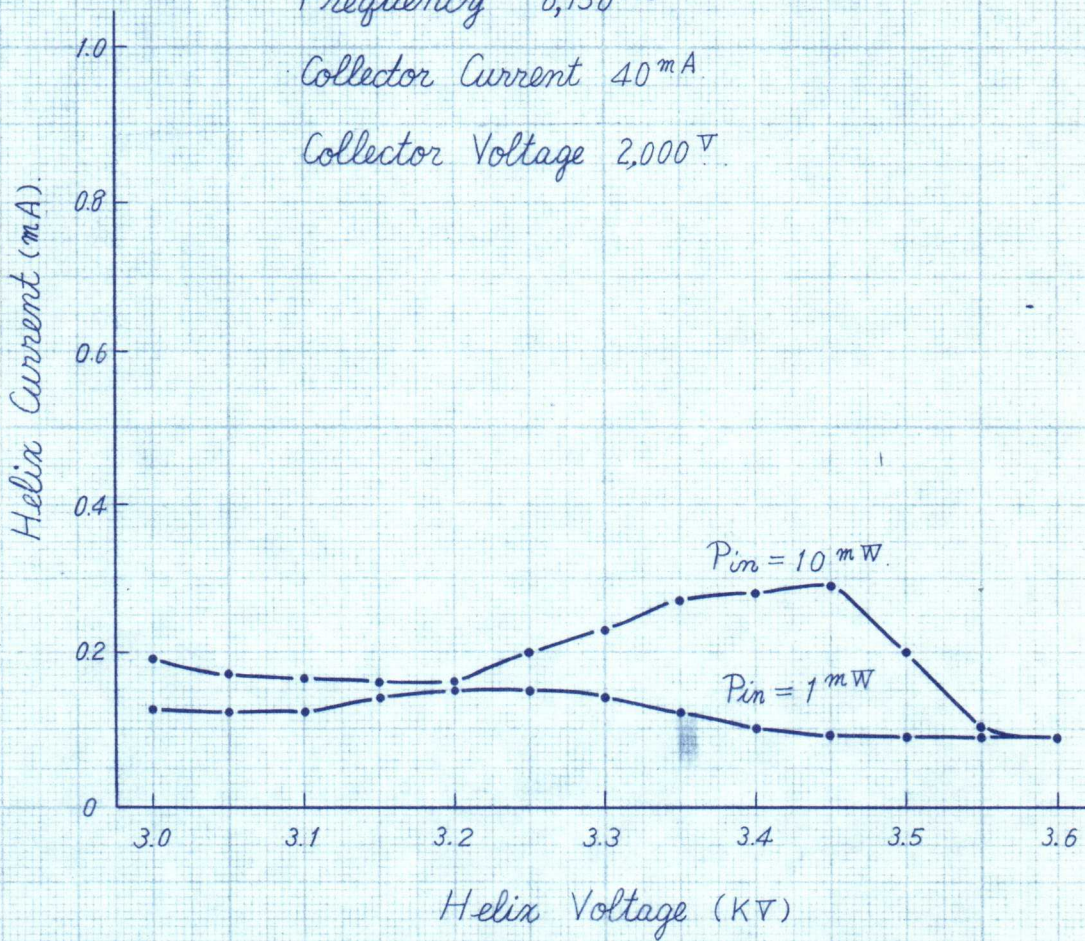

LD - 605

Helix Current - Collector Voltage Characteristics

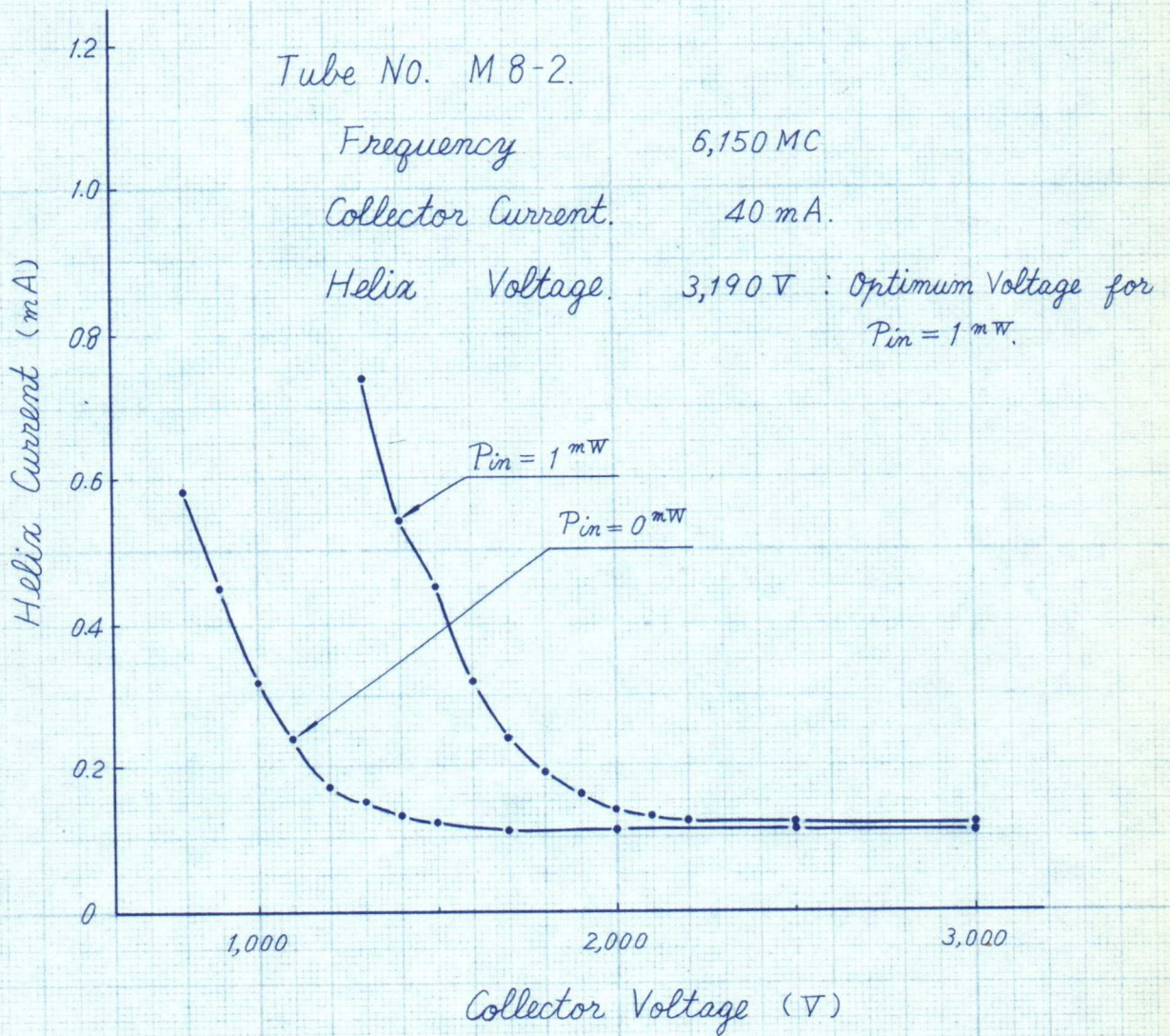

LD-605

Accelerating Anode Voltage

- Cathode Current Characteristics.

Tube NO. M8-2

Focusing Electrode Vol. -35V

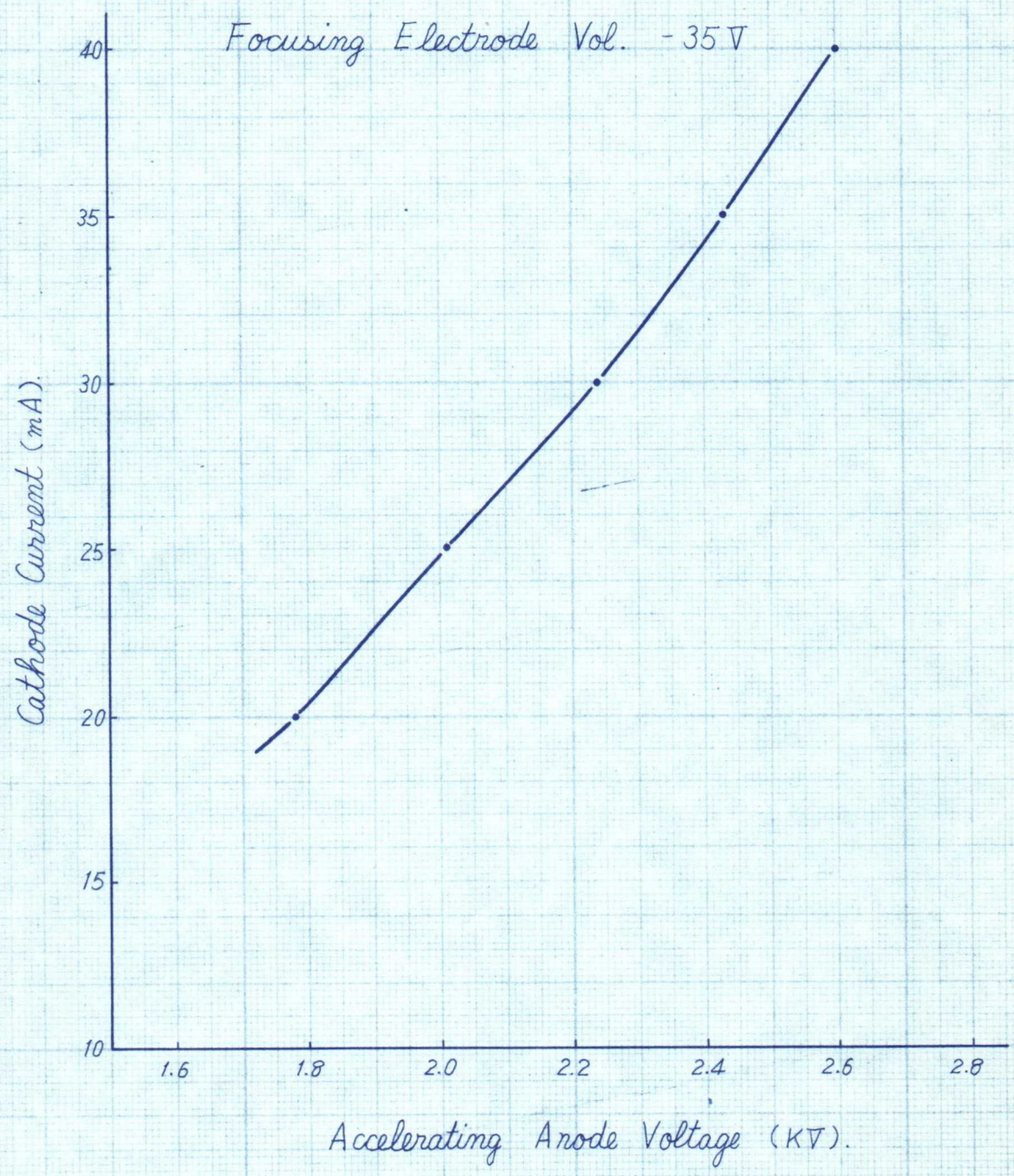

Cathode Current (mA).

Accelerating Anode Voltage (kV).

LD-605
 Frequency - VSWR Characteristics.

Tube NO. M8-2. Input Side VSWR in Cold State.

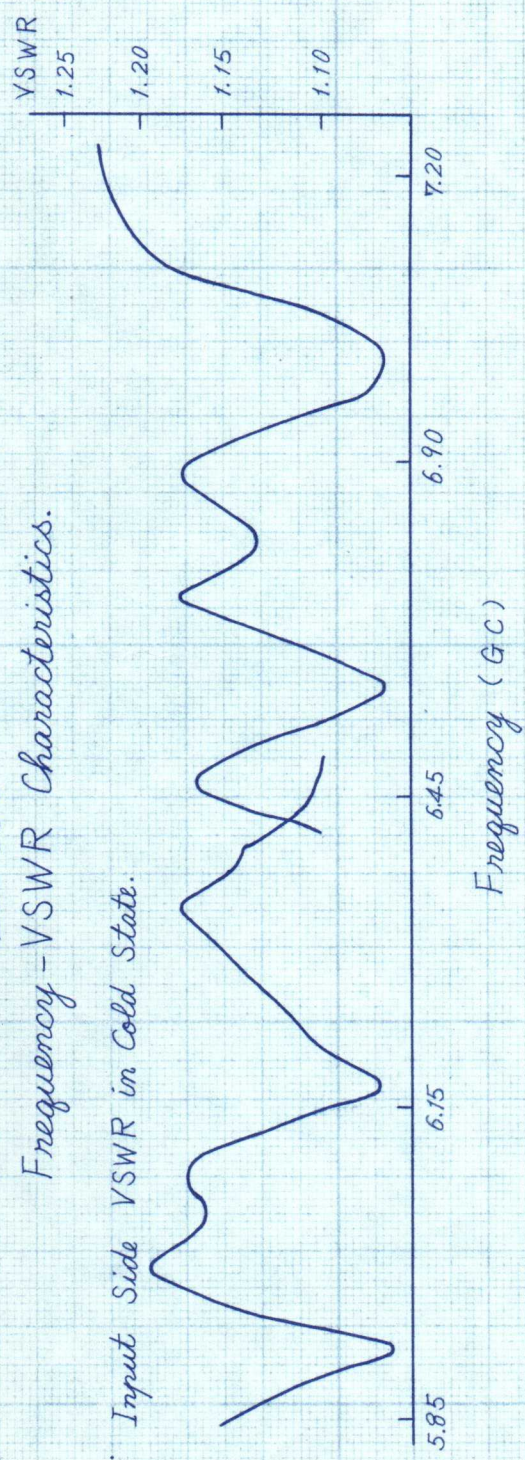

Output Side VSWR in Cold State.



類 型 番 号 日 本 電 氣

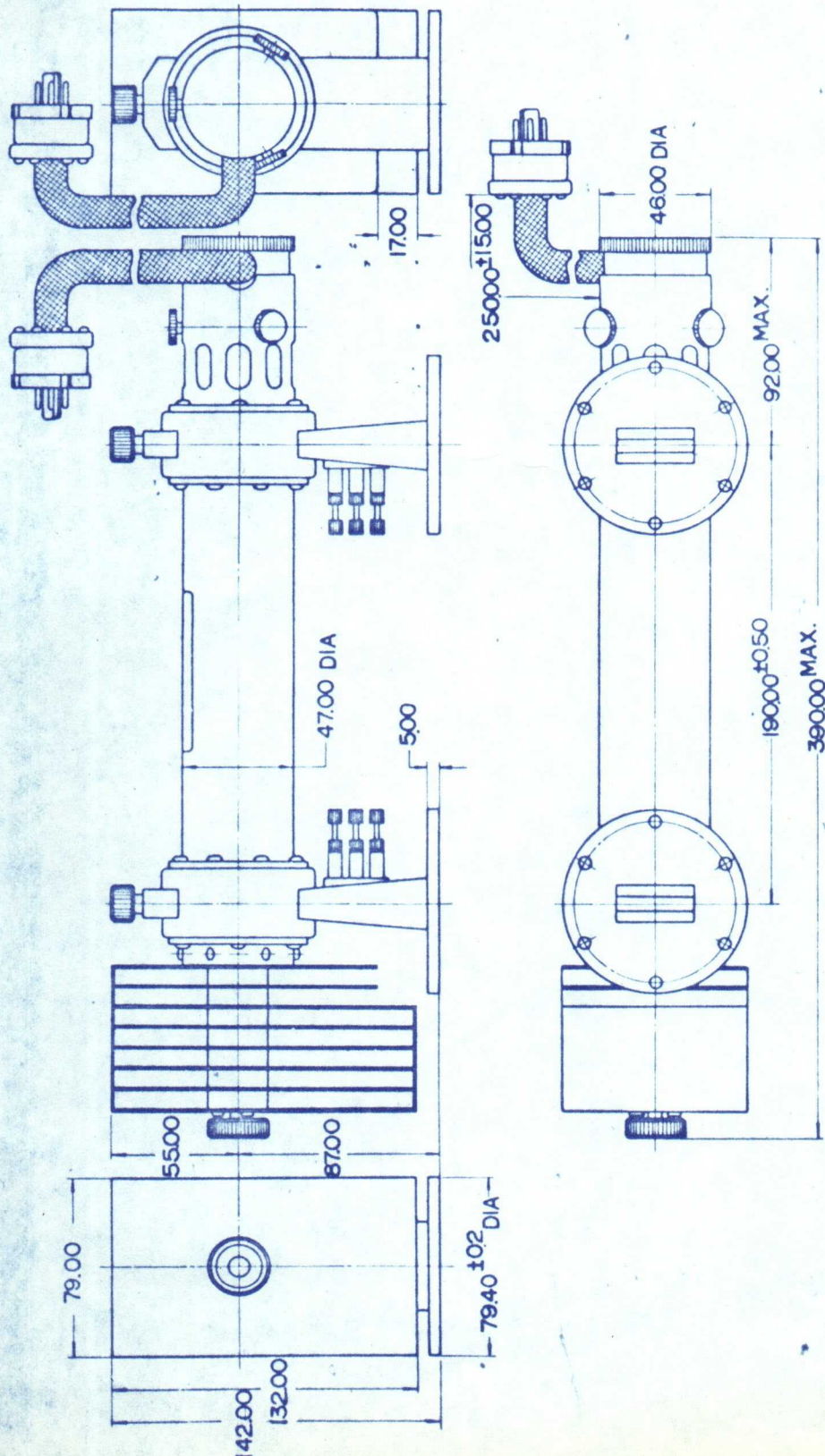

NOTES
DIMENSIONS ARE IN MILLIMETERS.



仕上および処理

LD-605
OUTLINE DRAWING

SB-67076

特殊公差は普通公差とす	尺 度	米 三 角 法
部 品 表	仕 様 番 号	
組 立 図 番		

製 材 名	所 要 寸 度	仕 上 及 び 処 理
技 術 部 当 技 術 課 設 計 課 田 島 君	製 造 課	
田 島		

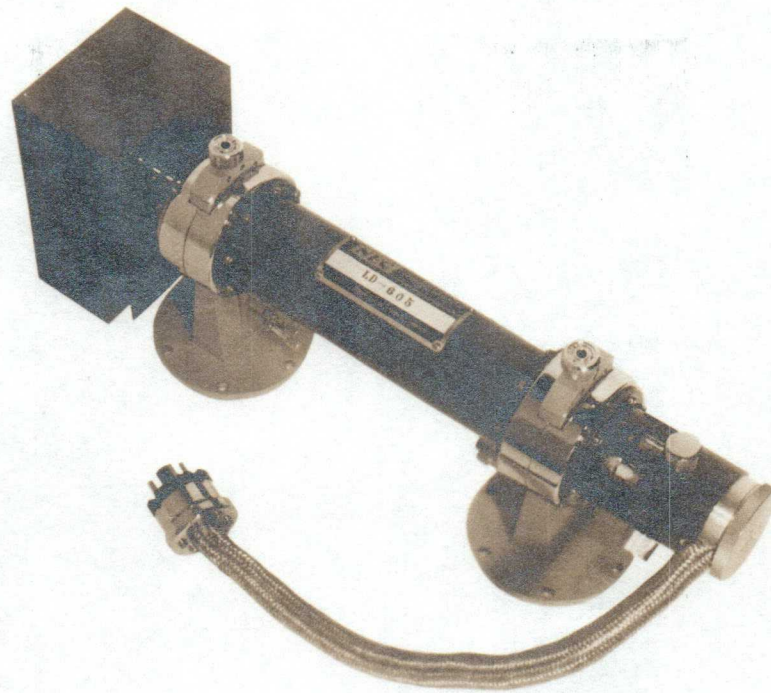

TP-40568

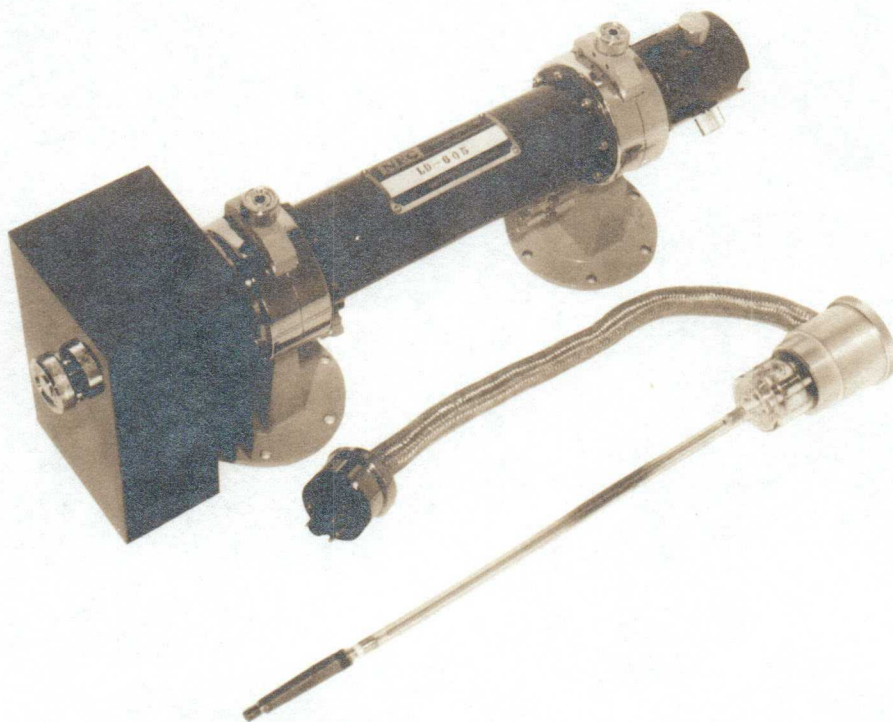

TP-40569

The LD-637 is a coaxial-type CW traveling-wave amplifier for operation over the frequency range of 1.7 to 2.3 kMc. This tube type has an average small signal gain of 30 db and a saturated output power of about 20 watts. The construction of the tube is of the conventional helical line type employing input and output N type coaxial connections. The LD-637 uses integral periodic permanent magnet focusing, and operates with a depressed collector electrode voltage. The latter feature produces a significant improvement in the operating efficiency. The design, construction and long life expectancy of the tube make it exceptionally well suited for use with transistorized communication equipments.

FEATURES

- o Depressed Collector Operation for Improved Efficiency
- o PPM Focused
- o Long Life

CHARACTERISTICS

ELECTRICAL

PHYSICAL

Maximum Ratings

General

Accelerating Voltage ... 2700V
Accelerating Anode
Current 1 mA
Helix Voltage 3000 V
Helix Current 3 mA

Dimensions See Outline
Weight 11 lbs
Mounting
Position Any

Collector Voltage, min. 1900V

Cathode Oxide coated,
unipotential

Collector Current 60 mA

Connections

Collector Dissipation 120 W

RF Input and Output ...
Coaxial type N female connectors

Focusing Electrode Voltage .. -70 V

Ambient Temperature 55°C

Cooling

Ambient Temperature, min. ... -55°C

Forced air (18 CFM)

Collector Seal Temperature .. 180°C

OPERATION

Heater Voltage = 6.3V; Heater Current at 6.3V = 1.0A

Frequency	1.7	2.0	2.3	kMc
Accelerating Anode Voltage	2500	2500	2500	V
Helix Voltage	2700	2550	2400	V
Helix Current	0.5	0.5	0.5	mA
Collector Voltage	2000	2000	2000	V
Collector Current	55	55	55	mA
RF Output (10mW input level)	9.5	10	7.5	W
RF Saturated Output	19.5	20	17.5	W
Noise Figure (small signal)	27	27	27	db
Small Signal Gain	31	32	31	db

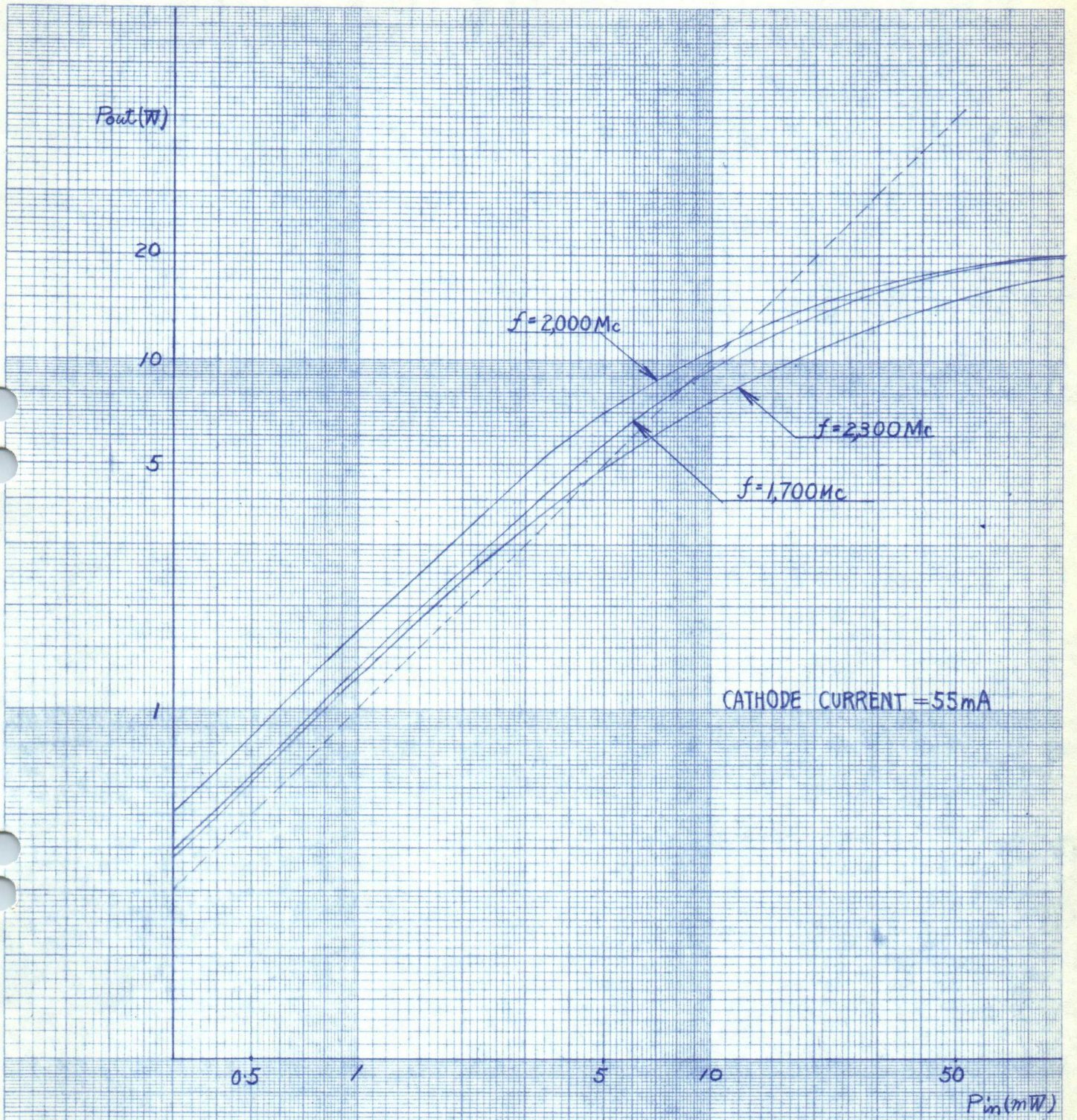

LD-637 $P_{in} - P_{out}$ CHARACTERISTICS



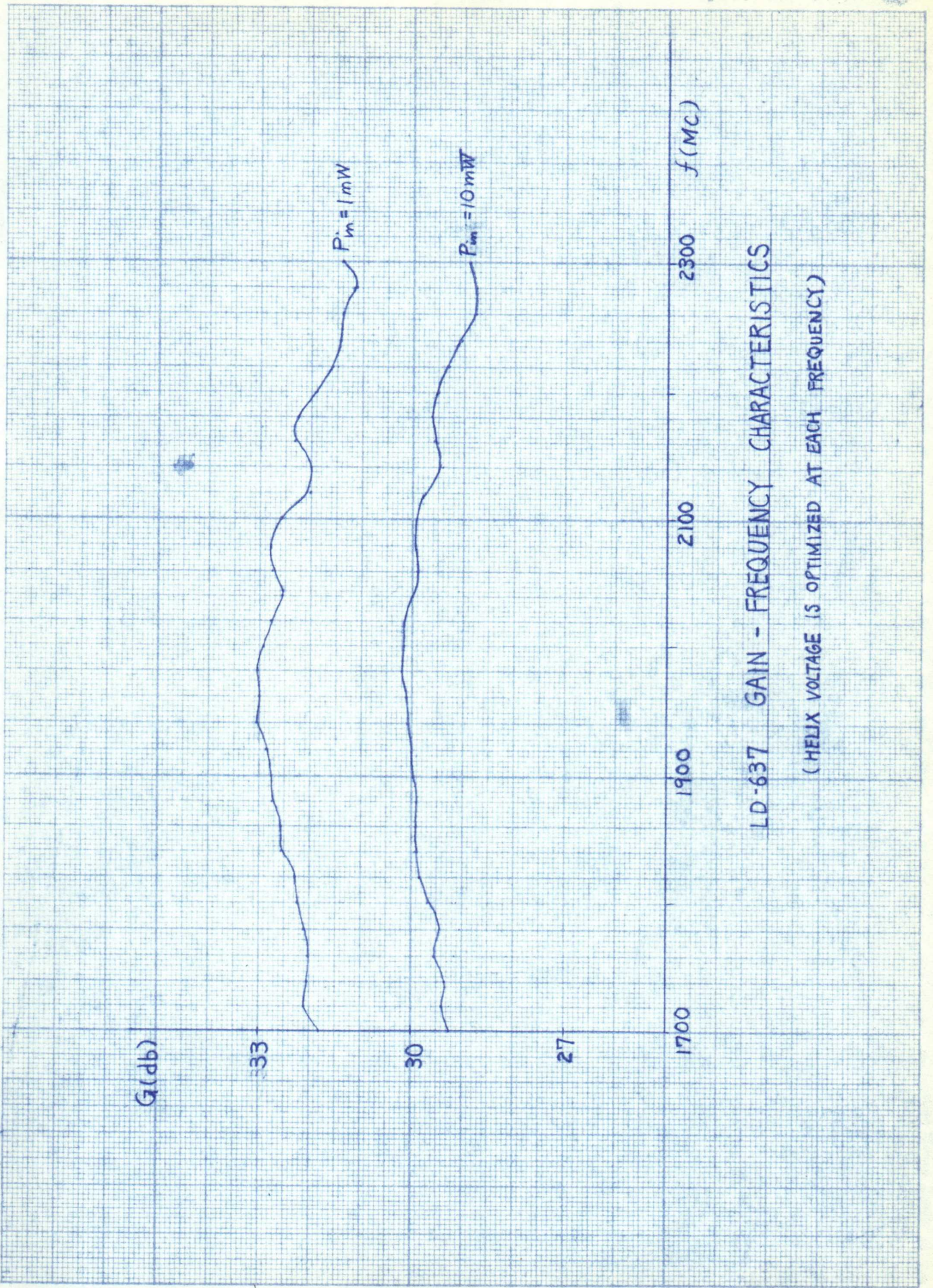

LD-637 GAIN - FREQUENCY CHARACTERISTICS

(HELIX VOLTAGE IS OPTIMIZED AT EACH FREQUENCY)

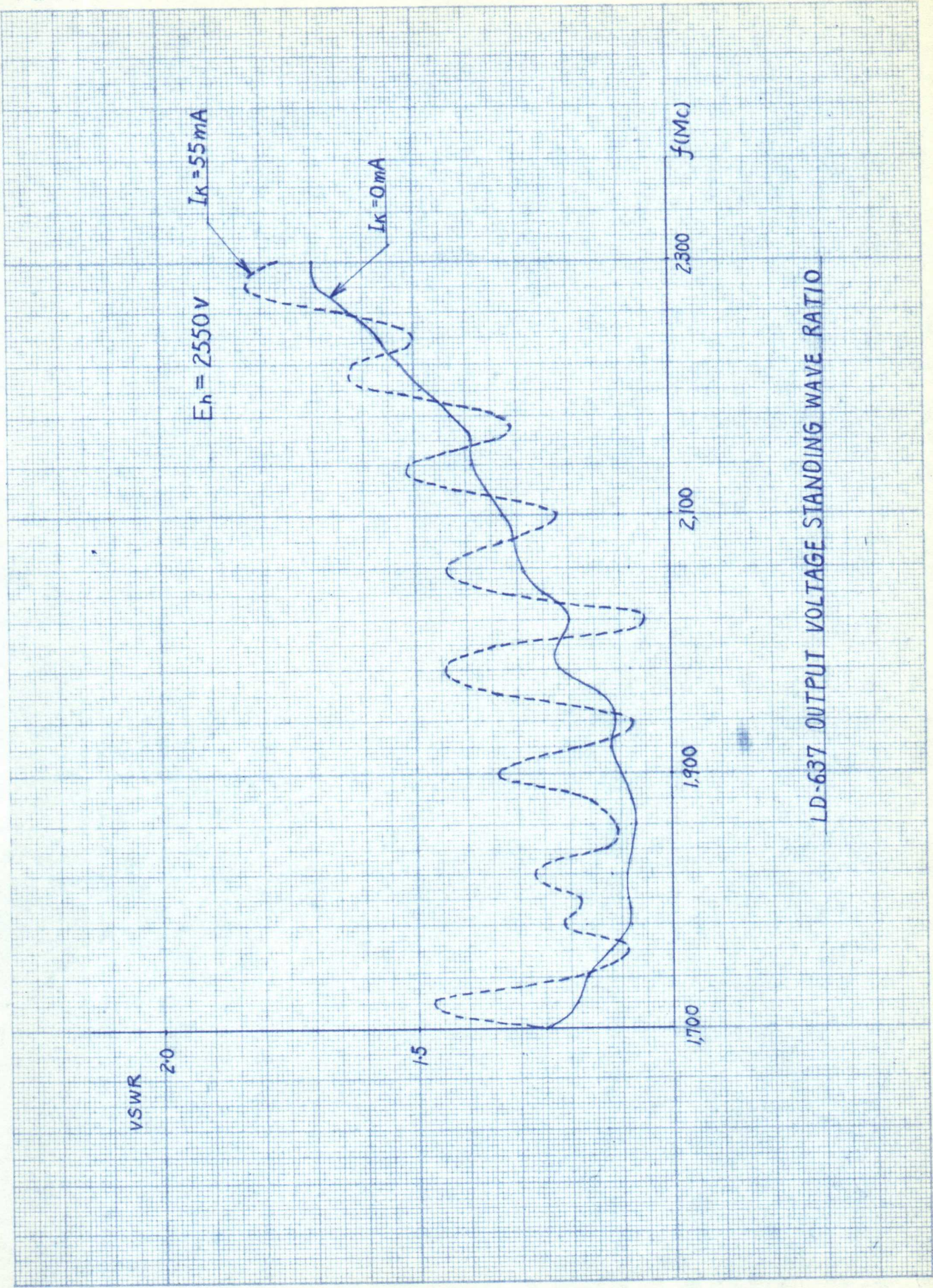

LD-637 OUTPUT VOLTAGE STANDING WAVE RATIO

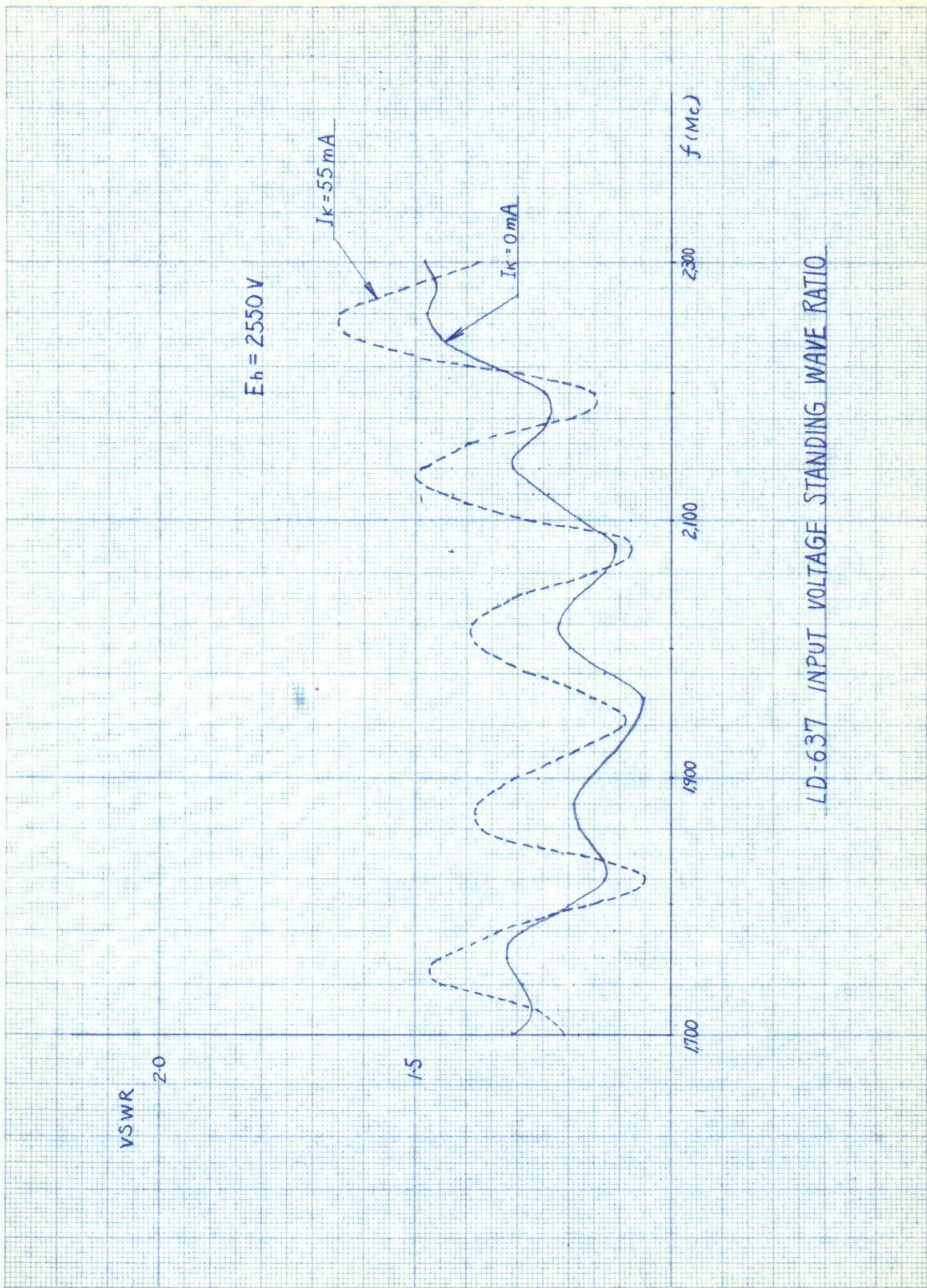

LD-637 INPUT VOLTAGE STANDING WAVE RATIO

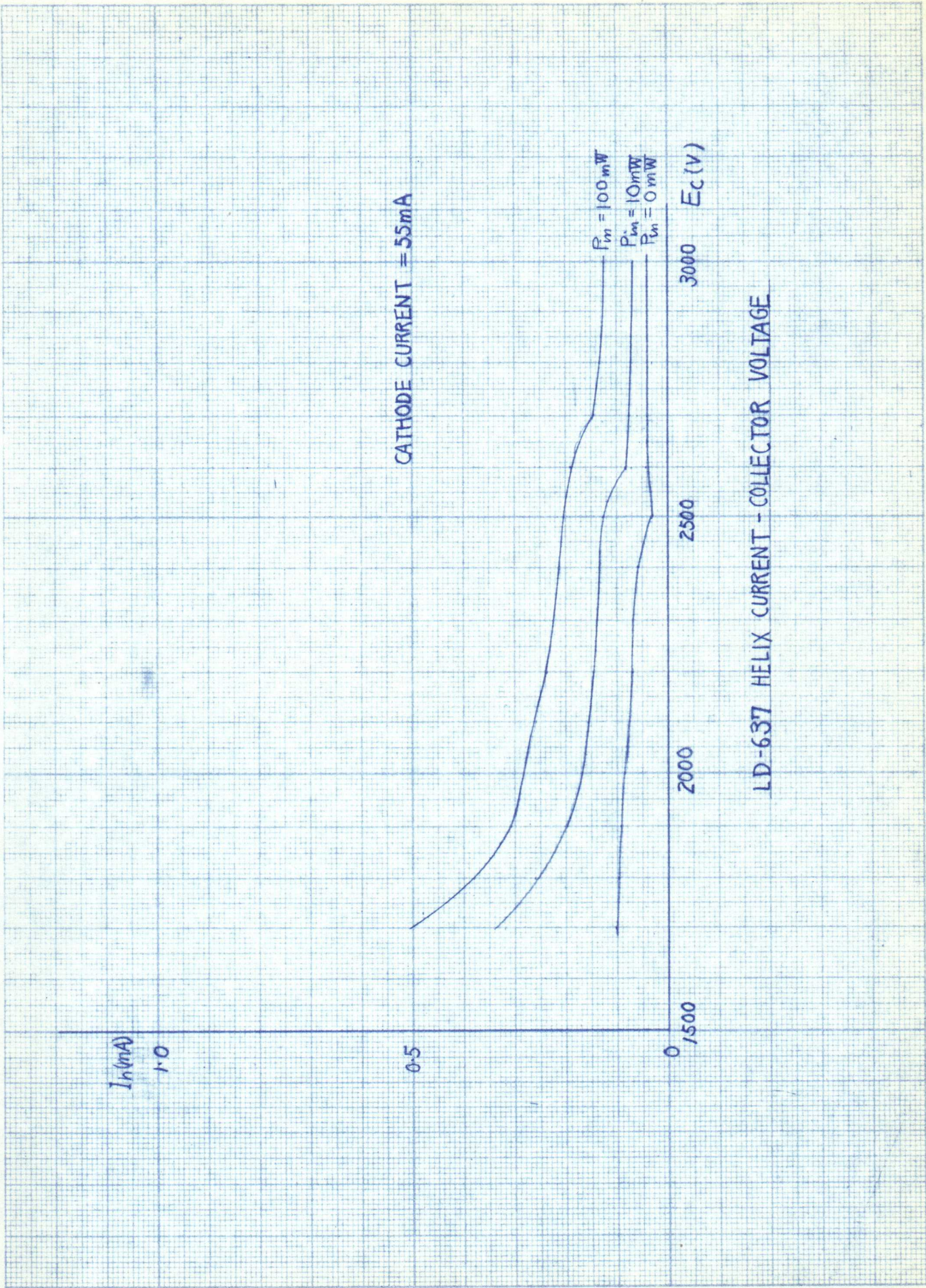

CATHODE CURRENT = 55 mA

$P_m = 100 \text{ mW}$
 $P_m = 10 \text{ mW}$
 $P_m = 0 \text{ mW}$

LD-637 HELIX CURRENT - COLLECTOR VOLTAGE

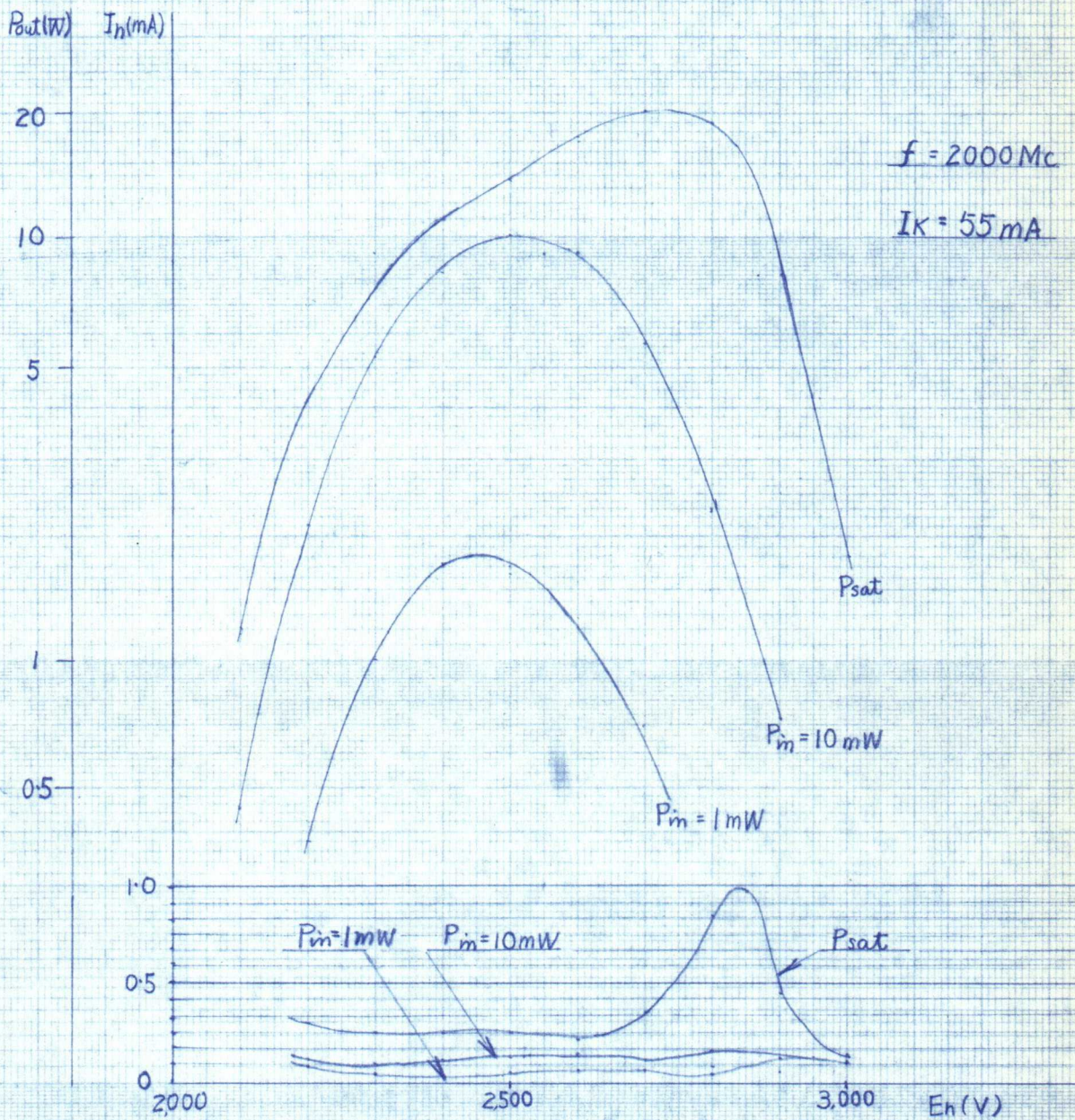

LD-637 OUTPUT POWER - HELIX VOLTAGE
 HELIX CURRENT - HELIX VOLTAGE

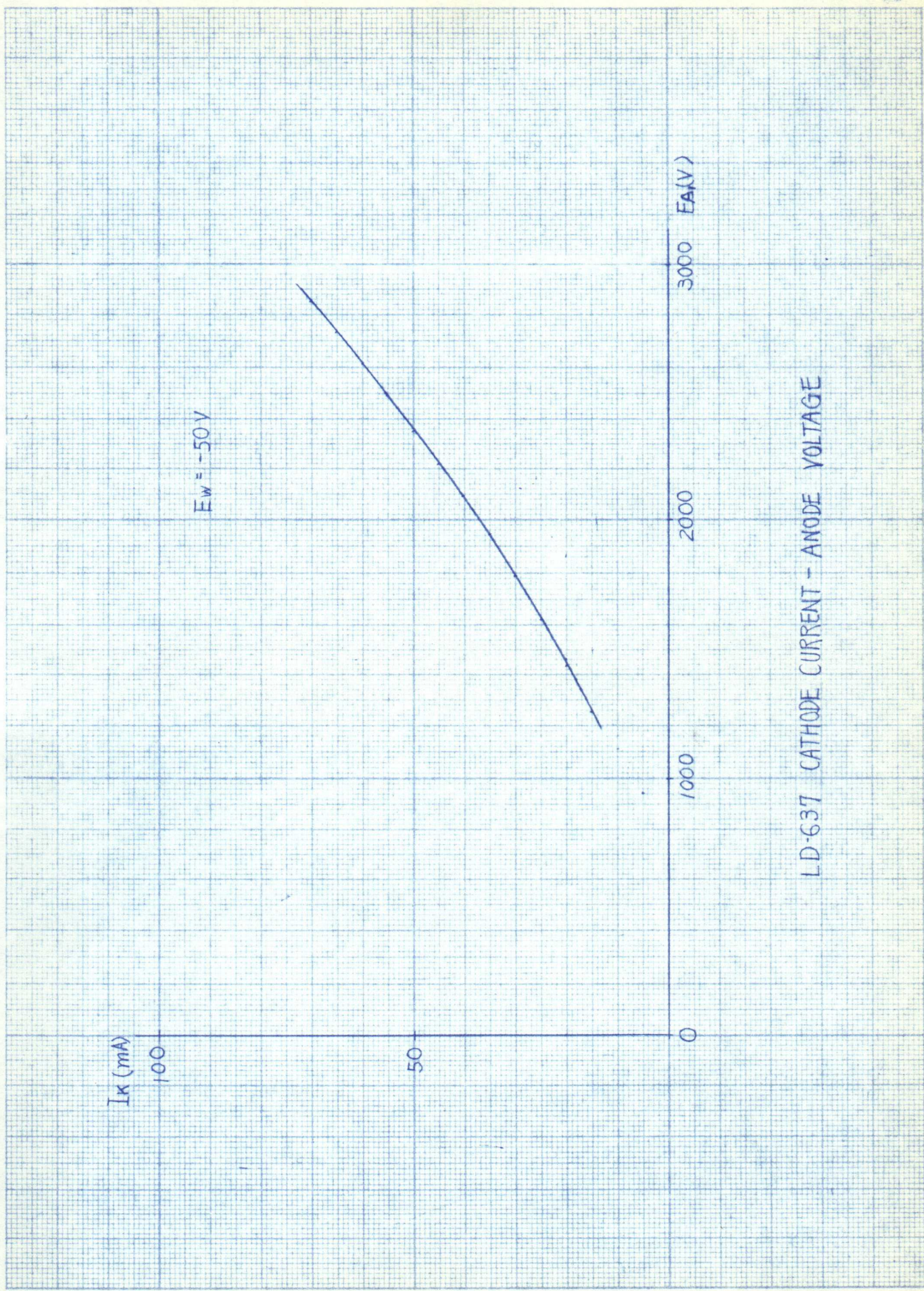

LD-637 CATHODE CURRENT - ANODE VOLTAGE

I_k (mA)

100

50

0

1000

2000

3000 E_a (V)

$E_w = -50V$

1		
---	--	--

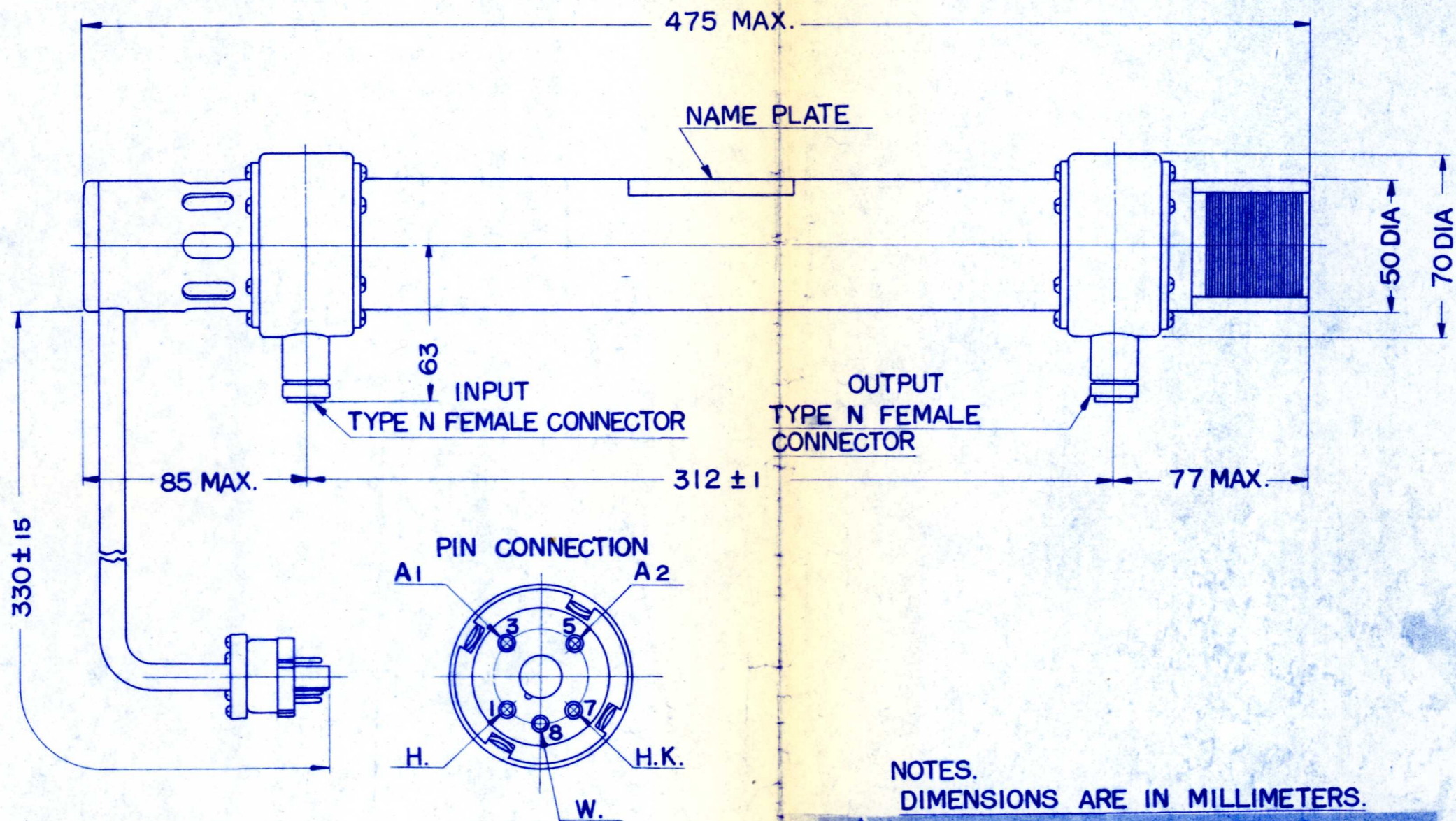

NOTES.
DIMENSIONS ARE IN MILLIMETERS.

Collector is internally connected to outer conductor of the RF connectors. Never apply high voltage to the accelerating electrode before applying earth potential to the connector.

特に指定なきは 普通公差とす	尺度 オ三角法
部品表	
仕様書番号	
組立図番	

素材名	所要寸度	仕上および処理
技術担当 y. Tsunoyama	技術承認 S. Yamada	設計製図 査 閱 承 認
LD-637		
OUTLINE DRAWING		

SB-67480

整理番号



TP-40565

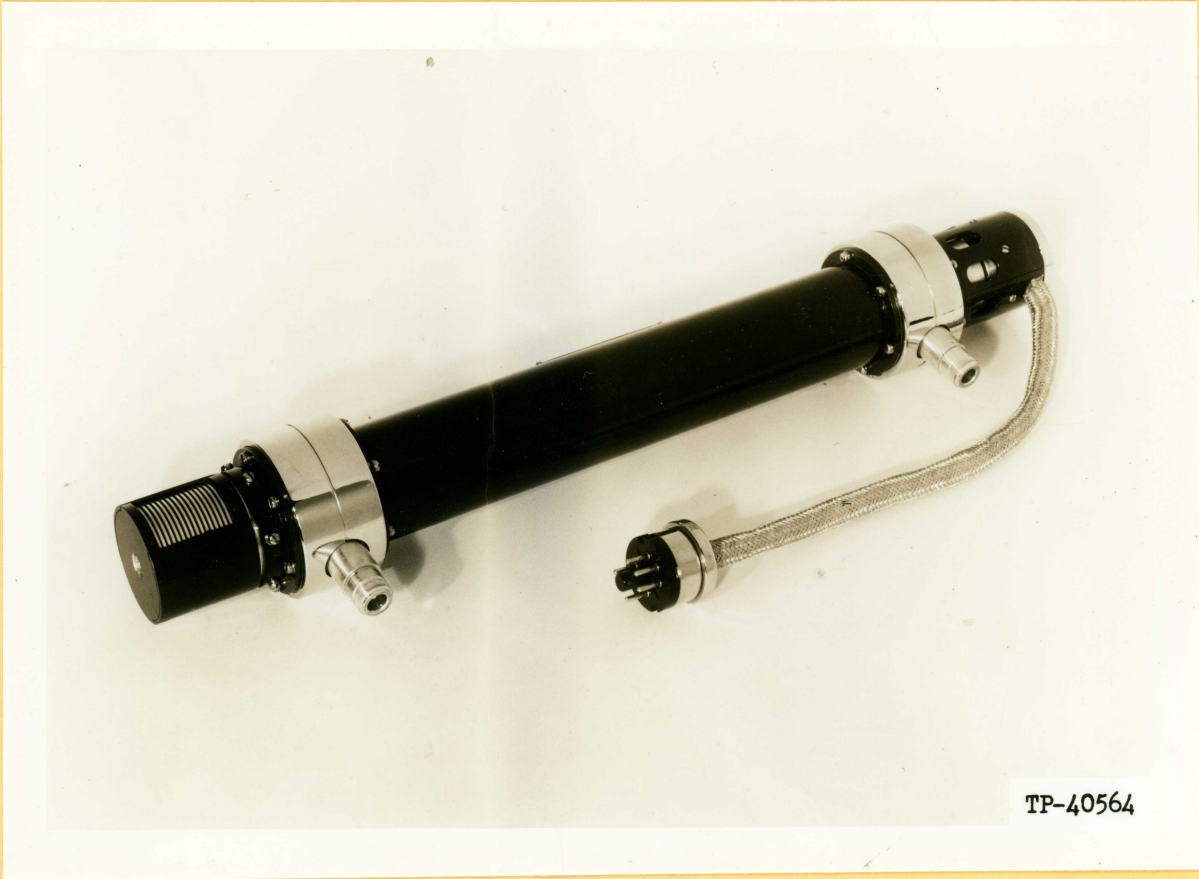

TP-40564

N E C

P 250 A

Natural Air Cooled Pentode

Power Amplifier, Oscillator, Modulator, or Grid No.3
Modulator, frequency up to 25 MHz.

Electrical Data:

General Data:

Filament: Thoriated Tungsten

In Case of Single Phase Heating:

Voltage	12	Volts
Current (at nominal voltage)	8.5	Amps

In Case of Two Phase Heatings:

Voltage	6	Volts
Current (at nominal voltage)	17	Amps

Transconductance	8	Milliamps
(for $E_b=2000Vdc$, $E_{c3}=0Vdc$, $E_{c2}=500Vdc$, $I_b=210mAde$)		

Amplification Factor, Grid No.1 to Grid No.2	6.5	
(for $E_b=2000Vdc$, $E_{c3}=0Vdc$, $E_{c2}=500Vdc$, $I_b=210mAde$)		

Direct Interelectrode Capacitances

Grid No.1 to Plate	0.16	μF
Input	34	μF
Output	24	μF

Frequency for max. Ratings	25	MHz
----------------------------------	----	-----

Mechanical Data:

Dimensions:

Maximum overall Length	238	mm
Maximum Diameter	123	mm
Net Weight (approx.)	990	g

Base:

Upper JIS A20S
 Bottom JIS F65S
 Socket NEC M-103
 Cap NEC VT-309

Terminal Connections:

1: Grid No.2	5: Filament
2: Filament Common Point	6: Grid No.1
	G ₃ : Grid No.3(upper base)
3: Grid No.3	P: Plate (upper base)
4: Filament	

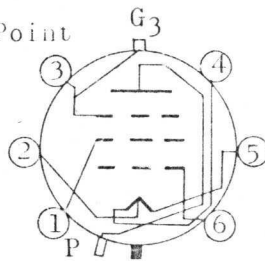

Mounting Position: Vertical, Bottom Base Up or Down.

Cooling: Convection and Radiation

Maximum Bulb Temperature 200°C
 Maximum Upper Base Temperature 180°C
 Maximum Bottom Base Temperature 170°C

AF Power Amplifier and Modulator-Class B

Maximum Ratings:

DC Plate Voltage	3000 Volts
DC Grid No.3 Voltage	100 Volts
DC Grid No.2 Voltage	600 Volts
Max.-Signal DC Plate Current (note 1)	500 mA
Max.-Signal Plate Input (note 1)	1000 Watts
Plate Dissipation (note 1)	420 Watts
Grid No.2 Dissipation (note 1)	70 Watts

note 1. Averaged over any audio-frequency cycle of sine-wave form

Typical Operation: (Value are for two tubes)

DC Plate Voltage	2000	2500	Volts
DC Grid No.3 Voltage	0	0	Volts
DC Grid No.2 Voltage	500	500	Volts

DC Grid No.1 Voltage	-70	-70 Volts
Peak AF Grid No.1-to-Grid No.1 Voltage	210	200 Volts
Zero-Signal DC Plate Current	160	180 mA
Max.-Signal DC Plate Current	800	800 mA
Zero-Signal DC Grid No.2 Current	4	4 mA
Max.-Signal DC Grid No.2 Current (approx.)	25	21 mA
Max.-Signal DC Grid No.1 Current (approx.)	21	17 mA
Effective Load Resistance (Plate-to-Plate)	5080	6400 Ohms
Max.-Signal Driving Power (approx.)	2.1	1.6 Watts
Max.-Signal Power Output (approx.)	1000	1200 Watts

Grid No.3 Modulated RF Power Amplifier - Class C Telephony
(Carrier conditions per tube for use with a max.
modulation factor of 1.0)

Maximum Ratings:

DC Plate Voltage	3000	Volts
DC Grid No.2 Voltage	600	Volts
DC Grid No.1 Voltage	-400	Volts
DC Plate Current	250	mA
DC Grid No.1 Current	40	mA
Plate Dissipation	420	Watts
Grid No.1 Dissipation	70	Watts

Typical Operation:

Please refer to the "grid No.3 modulated characteristics."

RF Power Amplifier and Oscillator—Class C Telephony

(Key-down condition per tube without amplitude modulation)

Maximum Ratings:

DC Plate Voltage	3000 Volts
DC Grid No.3 Voltage	100 Volts
DC Grid No.2 Voltage	600 Volts
DC Grid No.1 Voltage	-400 Volts
DC Plate Current	500 mA
DC Grid No.1 Current	40 mA
Plate Input	1500 Watts
Plate Dissipation	420 Watts
Grid No.2 Dissipation	70 Watts

Typical Operation:

DC Plate Voltage	2000	3000	Volts
DC Grid No.3 Voltage	0	0	Volts
DC Grid No.2 Voltage	500	500	Volts
DC Grid No.1 Voltage	-200	-200	Volts
Peak RF Grid No.1 Voltage	300	300	Volts
DC Plate Current	500	480	mA
DC Grid No.2 Current	44	40	mA
DC Grid No.1 Current (approx.)	20	20	mA
Driving Power (approx.)	6	6.5	Watts
Power Output (approx.)	710	1050	Watts
Load Power Output (approx.) (note 2)	630	950	Watts

note 2. The value is reduced by driving power for oscillator.

P 250A

PLATE CURRENT (I_b), GRID NO. 2 CURRENT (I_{c2}), GRID NO. 1 CURRENT (I_{c1}) IN mA

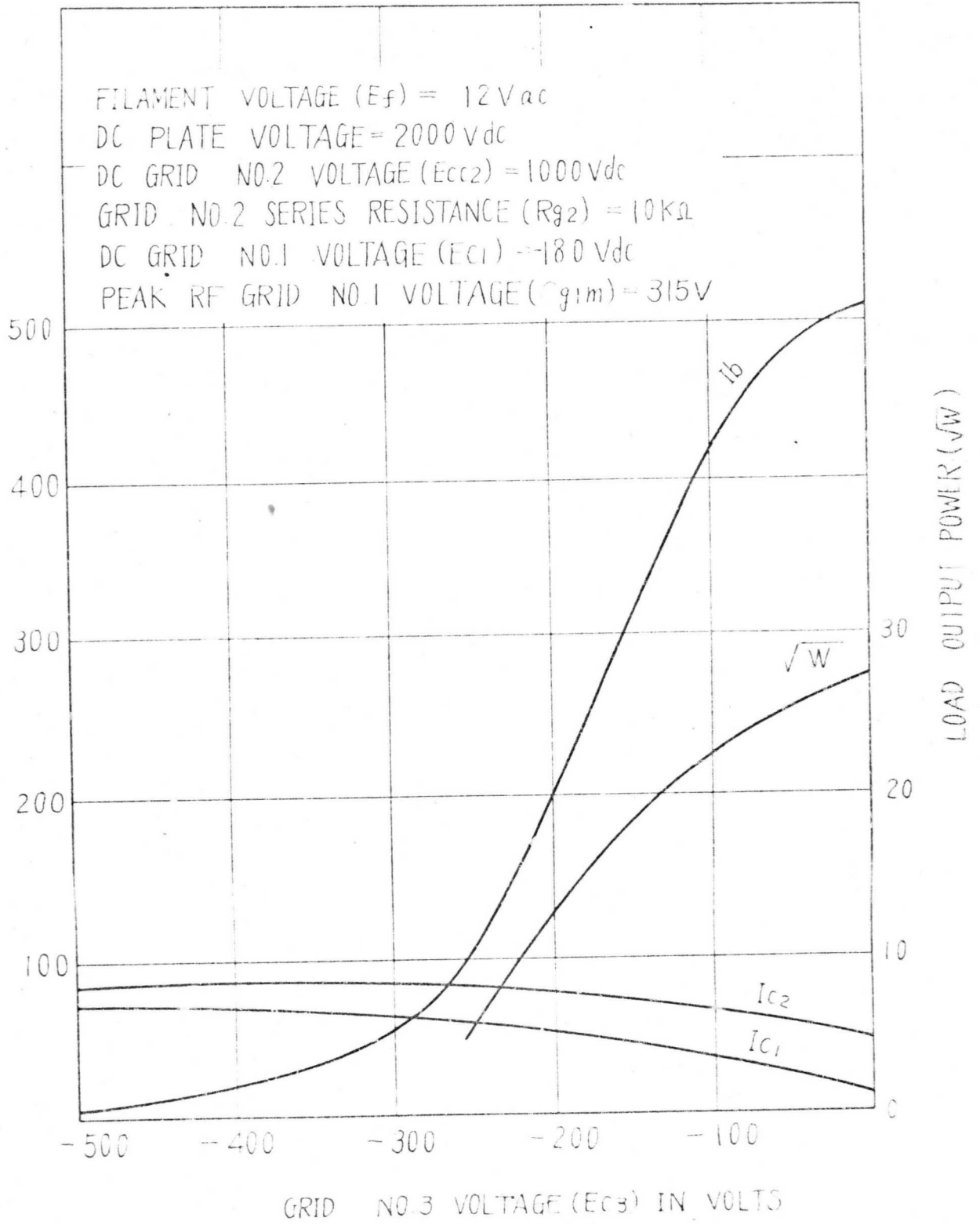

P250A GRID NO. 3 MODULATED CHARACTERISTICS

P 250A

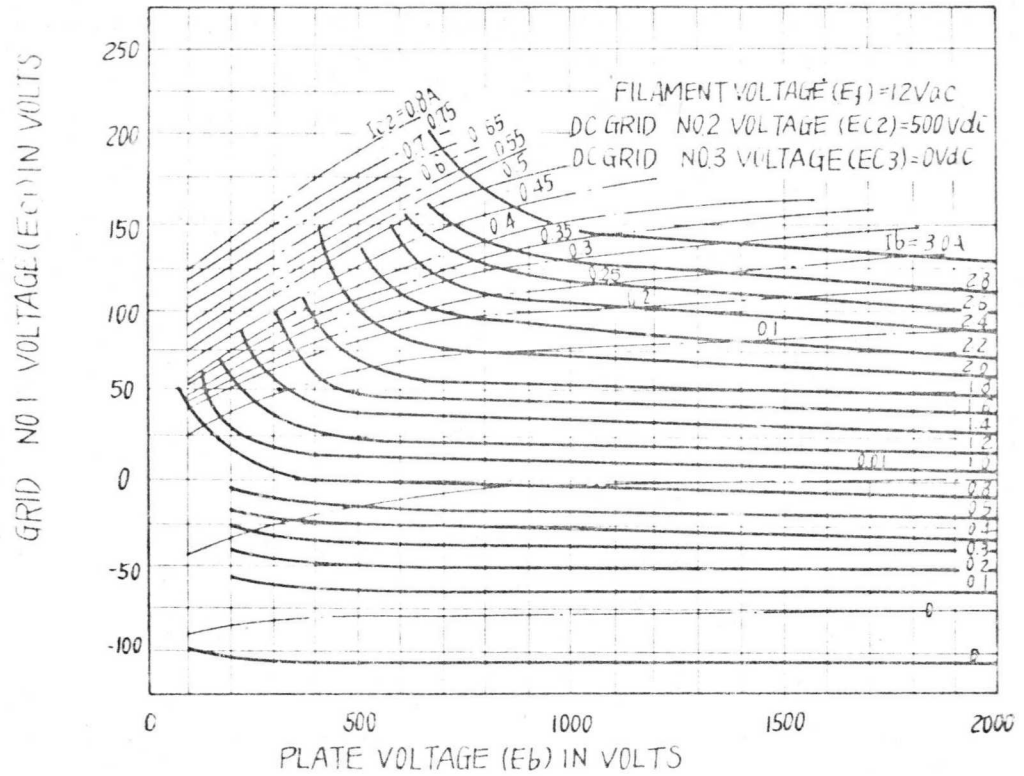

P250A CONSTANT CURRENT CHARACTERISTICS

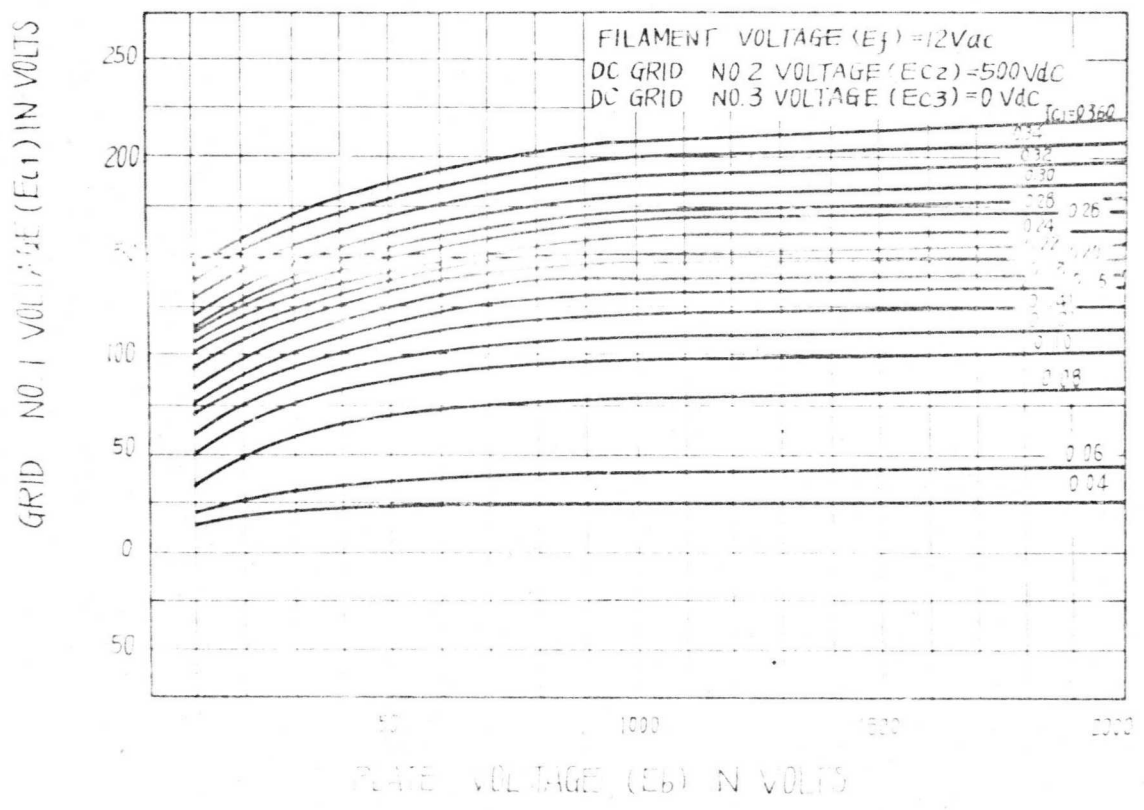

P250A CONSTANT CURRENT CHARACTERISTICS

P250A

Unit mm

