

Sieben A. 9.

PHILIPS

Data handbook



Electronic
components
and materials

Electron tubes

Part 5a August 1976

Cathode-ray tubes

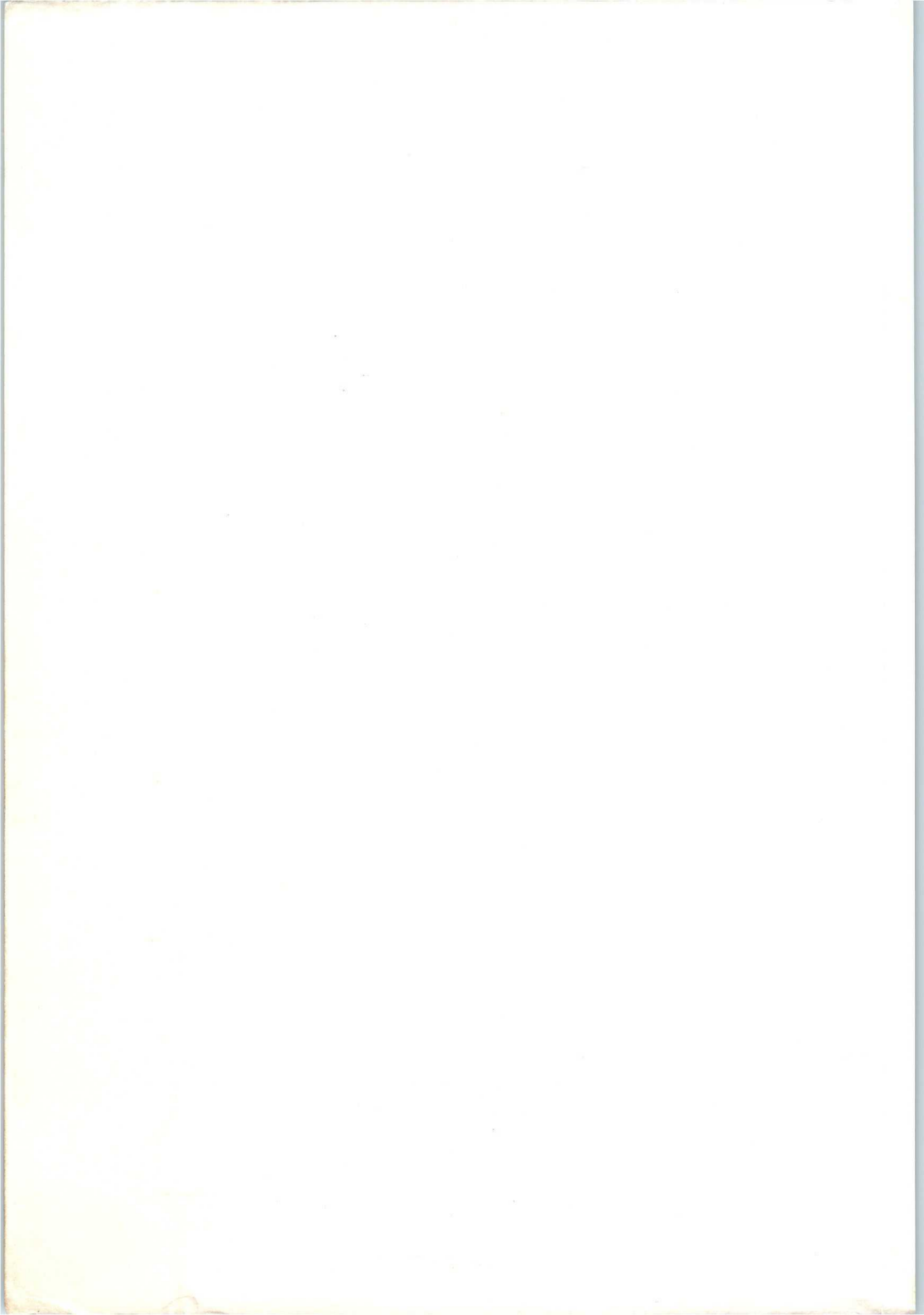

Publ D14-125?
ELECTRON TUBES

Part 5a

August 1976

CATHODE-RAY TUBES

General and screen types

Instrument tubes

Monitor and display tubes

C-R tubes for special applications

Associated accessories

Index, Maintenance type list, Obsolescent type list

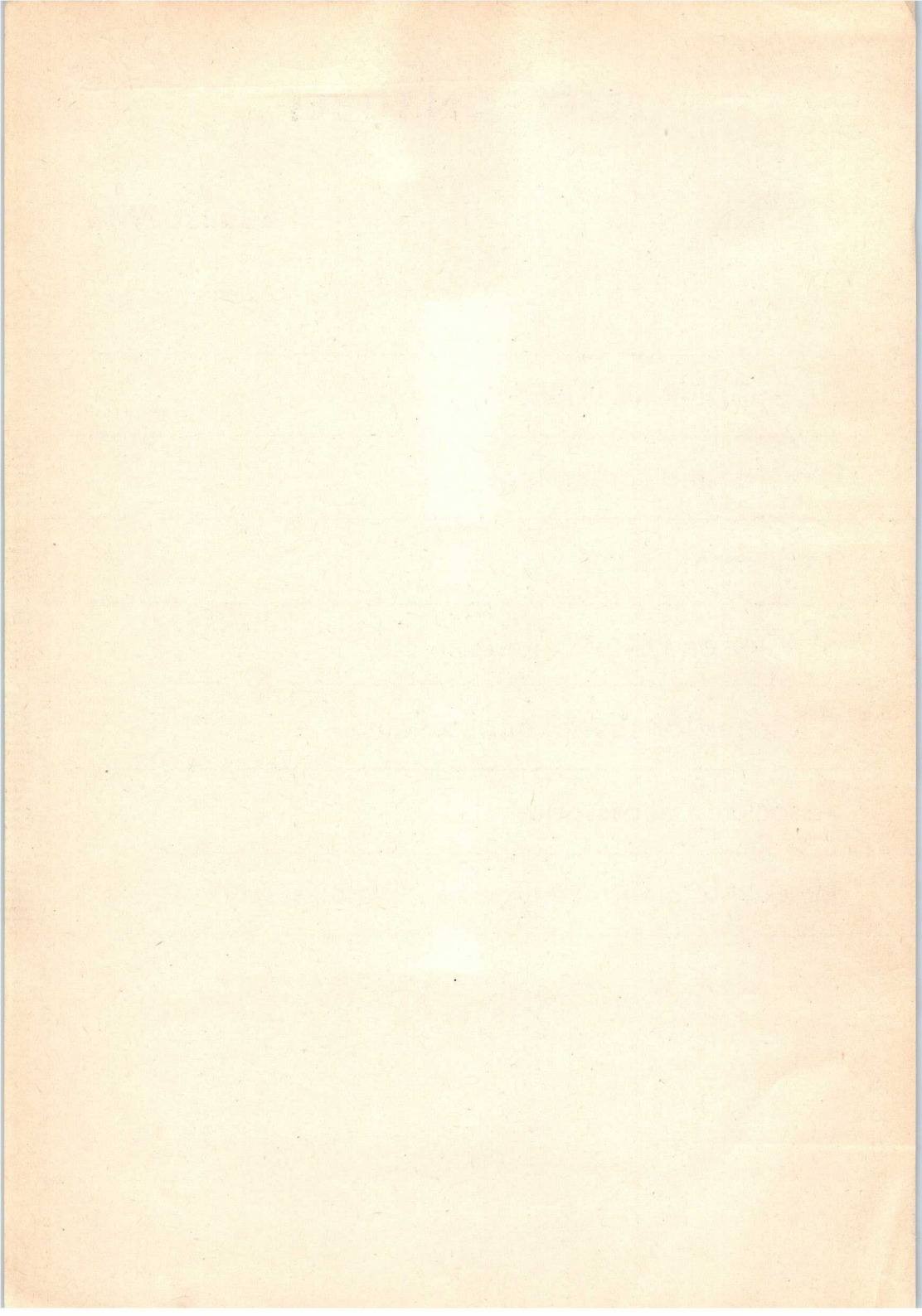

DATA HANDBOOK SYSTEM

Our Data Handbook System is a comprehensive source of information on electronic components, subassemblies and materials; it is made up of three series of handbooks each comprising several parts.

ELECTRON TUBES

BLUE

SEMICONDUCTORS AND INTEGRATED CIRCUITS

RED

COMPONENTS AND MATERIALS

GREEN

The several parts contain all pertinent data available at the time of publication, and each is revised and reissued periodically.

Where ratings or specifications differ from those published in the preceding edition they are pointed out by arrows. Where application information is given it is advisory and does not form part of the product specification.

If you need confirmation that the published data about any of our products are the latest available, please contact our representative. He is at your service and will be glad to answer your inquiries.

This information is furnished for guidance, and with no guarantee as to its accuracy or completeness; its publication conveys no licence under any patent or other right; nor does the publisher assume liability for any consequence of its use; specifications and availability of goods mentioned in it are subject to change without notice: it is not to be reproduced in any way, in whole or in part without the written consent of the publisher.

ELECTRON TUBES (BLUE SERIES)

This series consists of the following parts, issued on the dates indicated.

Part 1a	Transmitting tubes for communication and Tubes for r.f. heating Types PE05/25 - TBW15/125	December 1975
Part 1b	Transmitting tubes for communication Tubes for r.f. heating Amplifier circuit assemblies	January 1976
Part 2	Microwave products Communication magnetrons Magnetrons for microwave heating Klystrons Travelling-wave tubes	May 1976
	Diodes Triodes T-R Switches Microwave semiconductor devices Isolators - circulators	
Part 3	Special Quality tubes; Miscellaneous devices	January 1975
Part 4	Receiving tubes	March 1975
Part 5a	Cathode-ray tubes	August 1975
Part 5b	Camera tubes; Image intensifier tubes	May 1975
Part 6	Products for nuclear technology Channel electron multipliers Geiger-Mueller tubes Neutron tubes	July 1975
Part 7	Gas-filled tubes Voltage stabilizing and reference tubes Counter, selector, and indicator tubes Trigger tubes Switching diodes	August 1975
	Thyratrons Ignitrons Industrial rectifying tubes High-voltage rectifying tubes	
Part 8	TV Picture tubes	October 1975
Part 9	Photomultiplier tubes Phototubes (diodes)	June 1976

SEMICONDUCTORS AND INTEGRATED CIRCUITS (RED SERIES)

This series consists of the following parts, issued on the dates indicated.

Part 1a	Rectifier diodes, thyristors, triacs		March 1976
	Rectifier diodes	Rectifier stacks	
	Voltage regulator diodes (> 1,5 W)	Thyristors	
	Transient suppressor diodes	Triacs	
Part 1b	Diodes		October 1975
	Small signal germanium diodes	Voltage regulator diodes (< 1,5 W)	
	Small signal silicon diodes	Voltage reference diodes	
	Special diodes	Tuner diodes	
Part 2	Low-frequency transistors		December 1975
Part 3	High-frequency and switching transistors		April 1976
Part 4a	Special semiconductors		June 1976
	Transmitting transistors	Dual transistors	
	Microwave devices	Microminiature devices for	
	Field-effect transistors	thick- and thin-film circuits	
Part 4b	Devices for optoelectronics		July 1976
	Photosensitive diodes and transistors	Photocouplers	
	Light emitting diodes	Infrared sensitive devices	
	Displays	Photoconductive devices	
Part 5	Linear integrated circuits		March 1975
Part 6	Digital integrated circuits		May 1976
	LOC MOS HE family		
	GZ family		

COMPONENTS AND MATERIALS (GREEN SERIES)

This series consists of the following parts, issued on the dates indicated.

Part 1	Functional units, Input/output devices, Peripheral devices		November 1975
	High noise immunity logic FZ/30-Series	Circuit blocks 90-Series	
	Circuit blocks 40-Series and CSA70	Input/output devices	
	Counter modules 50-Series	Hybrid integrated circuits	
	NORbits 60-Series, 61-Series	Peripheral devices	
Part 2a	Resistors		February 1976
	Fixed resistors	Negative temperature coefficient thermistors (NTC)	
	Variable resistors	Positive temperature coefficient thermistors (PTC)	
	Voltage dependent resistors (VDR)	Test switches	
	Light dependent resistors (LDR)		
Part 2b	Capacitors		April 1976
	Electrolytic and solid capacitors	Ceramic capacitors	
	Paper capacitors and film capacitors	Variable capacitors	
Part 3	Radio, Audio, Television		February 1975
	FM tuners	Components for black and white television	
	Loudspeakers	Components for colour television	
	Television tuners and aerial input assemblies		
Part 4a	Soft ferrites		April 1975
	Ferrites for radio, audio and television	Ferroxcube potcores and square cores	
	Beads and chokes	Ferroxcube transformer cores	
Part 4b	Piezoelectric ceramics, Permanent magnet materials		May 1975
Part 5	Ferrite core memory products		July 1975
	Ferroxcube memory cores	Core memory systems	
	Matrix planes and stacks		
Part 6	Electric motors and accessories		September 1975
	Small synchronous motors	Miniature direct current motors	
	Stepper motors		
Part 7	Circuit blocks		September 1971
	Circuit blocks 100 kHz-Series	Circuit blocks for ferrite core memory drive	
	Circuit blocks 1-Series		
	Circuit blocks 10-Series		
Part 8	Variable mains transformers		July 1975
Part 9	Piezoelectric quartz devices		March 1976
Part 10	Connectors		November 1975

General and screen types



Some devices are labelled

Maintenance type

Obsolescent type

or

Obsolete type

Maintenance type - Available for equipment maintenance
No longer recommended for equipment production.

Obsolescent type - Available until present stocks are exhausted.

Obsolete type - No longer available.

LIST OF SYMBOLS

Symbols denoting electrodes and electrode connections

Heater or filament	f
Cathode	k
Grid	g
Grids are distinguished by means of an additional numeral; the electrode nearest to the cathode having the lowest number.	
Deflection plates intended for deflection in horizontal direction.	x ₁ , x ₂
Deflection plates intended for deflection in vertical direction.	y ₁ , y ₂
Sectioned deflection plates are indicated by an additional decimal e.g. y _{1.1} y _{1.2} and y _{2.1} y _{2.2}	
External conductive coating	m
Fluorescent screen	ℓ
Tube pin which must not be connected externally	i.c.
Tube pin which may be connected externally	n.c.

Symbols denoting voltages

Symbol for voltage, followed by an index denoting the relevant electrode.	V
Heater or filament voltage	V _f
Peak value of a voltage	V _p
Peak to peak value of a voltage	V _{pp}

Symbols denoting currents

Remark I The positive electrical current is directed opposite to the direction of the electron current.

Remark II The symbols quoted represent the average values of the concerning currents unless otherwise stated.

Symbol for current followed by an index denoting the relevant electrode. I

Heater or filament current I_f

Symbols denoting powers

Dissipation of the fluorescent screen W_l

Grid dissipation W_g

Symbols denoting capacitances

See IEC Publication 100.

Symbols denoting resistances

Symbol for resistance followed by an index for the relevant electrode pair. When only one index is given the second electrode is the cathode. R

When R is replaced by Z the "resistance" should read "impedance".

Symbols denoting various quantities

Luminance B

Frequency f

Magnetic field strength H

Deflection coefficient M

GENERAL OPERATIONAL RECOMMENDATIONS CATHODE-RAY TUBES

GENERAL

Unless otherwise stated the data are given for a nominal tube.

LIMITING VALUES

Unless otherwise stated the tubes are rated according to the absolute maximum rating system.

HEATER

Parallel operation

The heater voltage must be within $\pm 7\%$ of the nominal value when the supply voltage is at its nominal value, and when a tube having the published heater characteristics is employed.

This figure is permissible only if the voltage variation is dependent upon more than one factor. In these circumstances the total tolerance may be taken as the square root of the sum of the squares of the individual deviations arising from the effect of the tolerances of the separate factors, providing no one of these deviations exceeds $\pm 5\%$. Should the voltage variation depend on one factor only, the voltage variation must not exceed $\pm 5\%$.

Series operation

The heater current must be within $\pm 5\%$ of the nominal value when the supply voltage is at its nominal value and a tube having the published heater characteristics is employed. This figure is permissible only if the current variation is dependent upon more than one factor. In these circumstances the total tolerance may be taken as the square root of the sum of the squares of the individual deviations arising from the effects of the tolerances of the separate factors, providing no one of these deviations exceeds $\pm 3.5\%$. Should the total current variation depend upon one factor only, the current variation must not exceed $\pm 3.5\%$.

When calculating the tolerances of associated components, the ratio of the change of heater voltage to the change of heater current in a typical series chain including a cathode ray tube is taken as 1.8, both deviations being expressed as percentages.

HEATER (continued)

With certain combinations of valves and tube, differences in the thermal inertia may result in particular heaters being run at exceedingly high temperature during the warming up period. During this period unless otherwise stated in the published data, it is permissible for the heater voltage of the tube to rise to a maximum value of 50 % in excess of the nominal rated value when using a tube with the published heater characteristics. A surge limiting device may be necessary in order to meet this requirement. When measuring the surge value of heater voltage, it is important to employ a peak reading device, such as an oscilloscope.

In addition to the quoted above, fluctuations in the mains supply voltage not exceeding $\pm 10\%$ are permissible. These conditions are, however, the worst which are acceptable and it is better practise to maintain the heater as close to its published ratings as possible. Furthermore in all types of equipment closer adjustment of heater voltage or current will react favourably upon tube life and performance.

CATHODE

The potential difference between cathode and heater should be as low as possible and in any case must not exceed the limiting value given on the data sheets for individual tubes. Operation with the heater positive with respect to cathode is not recommended. In order to avoid excessive hum the A.C. component of the heater-to-cathode voltage should be as low as possible e.g. less than $20 V_{\text{rms}}$. When the heater is in a series chain or earthed, the 50 c/s impedance between heater and cathode should not exceed $100 \text{ k}\Omega$. If the heater is supplied from separate transformer windings the resistance between heater and cathode must not exceed $1 \text{ M}\Omega$.

ELECTRODES

In no circumstances should the tube be operated without a D.C. connection between each electrode and the cathode. The total effective impedance between any electrode and the cathode should be as low as possible and must never be allowed to exceed the published maximum value.

ELECTRODE VOLTAGES

Reference point for electrode voltages is the cathode. For cathode drive service the reference point is grid No.1.

Grid cut-off voltages

Values are given for the limits of grid cut-off voltage per unit of the first accelerator voltage. The brightness control voltage should be arranged so that it can handle any tube within the limits shown, at the appropriate first accelerator voltage.

First accelerator voltage

The first accelerator electrode of a so called unipotential lens provides by applying a fixed voltage independent focus and brightness controls. Care should be taken not to exceed the maximum and minimum limits for reasons of reliability and performance.

Deflection blanking electrode voltage

The mean potential of the deflection blanking electrode should be equal to that of the first accelerator.

If applicable the voltage difference (ΔV_{g3}) given in the data should be applied to the beam blanking electrode to obtain beam blanking of a stated beam current for all tubes of the relevant type.

Focusing voltage

The focusing electrode voltage limits are given in the data. The focus voltage supply should be arranged such that it can handle these limits, so that in any tube the cross-sectional area of the electron-beam on the screen can be optimally displayed. As the focus current is very limited a high resistance series chain may be used.

Astigmatism control electrode voltage

To achieve optimum performance under all conditions it is desirable to apply a voltage for control of astigmatism (a difference in potential of this electrode and the y plates). The required range to cover any tube is given in the relevant data.

Beam centring electrode voltage

The beam centring electrode facilitates the possibility to centre the scan in x-direction with respect to the geometric centre of the faceplate by applying a voltage, the limits of which are given in the relevant data, to this electrode. Optimum condition is obtained when the brightness at both left and right edges of the scan are equal.

Deflection plate shield voltage

It is essential that the deflection plate shield voltage equals the mean y plates voltage.

Geometry control electrode voltage

By varying the potential of this electrode the necessary range of which is given in the relevant data the possible occurrence of pin-cushion and barrel-pattern distortion can be controlled.

Deflection voltages

For optimum performance it is essential that true symmetrical voltages are applied. It should further be noted that the mean x and y plate potentials must be equal. Moreover the deflection plate shield voltage, the mean astigmatism control voltage, if applicable the mean beam centring electrode voltage and the geometry electrode voltage should also be equal to the mean x and y plate potentials. If use is made of the full deflection capabilities of the tube, the deflection plates will intercept part of the electron beam near the edge of the scan. Therefore a low impedance deflection plate drive is necessary.

Raster distortion and its determination

Limits of raster distortion are given for most tubes.

A graticule, consisting of concentric rectangles is aligned with the electrical x axis of the tube. The edges of a raster will fall between these rectangles with optimum correction potentials applied.

Measuring procedure:

- a) Shift the x-trace to the centre of the graticule.
- b) Align horizontal centre line of graticule with the centre line of the x-trace.
- c) Shift x-trace vertically between resp. upper and lower two horizontal lines of graticule.
The centre of the x-trace now will not fall outside the area bounded by the horizontal graticule lines.
- d) Without moving the graticule, switch to a vertical trace and shift this trace horizontally (resp. left and right) between the pairs of vertical lines of the graticule, and also now the centre of the y-trace will not fall outside the area bounded by the vertical graticule lines.
- e) Focus and astigmatism will be adjusted for optimum performance.
- f) Pattern geometry correction will be adjusted for optimum performance in the sense of minimizing simultaneously the deviation of the centre of x- respectively y-trace.

Linearity

The linearity is defined as the sensitivity at a deflection of 75 % of the useful scan with respect to differ from the sensitivity at a deflection of 25 % of the useful scan. These sensitivities will not differ by more than the indicated value.

Post deflection shield voltage

In order to optimize contrast in mesh tubes a fixed negative voltage with respect to the geometry control electrode voltage should be applied. The range is given in the data.

Helix resistance

In order to calculate the high tension supply a minimum resistance is given in the data.

Final accelerator voltage

Tubes with PDA are designed for a given final accelerator voltage to astigmatism control electrode voltage ratio. Operation at higher ratio may result in changes in deflection uniformity and pattern distortion.

High tension supply

In order to avoid damage of the screen it is important that prior to the high tension a deflection voltage e.g. the time base voltage is applied.

LINE WIDTH

Shrinking raster method. Conditions as given in the relevant data.

Focus and astigmatism potentials should be adjusted for optimum performance. Optimum performance is that adjustment which will simultaneously minimize the horizontal and vertical trace widths at the centre of the useful scan.

The raster shall be compressed until the line structure first disappears or begins to overlap or show reverse line structure.

The line width is equal to the quotient of the width of the compressed pattern transverse to the line structure divided by the number of lines which are being scanned.

In older types the line width is measured on a circle with the aid of a microscope.

CAPACITANCES

Unless otherwise stated the values given are nominal values measured on a cold tube on the tube contacts. The contacts and measuring leads or sockets being screened.

MOUNTING

Unless otherwise stated the mounting position is any. However, the tube should not be supported by the base alone and under no circumstances should the socket be allowed to support the tube.

To avoid dangerous glass strain care should be taken when installing the tube.

Shielding

The tubes must be shielded against electrical and magnetic fields.

Special attention should be paid to the mounting of transformers, coils etc.

SCREEN

To prevent screen burn stationary or slow moving spots together with high screen currents should be avoided.

If measurements are to be made under high ambient light conditions it is advisable to use a contrast improving filter and or a light hood.

TRACKING ERROR

Tracking is the ability of a multigun tube to superimpose simultaneously information from each gun.

Tracking error is the maximum allowable distance between the displays of any two guns.

PHOTOMETRIC UNITS

1. S.I. photometric units

quantity	S.I. units	remarks
luminous intensity	cd (candela)	
luminous flux	lm (lumen)	
quantity of light	lm · s	
luminance	cd/cm ²	1 cd/m ² = 1 nit
luminous exitance	lm/m ²	formerly luminous emittance
illuminance	lx (lux)	formerly illumination

2. Other photometric units; conversion factors

stilb = 1 candela/cm² = 4π lumen/cm²

lambert = $\frac{1}{\pi}$ candela/cm² = 4 lumen/cm²

apostilb = $\frac{1}{\pi}$ candela/m²

foot lambert = $\frac{1}{\pi}$ candela/ft²

Luminance unit conversion factors

1	stilb	cd/ft ²	lambert	foot lambert	apostilb	
equals	10 ⁴	10, 76	3, 183 x 10 ³	3, 426	0, 3183	cd/m ² (nit)

Illuminance conversion factors

1	phot (lm/cm ²)	foot-candle (lm/ft ²)	
equals	10 ⁴	1, 076 x 10 ⁻³	lux (lm/m ²)

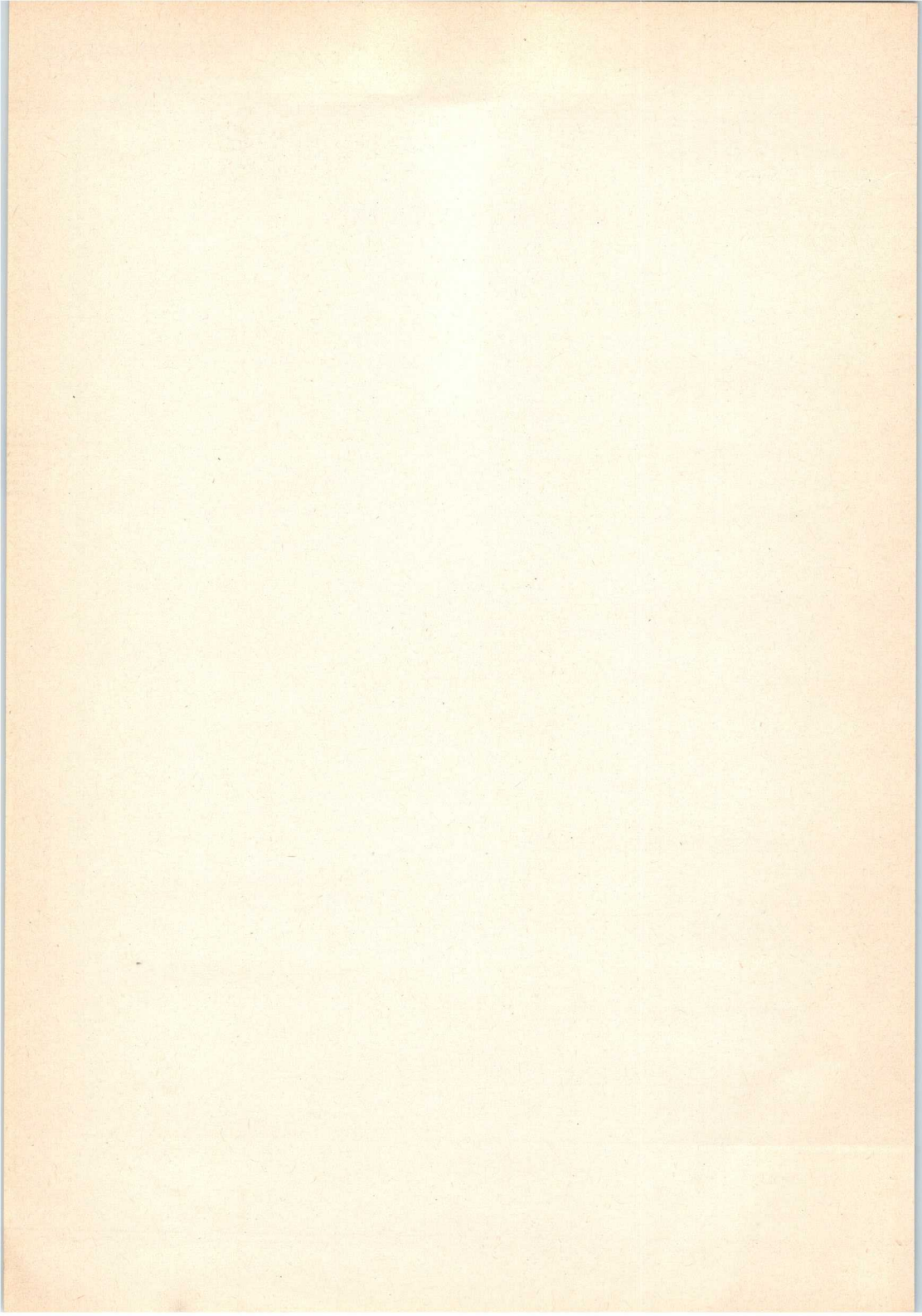

RATING SYSTEMS

(in accordance with I.E.C. publication 134)

Absolute maximum rating system

Absolute maximum ratings are limiting values of operating and environmental conditions applicable to any electronic device of a specified type as defined by its published data, which should not be exceeded under the worst probable conditions.

These values are chosen by the device manufacturer to provide acceptable serviceability of the device, taking no responsibility for equipment variations, environmental variations, and the effects of changes in operating conditions due to variations in the characteristics of the device under consideration and of all other electronic devices in the equipment.

The equipment manufacturer should design so that, initially and throughout life, no absolute-maximum value for the intended service is exceeded with any device under the worst probable operating conditions with respect to supply voltage variation, equipment component variation, equipment control adjustment, load variations, signal variation, environmental conditions, and variations in characteristics of the device under consideration and of all other electronic devices in the equipment.

Design-maximum rating system

Design-maximum ratings are limiting values of operating and environmental conditions applicable to a bogey electronic device of a specified type as defined by its published data, and should not be exceeded under the worst probable conditions.

These values are chosen by the device manufacturer to provide acceptable serviceability of the device, taking responsibility for the effects of changes in operating conditions due to variations in the characteristics of the electronic device under consideration.

The equipment manufacturer should design so that, initially and throughout life, no design-maximum value for the intended service is exceeded with a bogey device under the worst probable operating conditions with respect to supply-voltage variation, equipment component variation, variation in characteristics of all other devices in the equipment, equipment control adjustment, load variation, signal variation and environmental conditions.

Design-centre rating system

Design-centre ratings are limiting values of operating and environmental conditions applicable to a bogey electronic device of a specified type as defined by its published data, and should not be exceeded under normal conditions.

These values are chosen by the device manufacturer to provide acceptable serviceability of the device in average applications, taking responsibility for normal changes in operating conditions due to rated supply-voltage variation, equipment component variation, equipment control adjustment, load variation, signal variation, environmental conditions, and variations in the characteristics of all electronic devices.

The equipment manufacturer should design so that, initially, no design-centre value for the intended service is exceeded with a bogey electronic device in equipment operating at the stated normal supply-voltage.

TYPE DESIGNATION

Two type designation systems are currently in use for our C.R. tubes. All future tubes will have numbers in the "new system", earlier tubes will retain numbers in the "old system".

NEW CODE SYSTEM (PRO-ELECTRON TYPE DESIGNATION CODE)

The type number consists of a single letter followed by two sets of figures, and ends with one or two letters.

The first letter indicates the prime application of the tube:

- A - Television display tube for domestic application
- D - Oscilloscope tube - single trace
- E - Oscilloscope tube - multiple trace
- F - Radar display tube - direct view
- L - Display storage tube
- M - T.V. display tube for professional application - direct view
- P - Display tube for professional application - projection
- Q - Flying spot scanner

The first group of figures indicates the diameter or diagonal of the luminescent screen in cm.

The second group of figures is a two-figure or three-figure serial number indicating a particular design or development.

The second group of letters indicates the properties of the phosphor screen. The first letter denotes the colour of the fluorescence or phosphorescence in the case of long or very long afterglow screens.

The second letter of this group is a serial letter to denote other specific differences in screen properties.

For the standard television tube phosphors, the letters 'W' and 'X' are used without a second letter.

TYPE DESIGNATION

- A - Purple - reddish purple - bluish purple
- B - Blue - purplish blue - greenish blue
- D - Blue green
- G - Green - bluish green - yellowish green
- K - Yellow - green
- L - Orange - Orange pink
- R - Red - reddish orange - red purple - purplish red - pink - purplish pink
- Y - Yellow - greenish yellow - yellowish orange
- W - White screen for T.V. display tubes
- X - Three-colour screen for T.V. display tubes

OLD SYSTEM

The type number consists of two letters followed by two sets of figures.
The first letter indicates the method of focusing and deflection:

- A - Electrostatic focusing and electromagnetic deflection
- D - Electrostatic focusing and electrostatic deflection
- M - Electromagnetic focusing and electromagnetic deflection

The second letter indicates the properties of the phosphor screen.

See also section "Screen Phosphors"

The first group of figures:

for round tubes: screen diameter in cm

for rectangular tubes: screen diagonal in cm

The second group of figures denotes the serial number.

SCREEN TYPES

new system	old system	fluorescent colour	phosphorescent colour	persistence	equivalent Jedec designation
BA	C	purplish-blue	-	very short	-
BE	B	blue	blue	medium short	P11
BF	U ¹⁾	purplish-blue	-	medium short	-
<u>GH</u>	H	<u>green</u>	<u>green</u>	<u>medium short</u>	P31
GJ	G	yellowish-green	yellowish-green	medium	P1
GK	G ¹⁾	yellowish-green	yellowish-green	medium	-
<u>GM</u>	P	<u>purplish-blue</u>	yellowish-green	<u>long</u>	P7
<u>GP</u>	-	<u>bluish-green</u>	green	<u>medium short</u>	P2
GR	-	green	green	long	P39
GU	-	white	white	very short	-
LA	D	orange	orange	medium	-
LB	E	orange	orange	long	-
LC	F	orange	orange	very long	-
LD	L	orange	orange	very long	P33
<u>W</u>	W	white	-	-	P4
WA	-	white	-	-	-
X	X	tri-colour screen	-	-	-
YA	Y ¹⁾	yellowish-orange	yellowish-orange	medium	-

¹⁾ Used in projection tubes.

SURVEY OF PERSISTENCE OF CATHODE-RAY TUBE SCREENS

Screen type		Application	Persistence				
New system	Old system		Relative level of luminance				
			10%	1%	0,1%		
BA GU	C -	Flying spot scanners	0,13 μ s 0,16 μ s	0,4 μ s 1,0 μ s	- -		
BE GH GJ GM GP	B H G P -		Oscilloscopes	20 ms 600 μ s 28 ms 60 ms 1,2 ms	70 ms 8 ms 75 ms 1,5 s 140 ms	120 ms 90 ms 120 ms 13 s 2 s	
GR	-	Monitors		100 ms	1,4 s	9 s	
W	W			yellow comp.	0,6 ms	7 ms	17 ms
				blue comp.	0,4 ms	4 ms	14,5 ms
WA	-			yellow comp.	3 ms	23 ms	104 ms
		blue comp.	3 ms	28 ms	148 ms		
LA LC LD	D F L	Radar	32 ms 0,3 s 0,5 s	110 ms 22 s 45 s	200 ms 50 s 100 s		

OPERATING CONDITIONS

Final accelerator voltage		Screen current
Oscilloscope types	4 kV	5 μ A/cm ²
Monitor types	10 to 18 kV	0,1 μ A/cm ²
Focusing	defocused	
Excitation	sufficient for complete build-up	

*meter's
0,6 μ A/cm²*

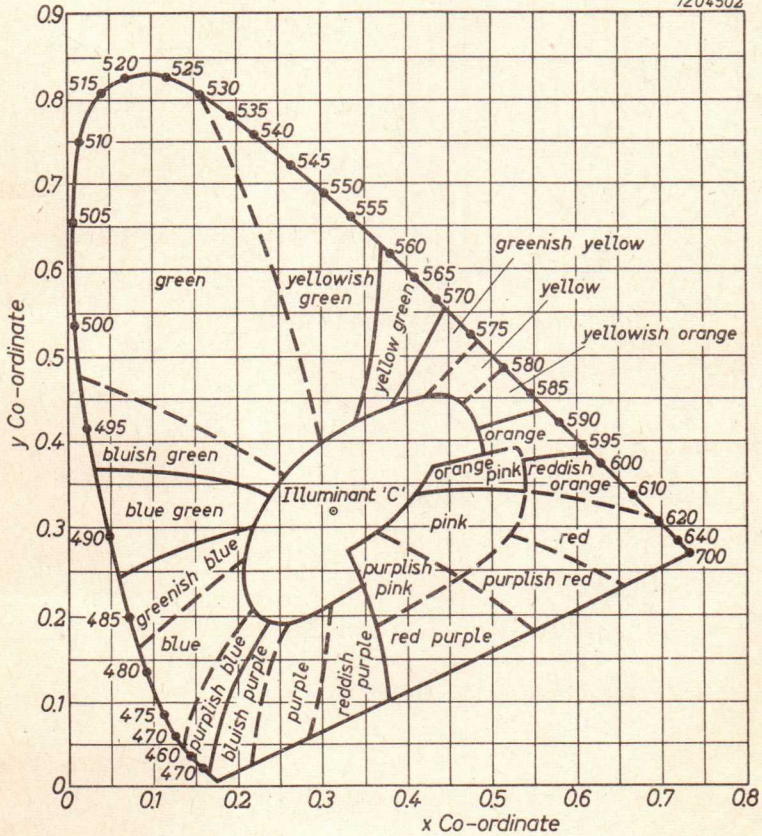

Kelly Chart

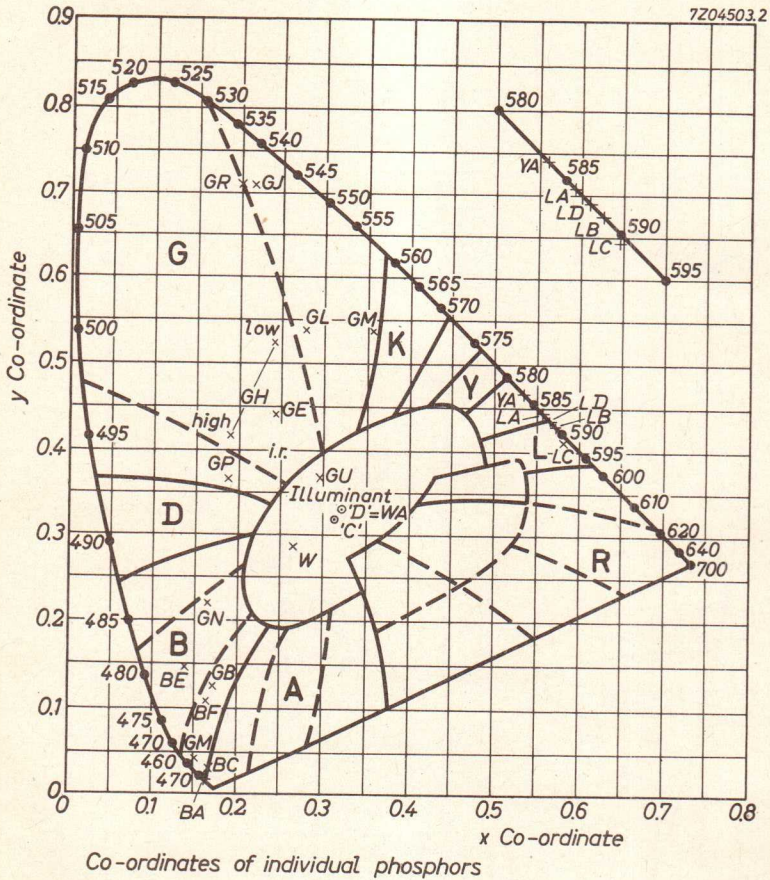

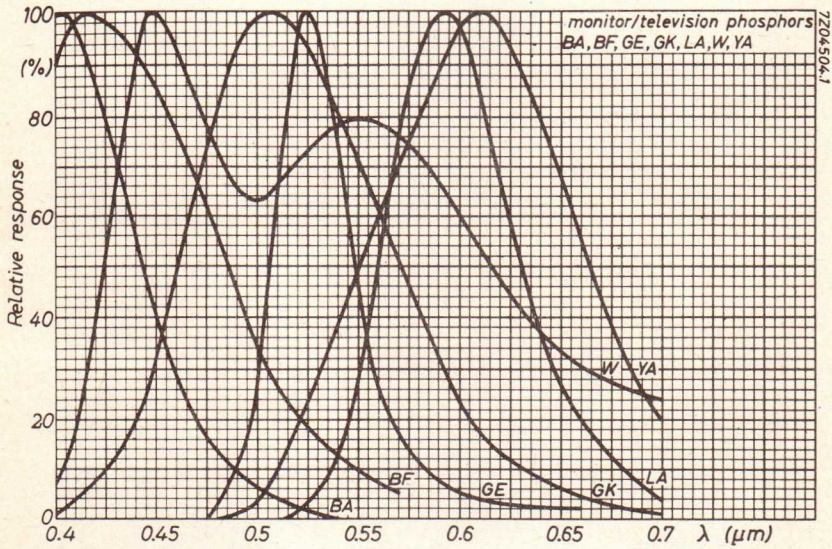

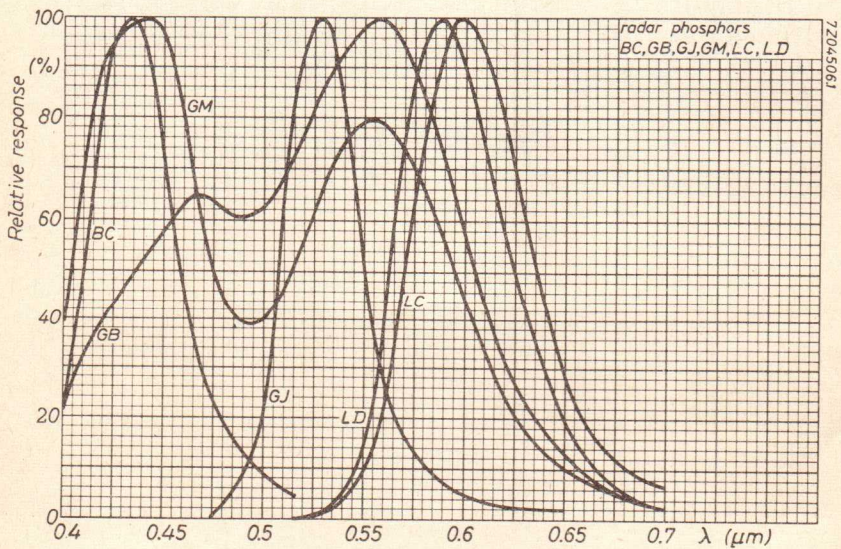
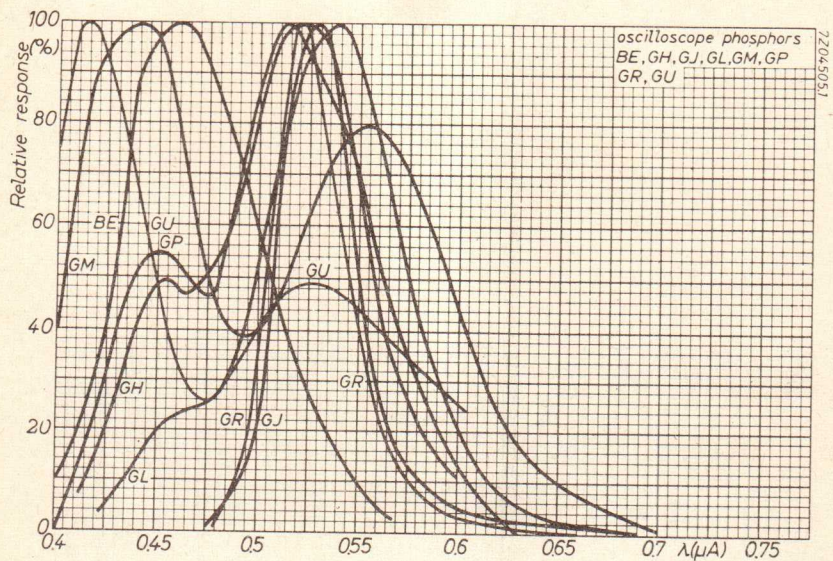

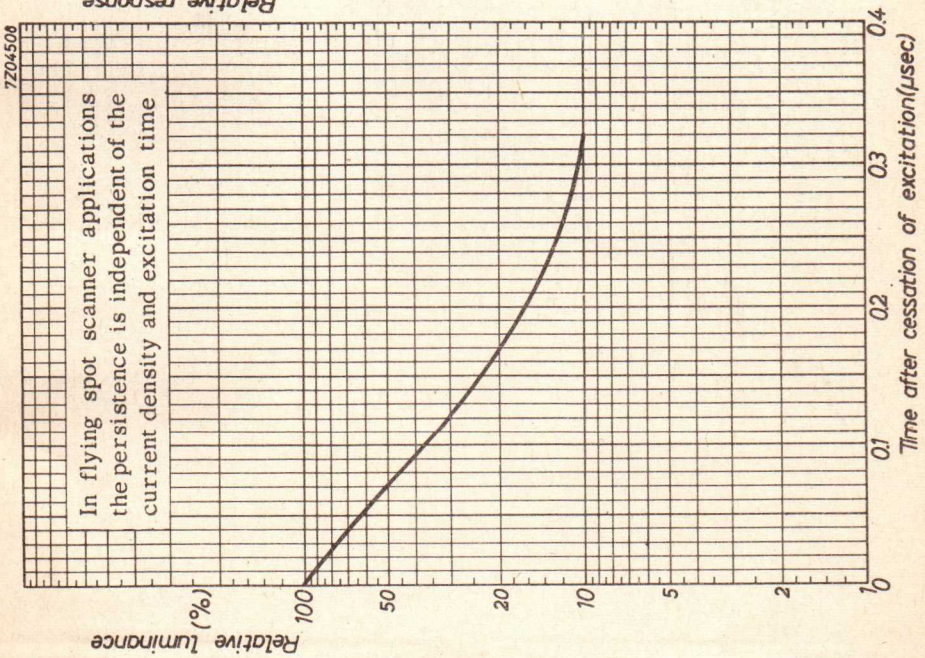
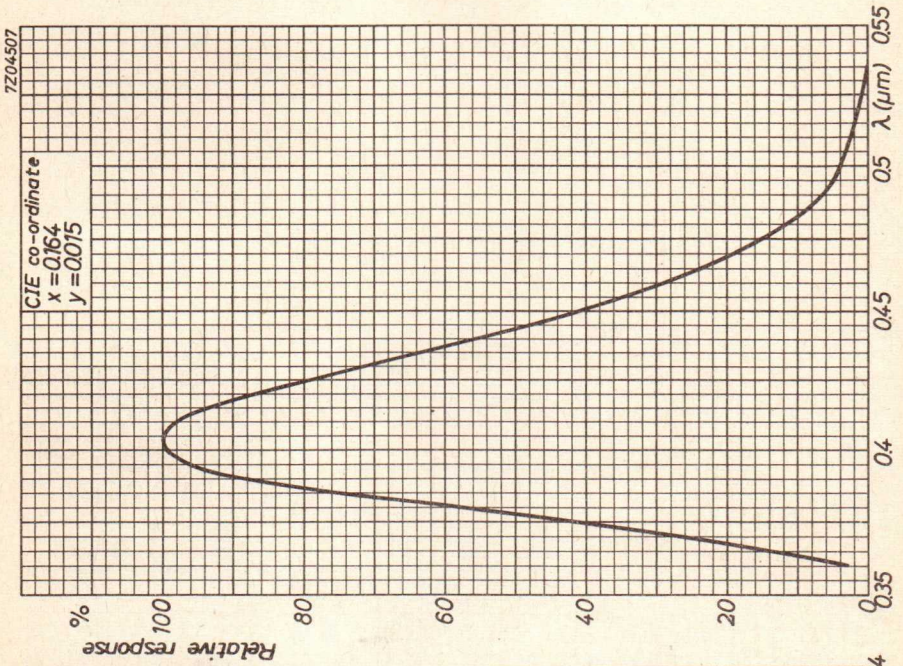

BA screen

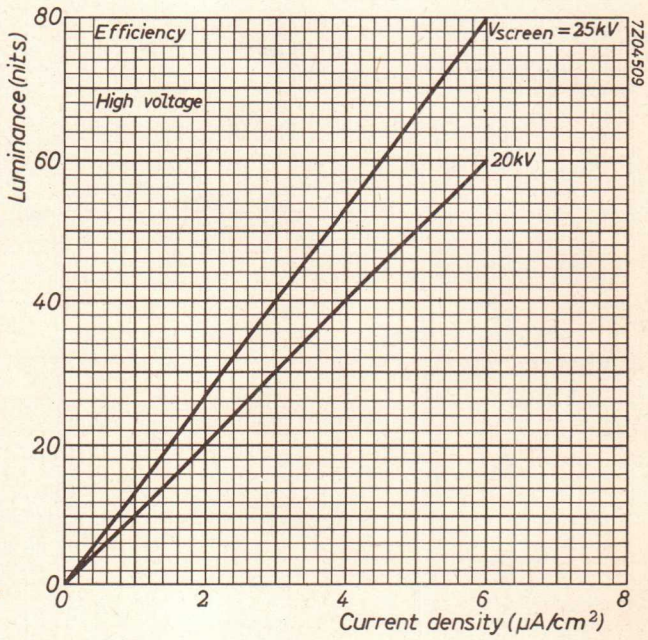
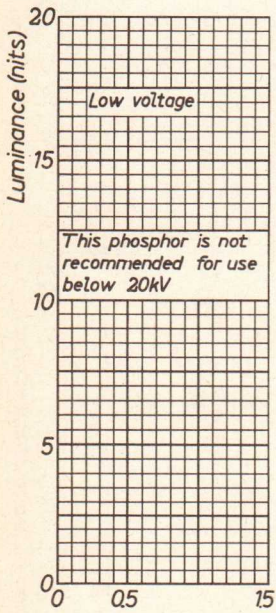

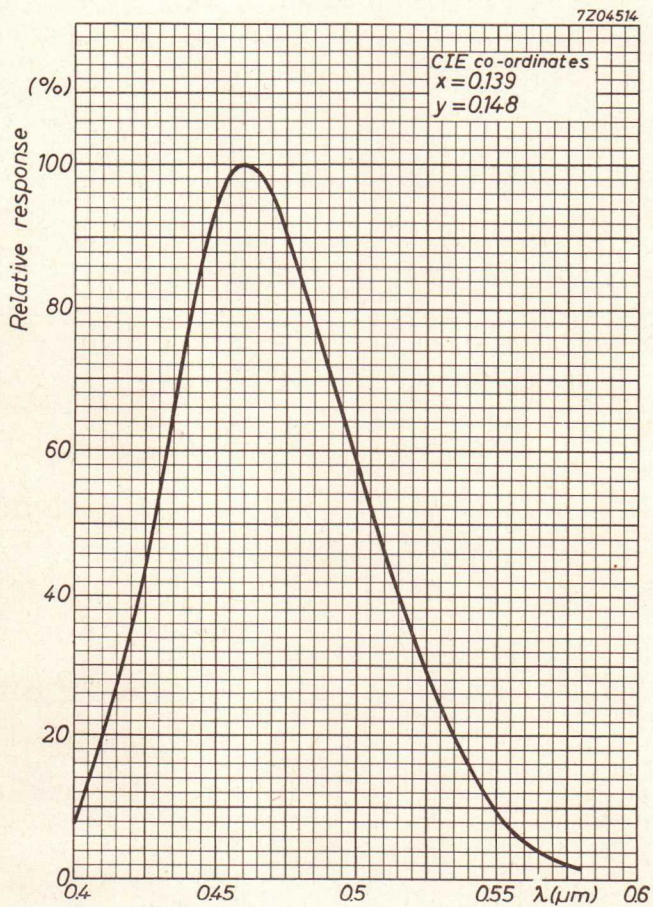

BE screen

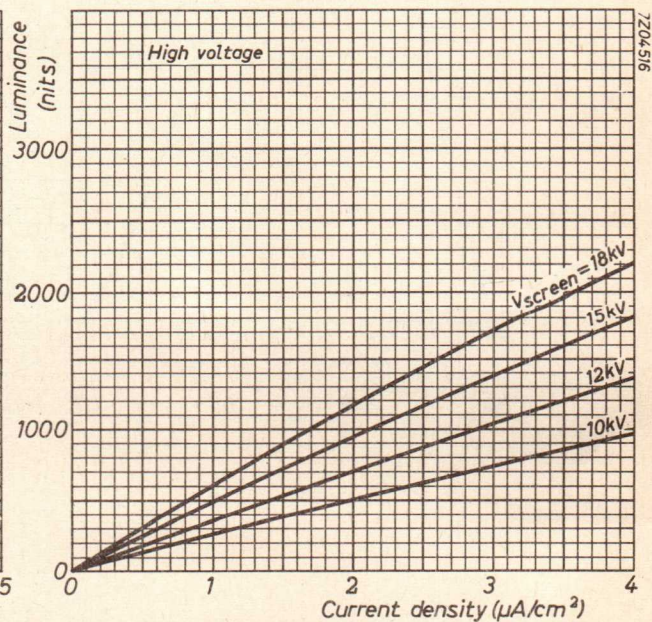
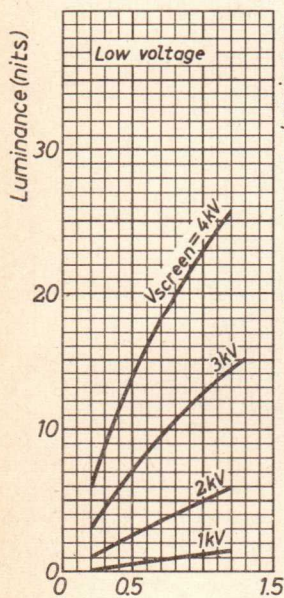
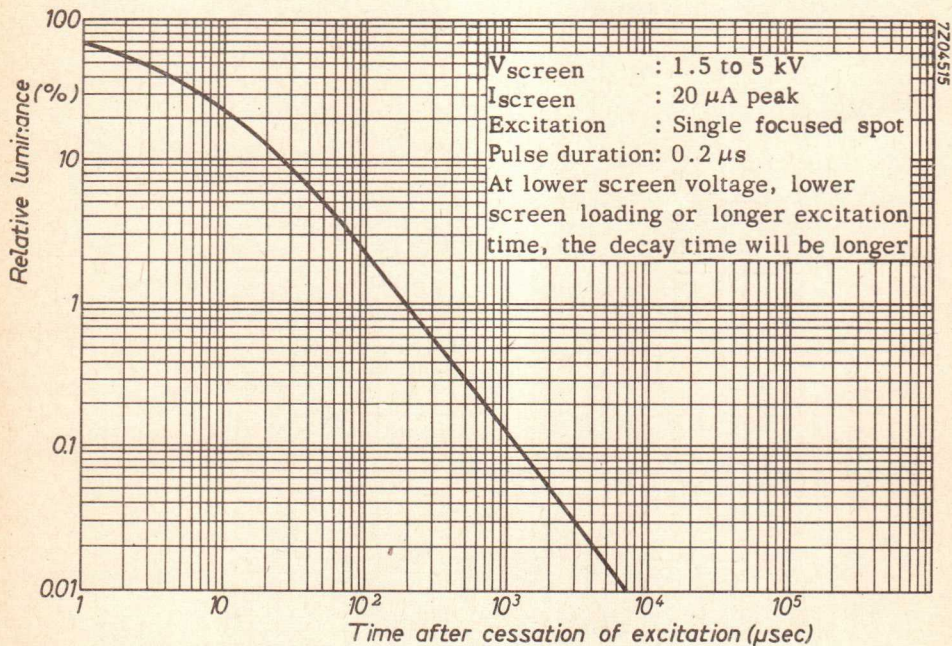

7204517

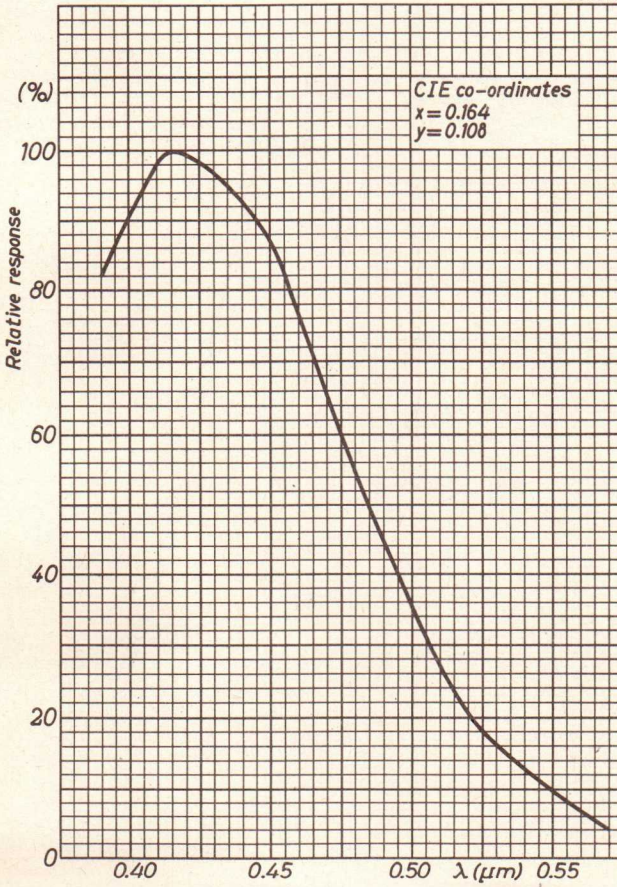

7204525

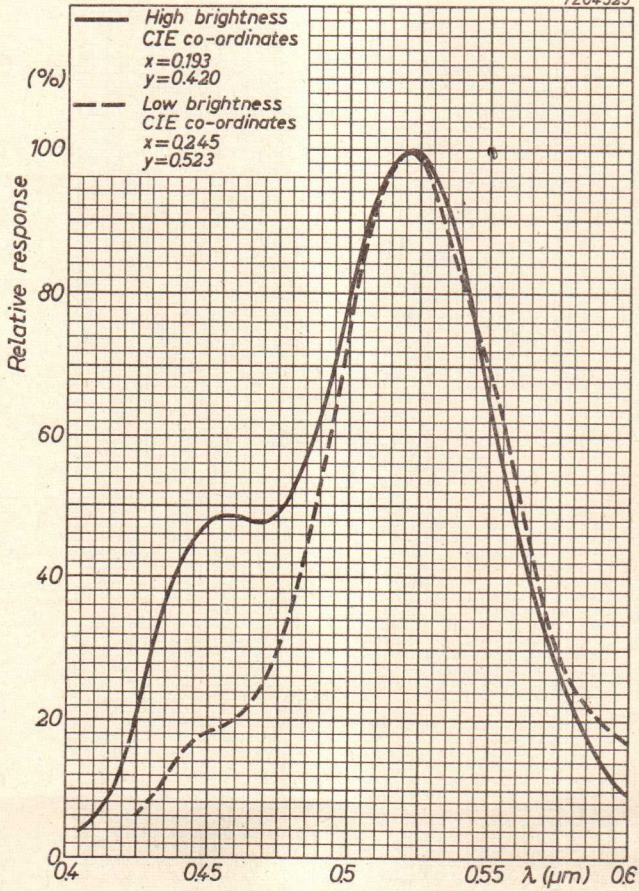

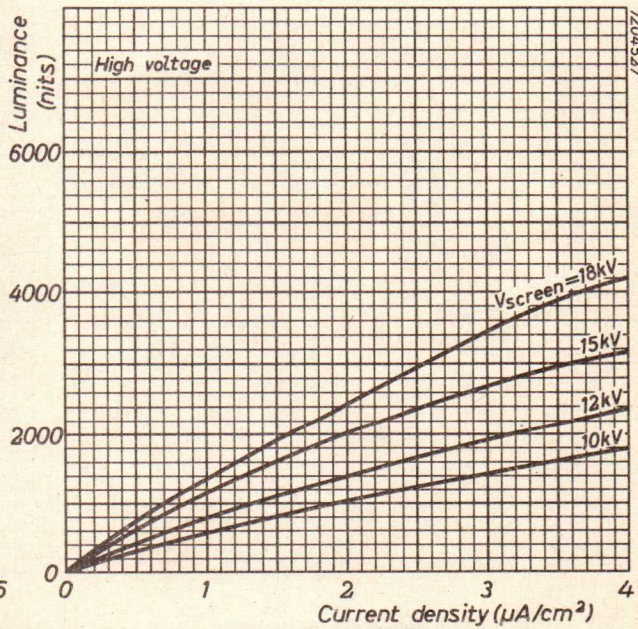
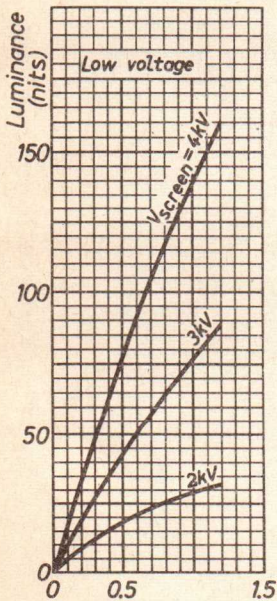
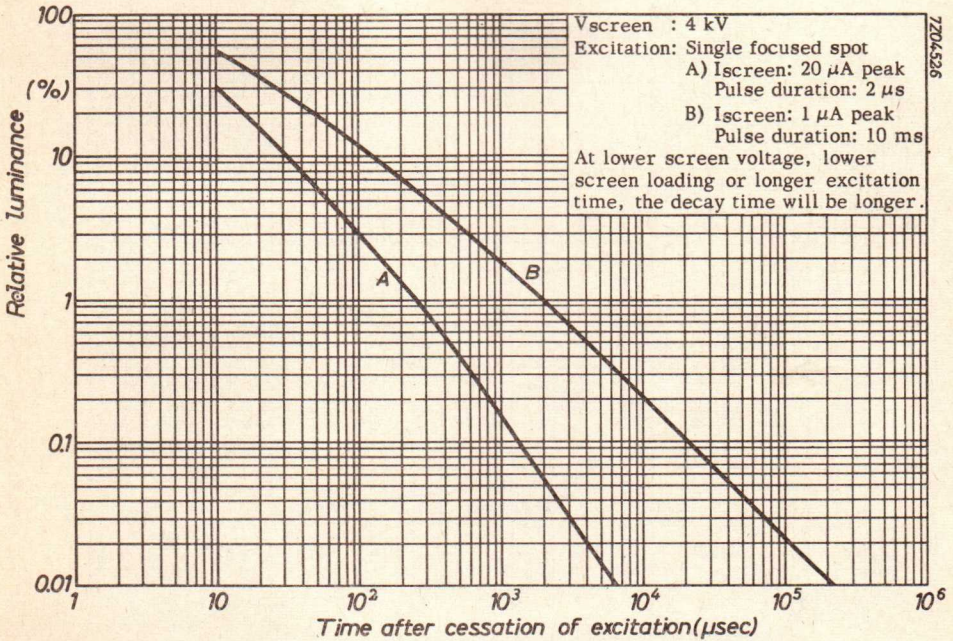

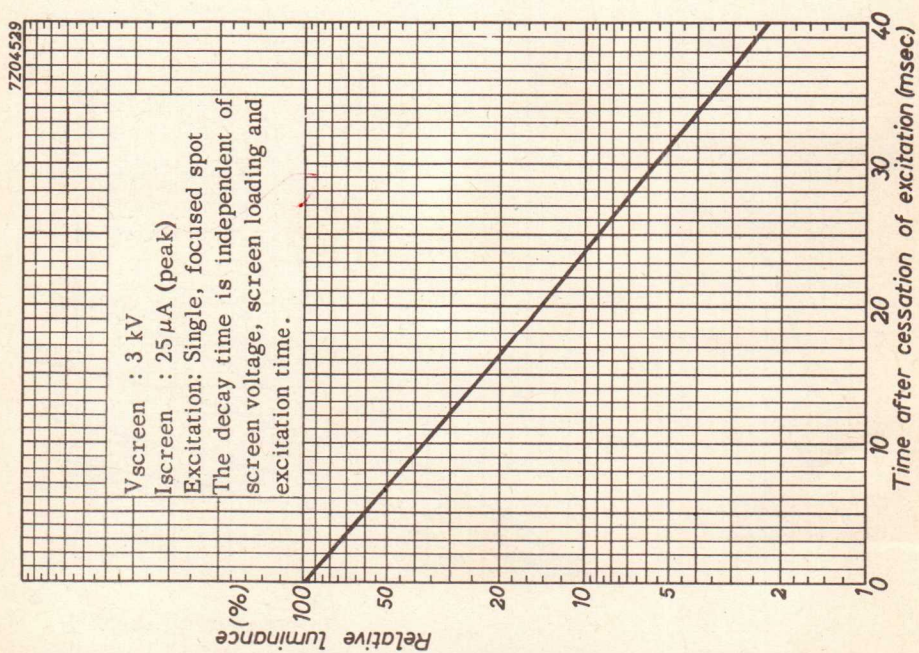
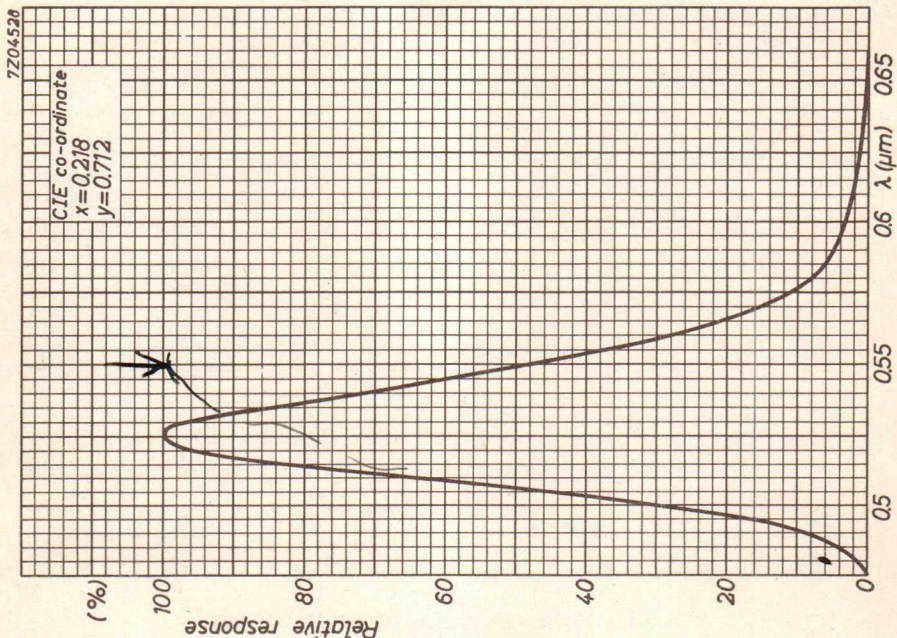

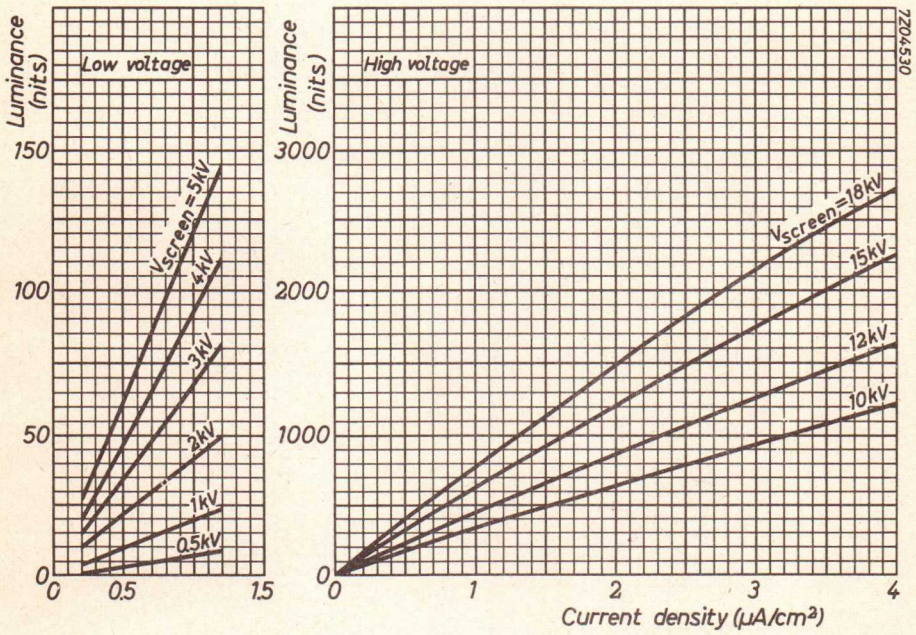

7204534

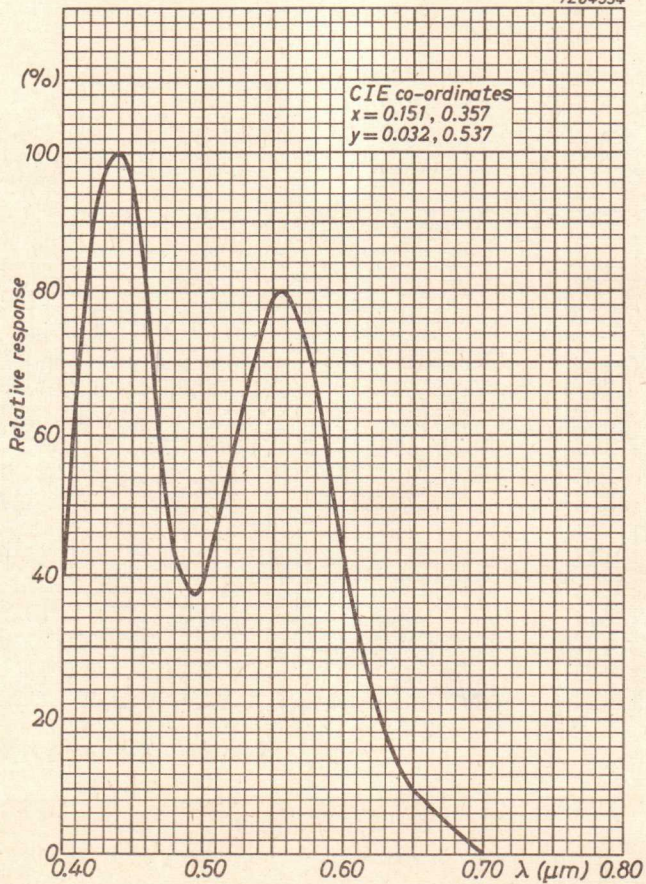

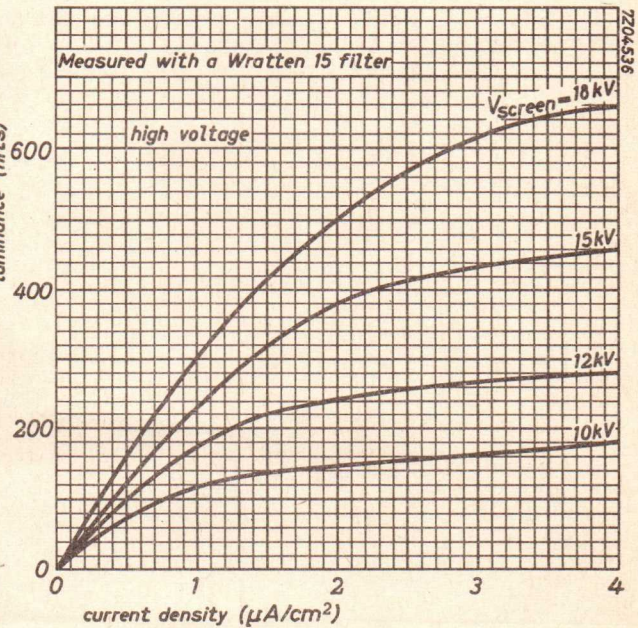
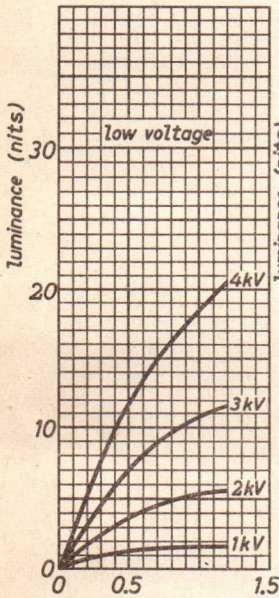
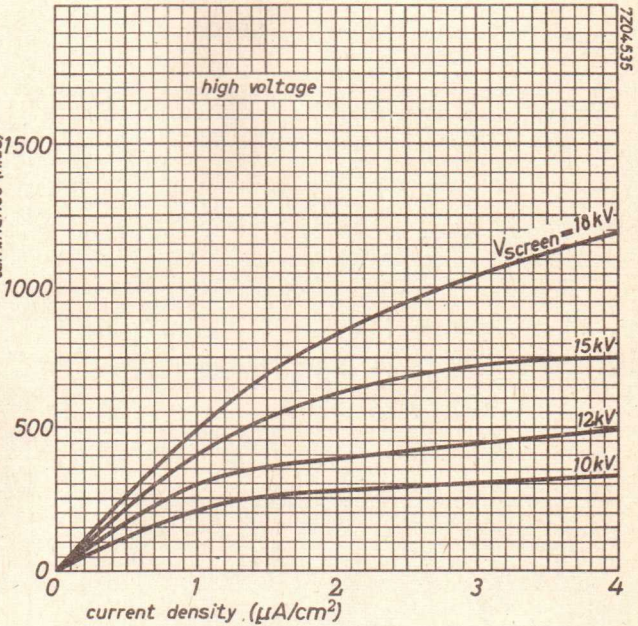
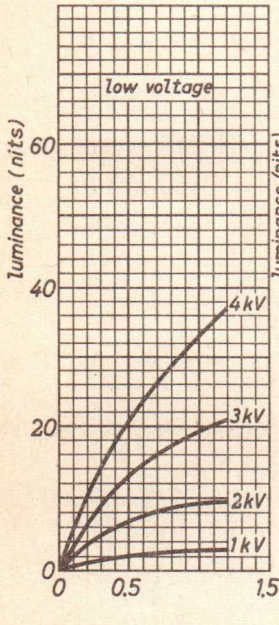

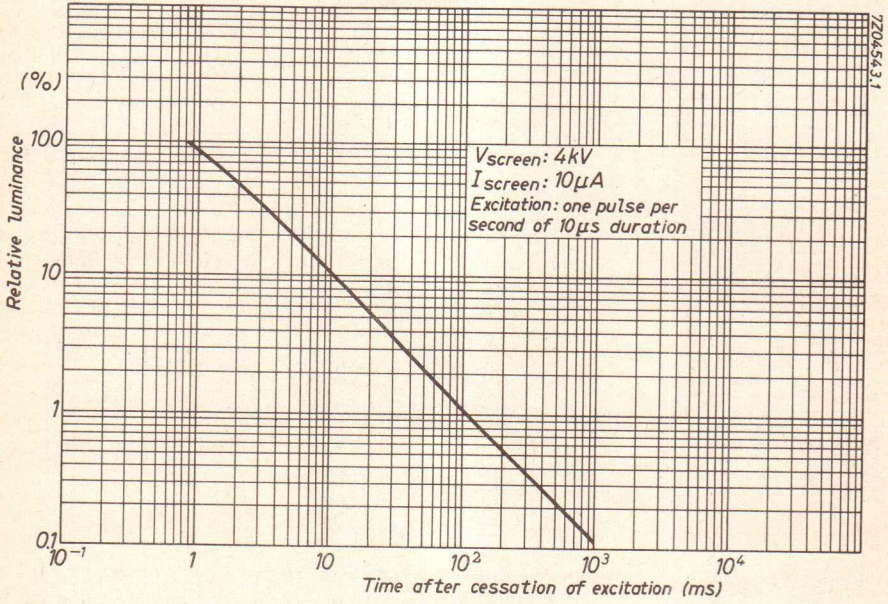

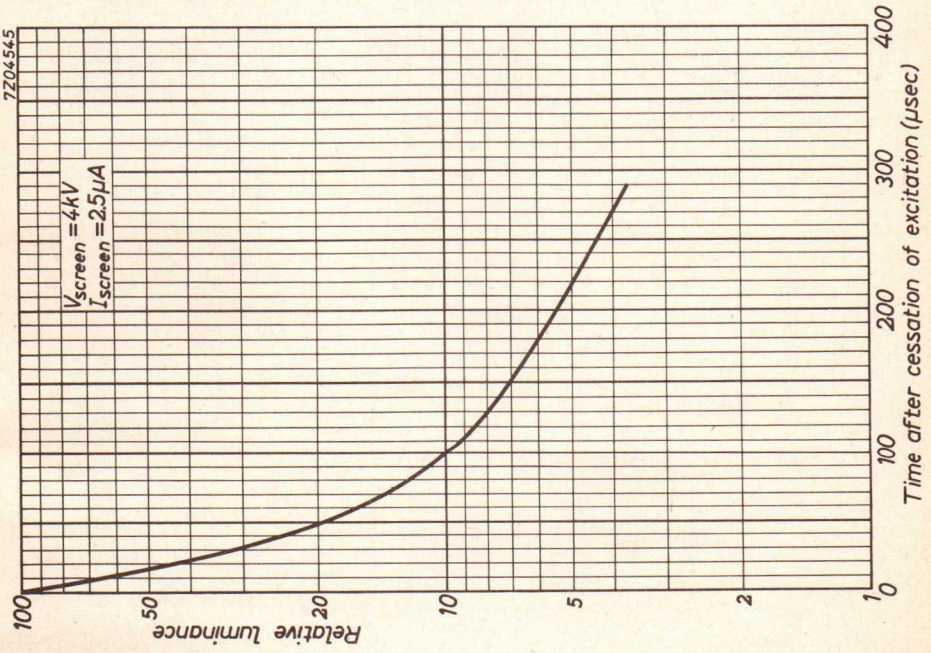
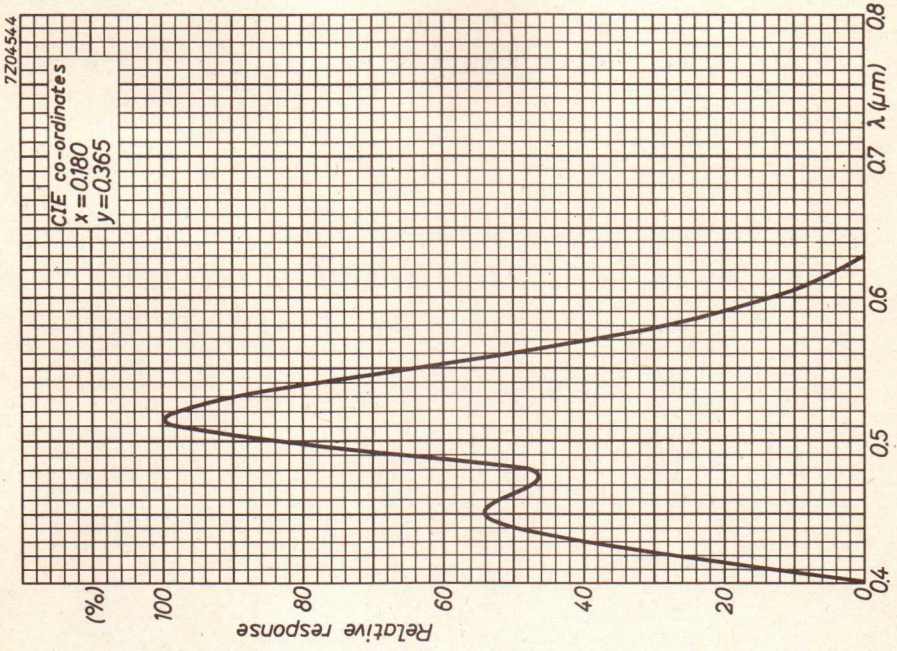

GP screen

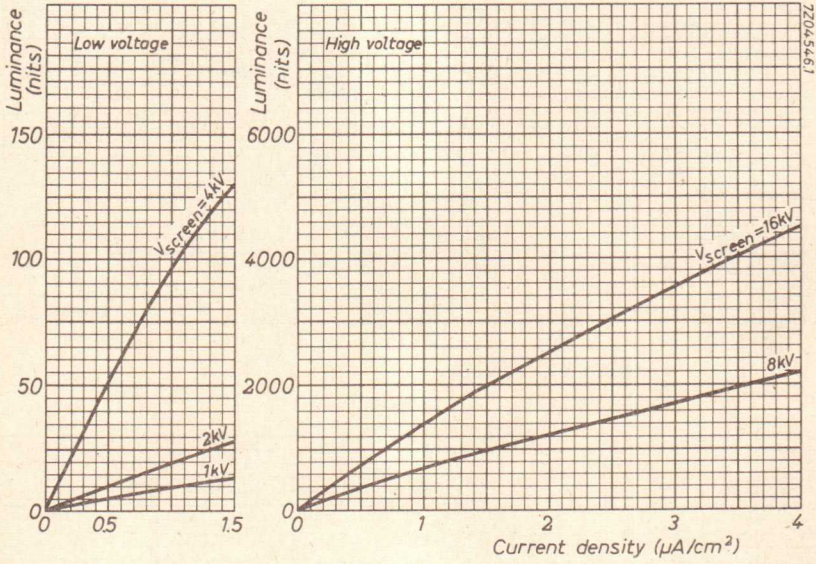

7211083

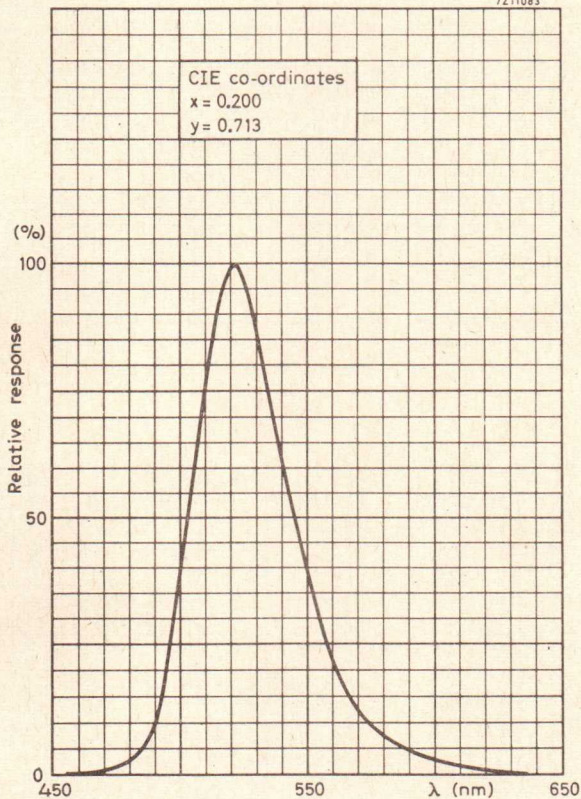

GR screen

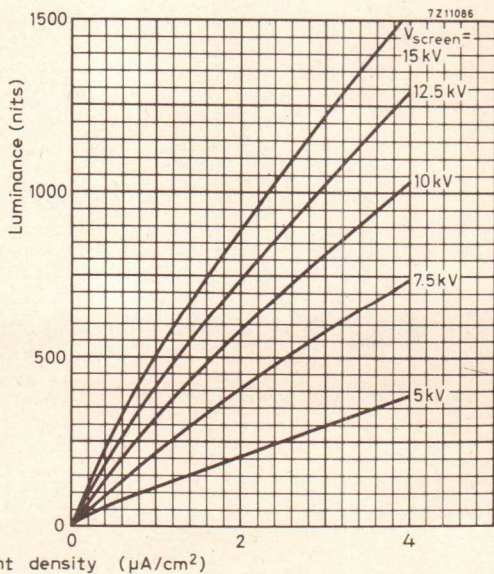
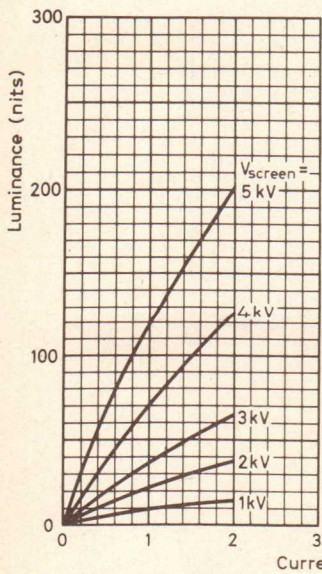
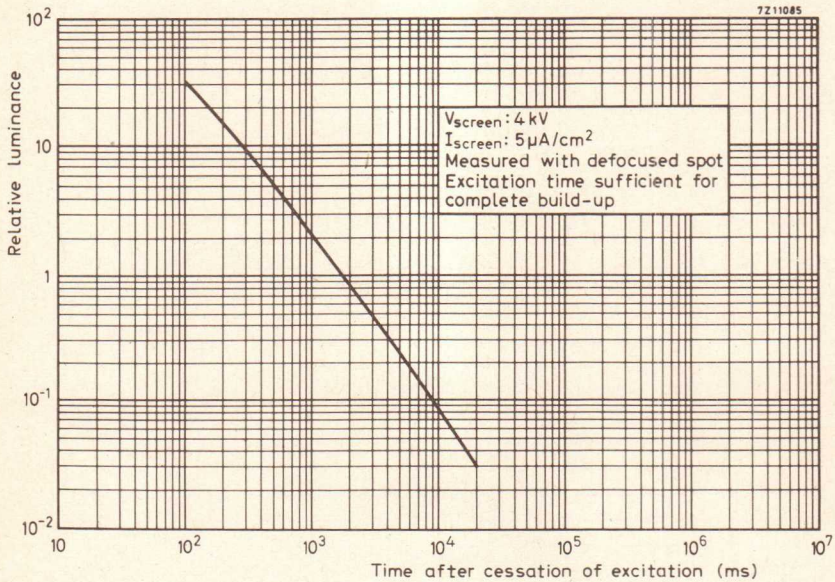

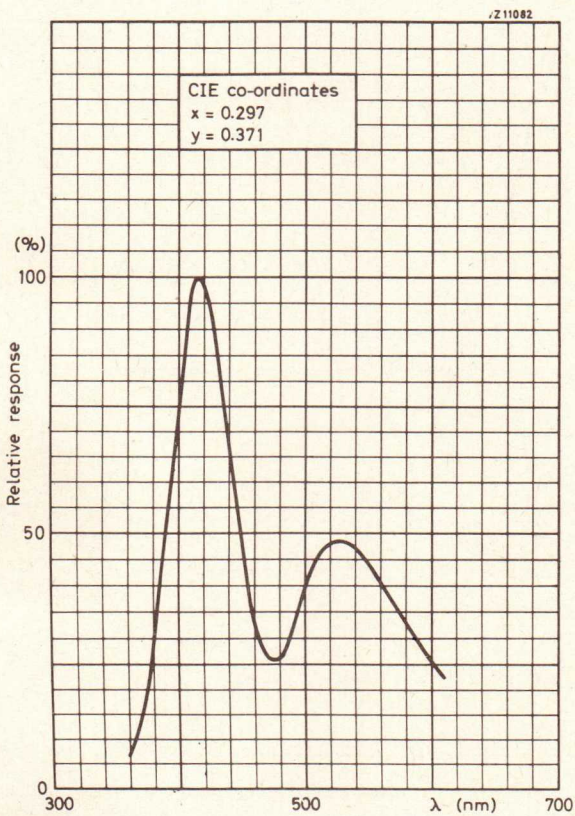

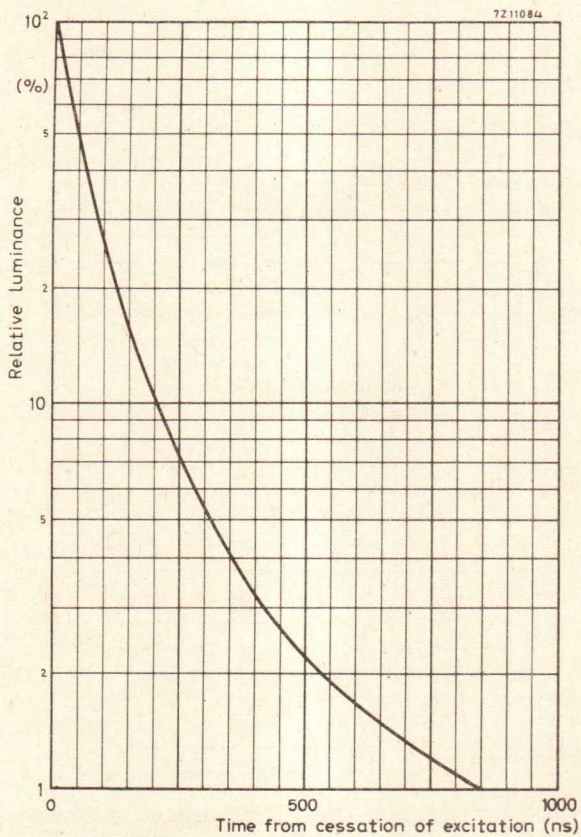

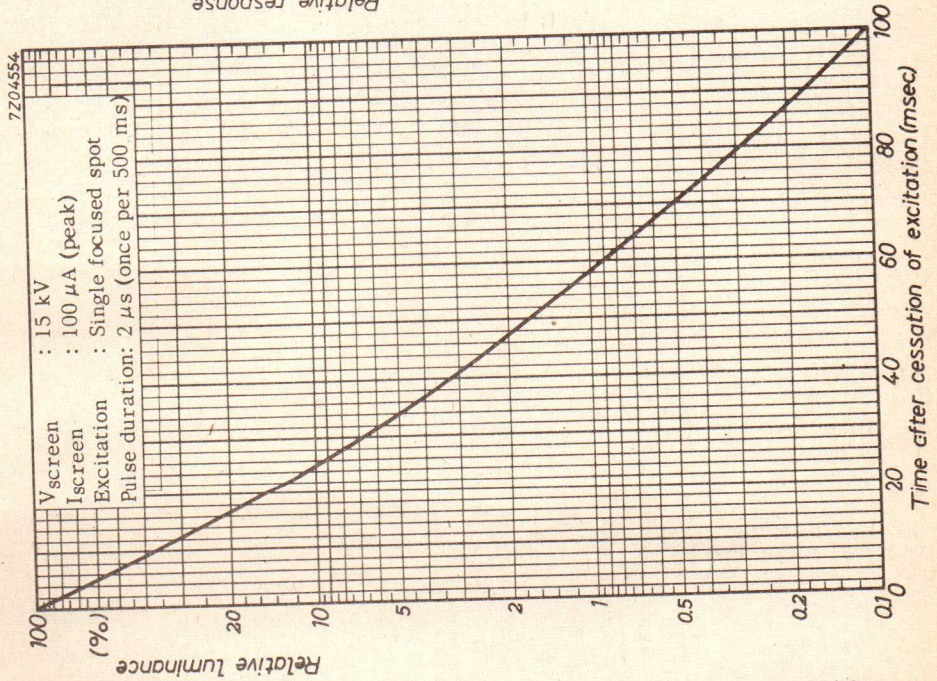
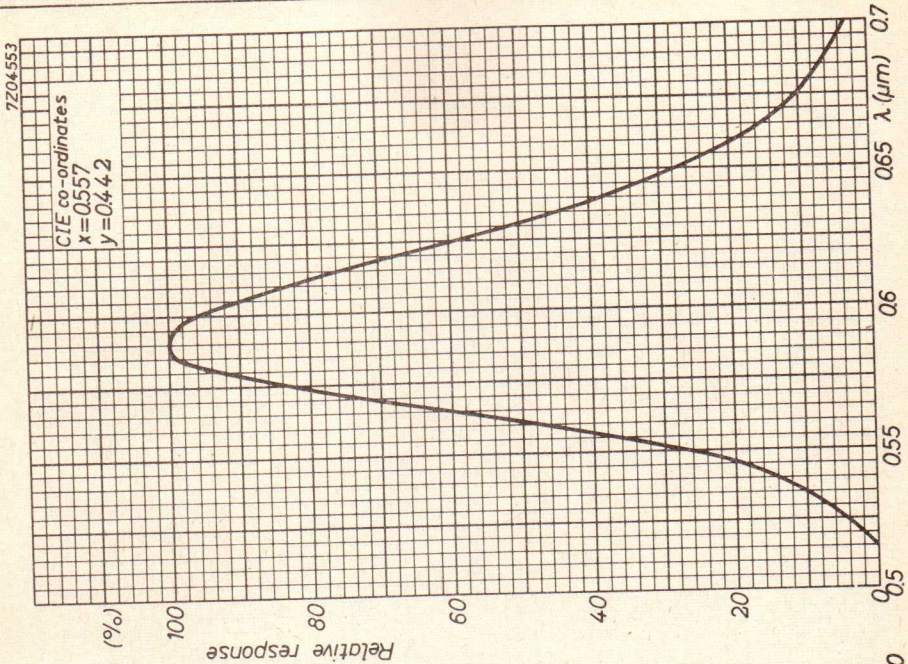

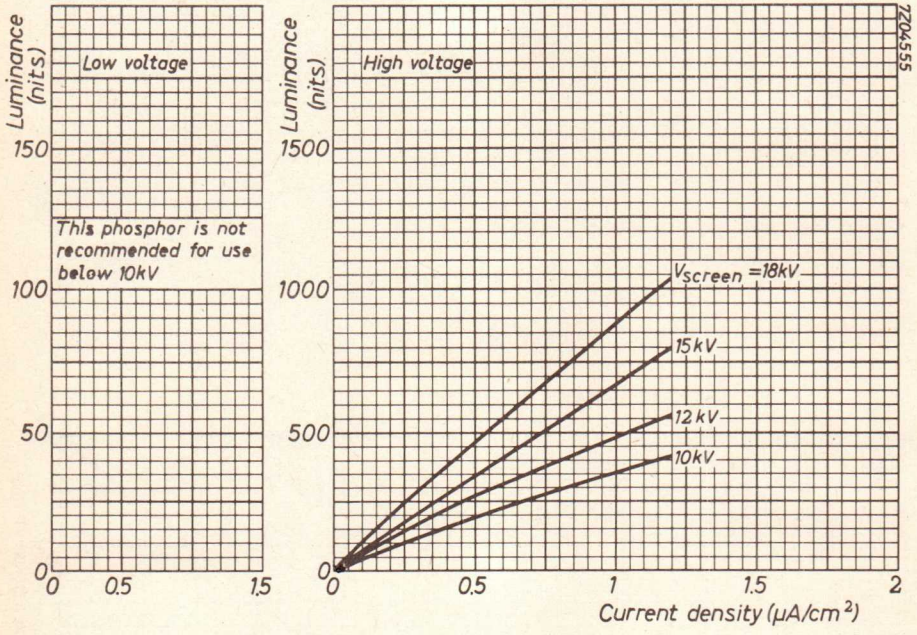

7204556

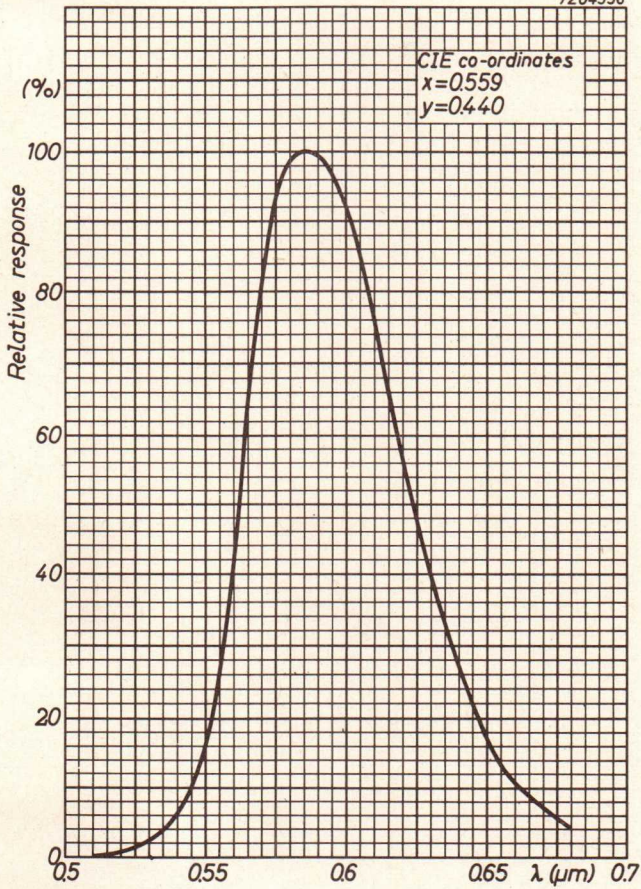

7204597

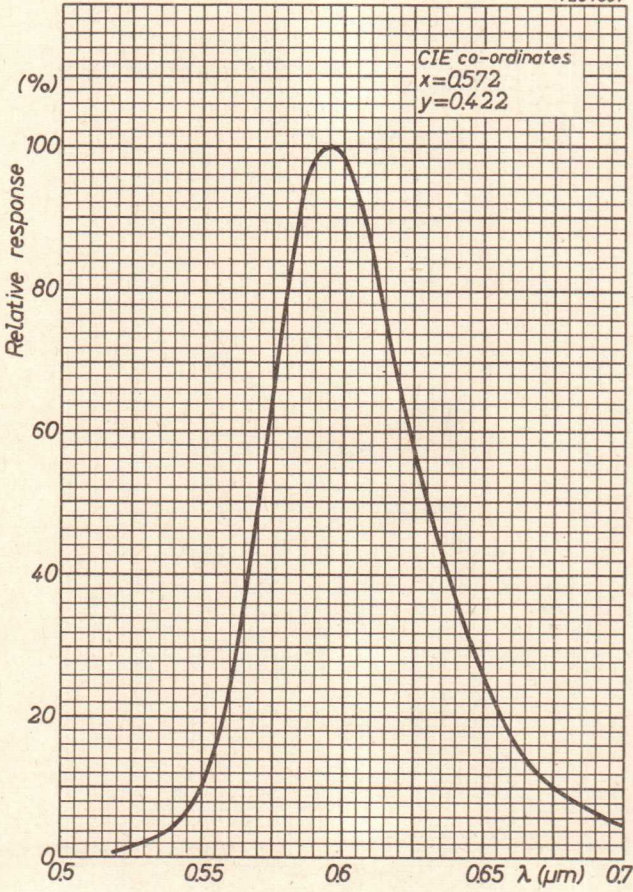

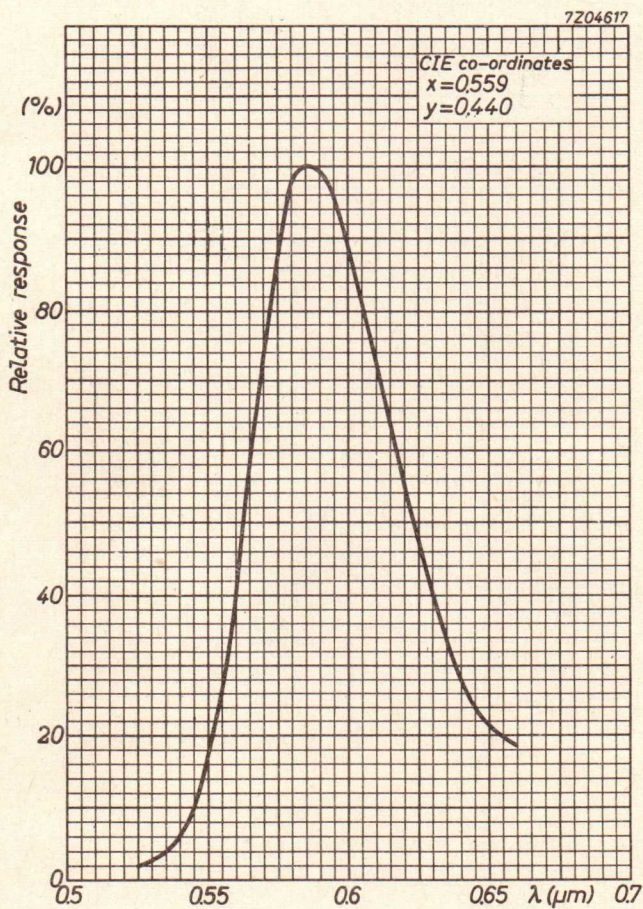

7204628.1

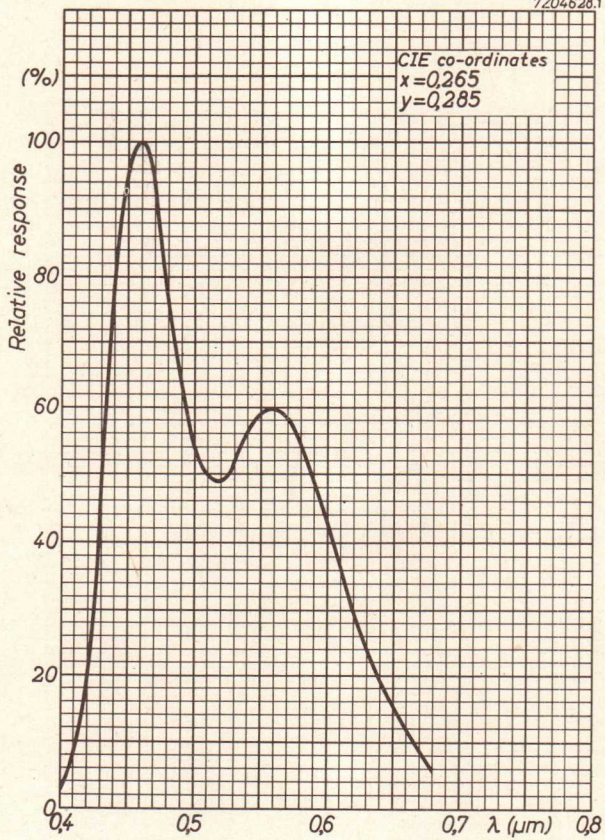

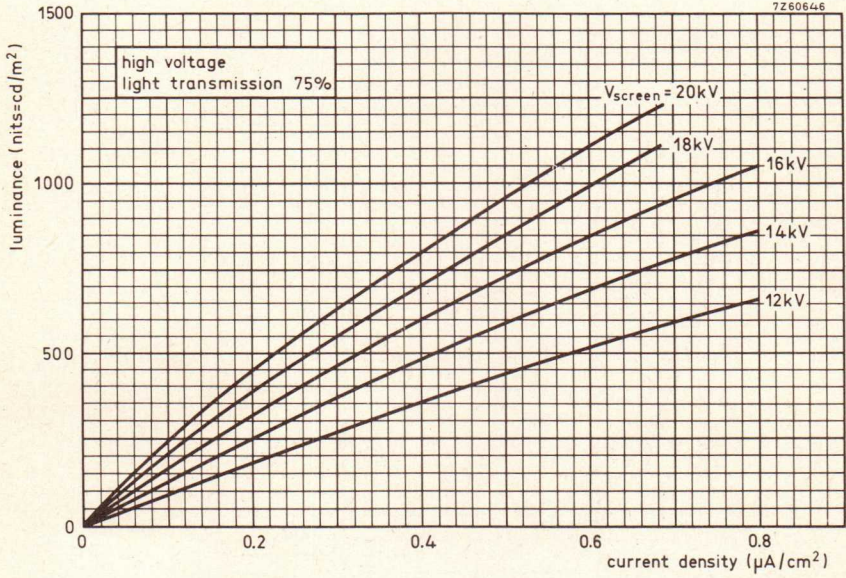

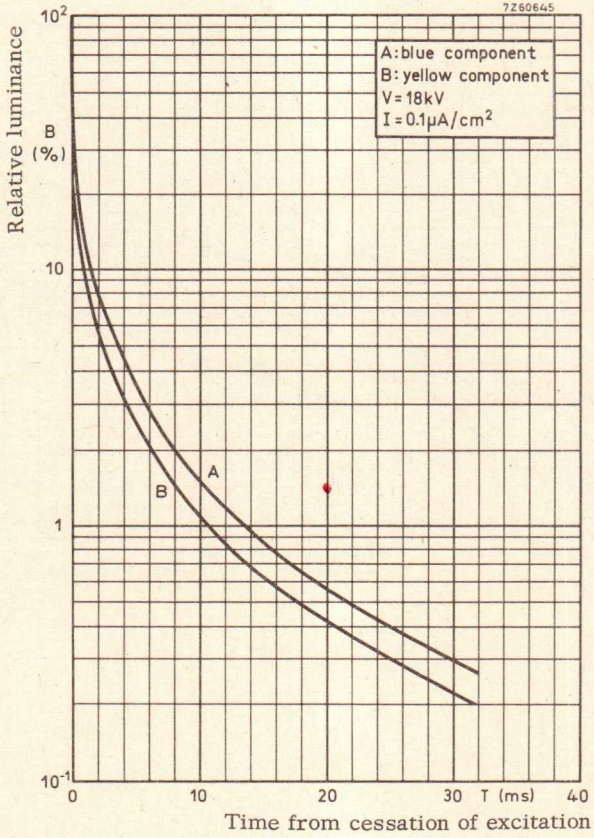

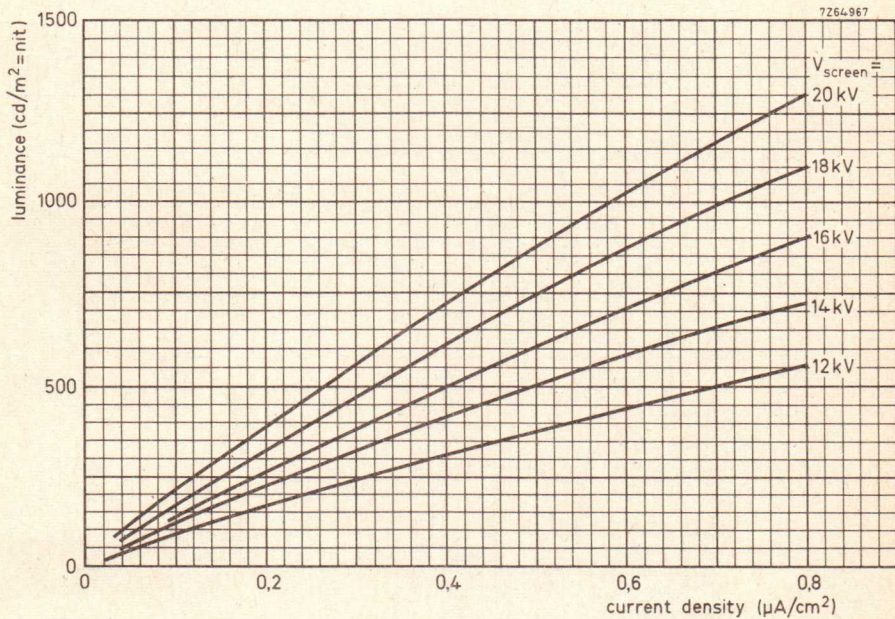

7264 966

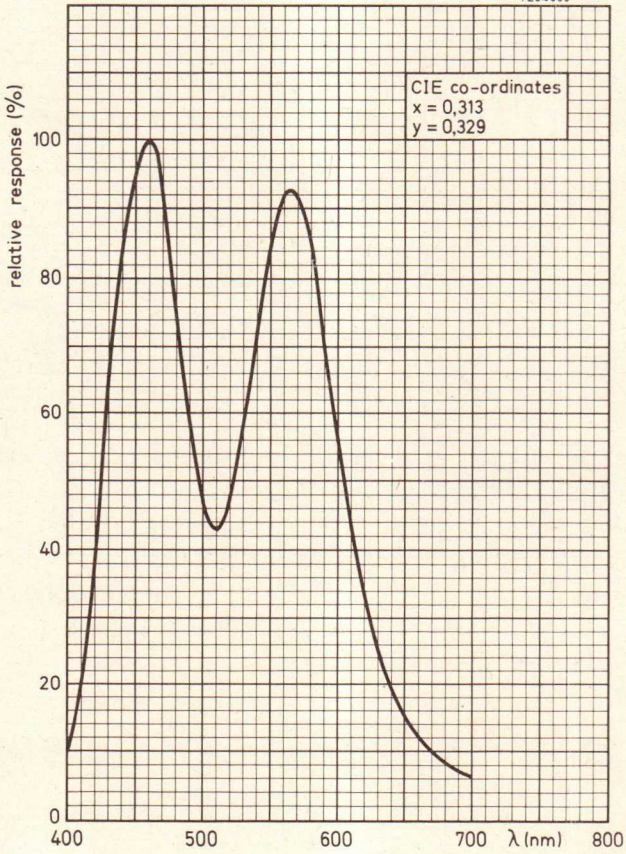

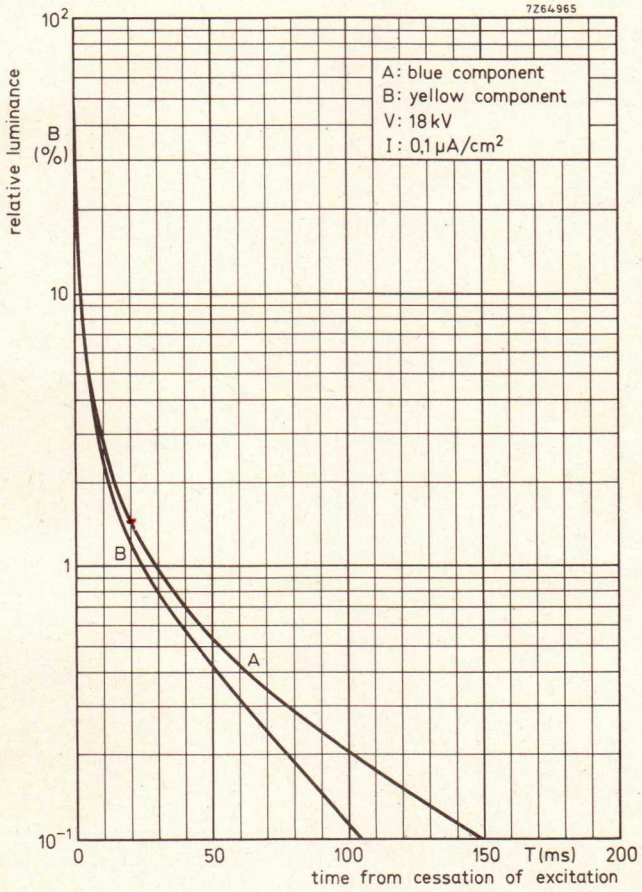

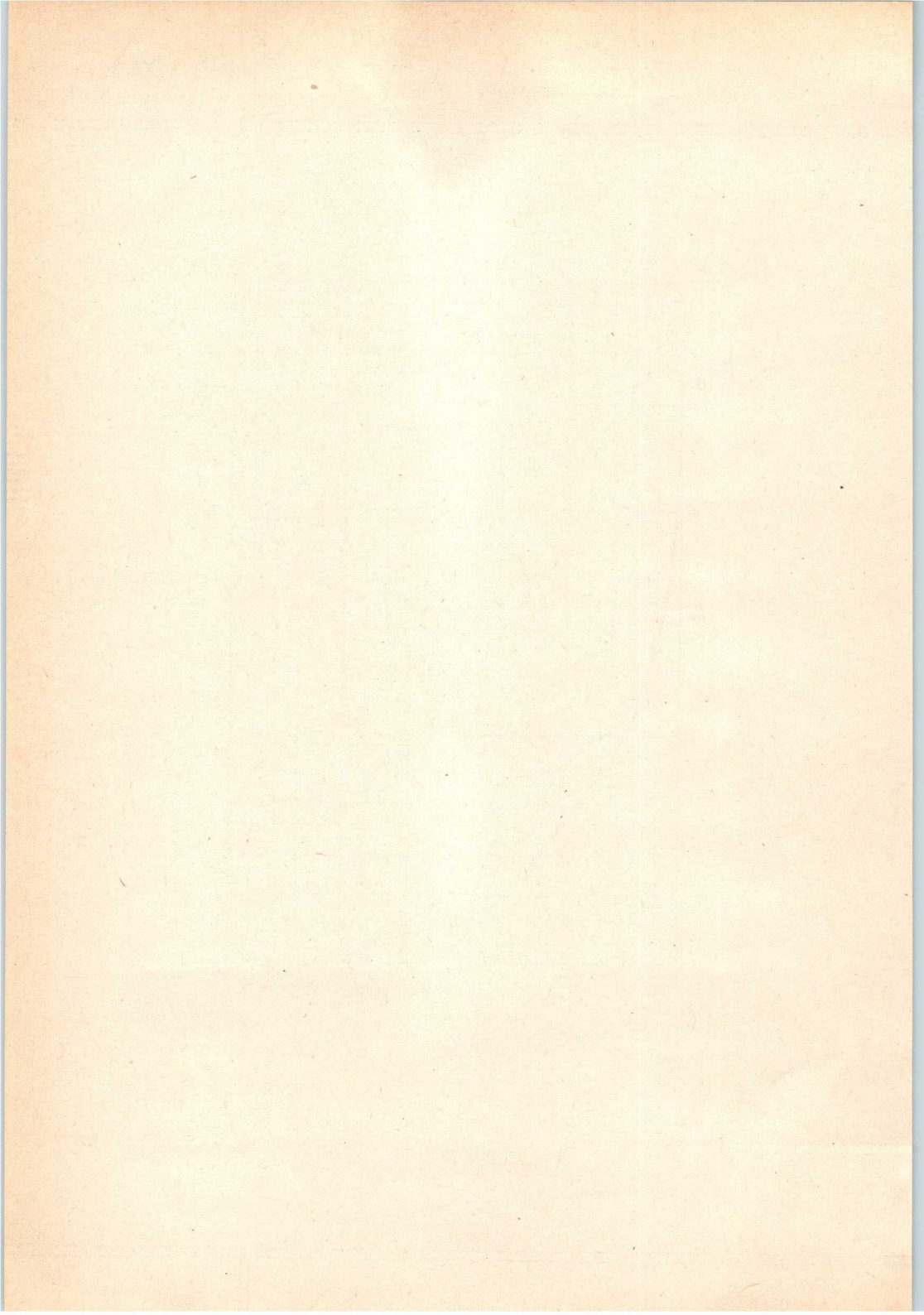

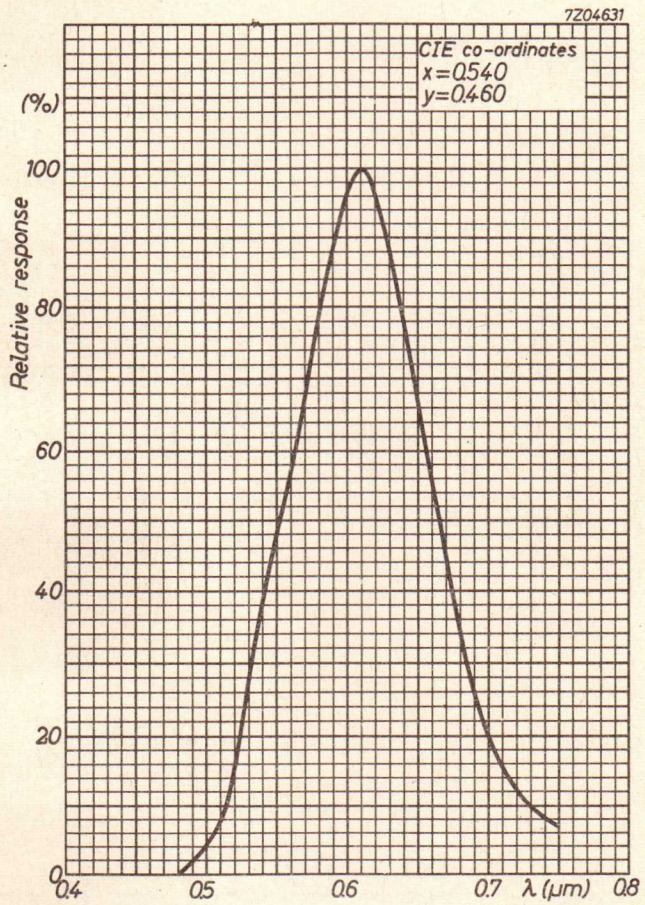

GH screen

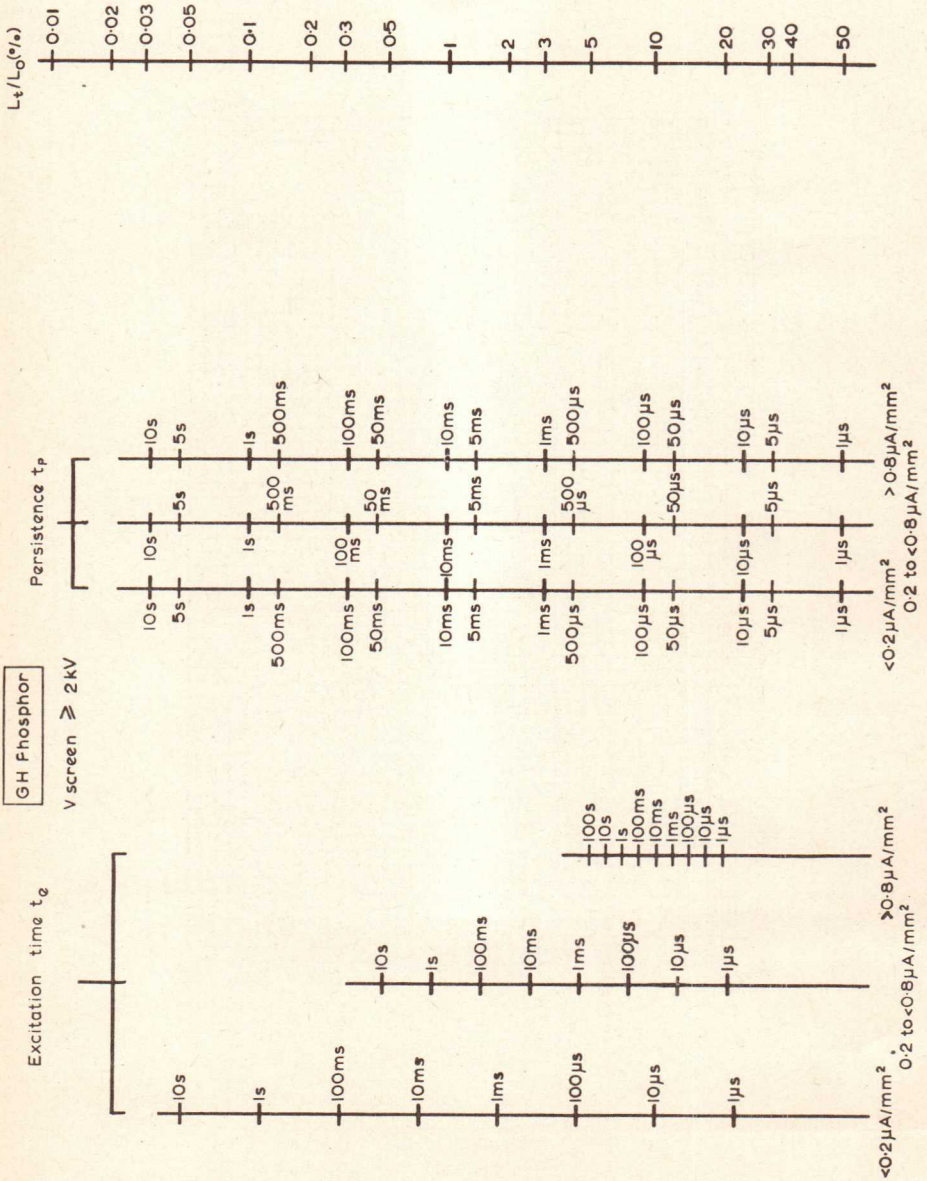

Instrument tubes



INSTRUMENT TUBES

PREFERRED TYPES

(Recommended types for new designs)

Mono-accelerator tubes	D7-190	D7-191..
	D7-220..+	D7-221..+
	D13-480..	D13-481..
	D14-250	D14-251
	DG7-31	
	DG7-32	

Post-deflection accelerator tubes	D14-120GH
	D14-121GH
	D14-162GH/09
	D14-260GH+
	E14-100GH

Large bandwidth instrument tubes	D13-500../01
	D14-240GH/37

Direct-view storage tube	L14-110GH/55
	L14-130GH/55+

INSTRUMENT CATHODE-RAY TUBE

7 cm diameter flat faced monoaccelerator oscilloscope tube primarily intended for use in inexpensive oscilloscopes and monitoring devices.

QUICK REFERENCE DATA

Accelerator voltage	$V_{g2, g4, g5, l}$	1000	V
Display area		60 x 50	mm ²
Deflection coefficient, horizontal	M_x	29	V/cm
	vertical	M_y	11.5 V/cm

SCREEN

	colour	persistence
D7-190GH	green	medium short
D7-190GM	yellowish green	long

Useful screen diameter min. 64 mm

Useful scan

horizontal min. 60 mm

vertical min. 50 mm

The useful scan may be shifted vertically to a maximum of 4mm with respect to the geometric centre of the faceplate.

HEATING: Indirect by A.C. or D.C.; parallel supply

Heater voltage $\frac{V_f}{\quad}$ 6.3 V

Heater current I_f 300 mA

MECHANICAL DATA (Dimensions in mm)

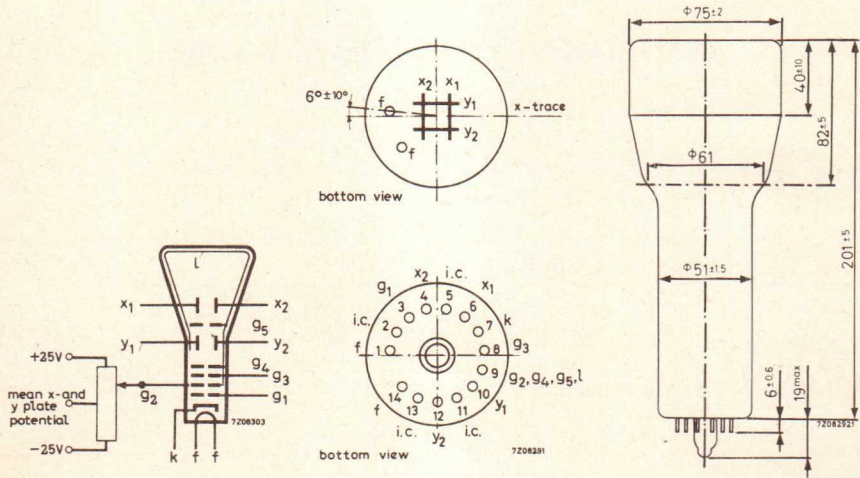

Mounting position: any

The tube should not be supported by the base alone and under no circumstances should the socket be allowed to support the tube.

Dimensions and connections

See also outline drawing

Overall length max. 225 mm

Face diameter max. 77 mm

Base 14 pin all glass

Net weight approx. 260 g

Accessories

Socket (supplied with tube) type 55566

Mu-metal shield type 55534

CAPACITANCES

x_1 to all other elements except x_2	$C_{x1(x2)}$	4	pF
x_2 to all other elements except x_1	$C_{x2(x1)}$	4	pF
y_1 to all other elements except y_2	$C_{y1(y2)}$	3.5	pF
y_2 to all other elements except y_1	$C_{y2(y1)}$	3	pF
x_1 to x_2	C_{x1x2}	1.6	pF
y_1 to y_2	C_{y1y2}	1.1	pF
Control grid to all other elements	C_{g1}	5.5	pF
Cathode to all other elements	C_k	4.0	pF

FOCUSING electrostatic

DEFLECTION 3) double electrostatic

x plates symmetrical

y plates symmetrical

If use is made of the full deflection capabilities of the tube the deflection plates will intercept part of the electron beam, hence a low impedance deflection plate drive is desirable.

Angle between x and y traces $90 \pm 1^\circ$

LINE WIDTH 3)

Measured with the shrinking raster method in the centre of the screen under typical operating conditions, adjusted for optimum spot size at a beam current $I_l = 10 \mu A$. 1)

Line width l. w. 0.28 mm

1) As the construction of this tube does not permit a direct measurement of the beam current, this current should be determined as follows:

a) under typical operating conditions, apply a small raster display (no overscan), adjust V_{g1} for a beam current of approx. $10 \mu A$ and adjust V_{g3} and $V_{g2, g4, g5, l}$ for optimum spot quality at the centre of the screen.

b) under these conditions, but no raster, the deflection plate voltages should be changed to

$V_{y1} = V_{y2} = 1000 V$; $V_{x1} = 300 V$; $V_{x2} = 700 V$, thus directing the total beam current to x_2 .

Measure the current on x_2 and adjust V_{g1} for $I_{x2} = 10 \mu A$ (being the beam current I_l)

c) set again for the conditions under a), without touching the V_{g1} control. Now a raster display with a true $10 \mu A$ screen current is achieved.

d) focus optimally in the centre of the screen (do not adjust the astigmatism control) and measure the line width.

3) See page 4

TYPICAL OPERATING CONDITIONS ³⁾

Accelerator voltage	$V_{g2, g4, g5, \ell}$	1000 V
Astigmatism control voltage	$\Delta V_{g2, g4, g5, \ell}$	± 25 V ¹⁾
Focusing electrode voltage	V_{g3}	100 to 180 V
Control grid voltage for visual extinction of focused spot	V_{g1}	max. -35 V
Grid drive for 10 μ A screen current		approx. 10 V
Deflection coefficient, horizontal	M_x	29 V/cm
		max. 31 V/cm
vertical	M_y	11.5 V/cm
		max. 12.5 V/cm
Deviation of linearity of deflection		max. 1% ²⁾ <i>2!</i>
Geometry distortion		see note 4
Useful scan, horizontal		min. 60 mm
	vertical	min. 50 mm

LIMITING VALUES (Absolute max. rating system)

Accelerator voltage	$V_{g2, g4, g5, \ell}$	max. 2200 V
		min. 900 V
Focusing electrode voltage	V_{g3}	max. 2200 V
Control grid voltage, negative	$-V_{g1}$	max. 200 V
		min. 0 V
Cathode to heater voltage	V_{kf}	max. 125 V
		$-V_{kf}$ max. 125 V
Grid drive, average		max. 20 V
Screen dissipation	W_{ℓ}	max. 3 mW/cm ²

- 1) All that will be necessary when putting the tube into operation is to adjust the astigmatism control voltage once for optimum spot shape in the screen centre. The control voltage will always be in the range stated, provided the mean x plate and certainly the mean y plate potential was made equal to $V_{g2, g4, g5, \ell}$ with zero astigmatism correction.
- 2) The sensitivity at a deflection of less than 75% of the useful scan will not differ from the sensitivity at a deflection of 25% of the useful scan by more than the indicated value.
- 3) The mean x and certainly the mean y plate potential should be equal to $V_{g2, g4, g5, \ell}$ with astigmatism adjustment set to zero.
- 4) A graticule, consisting of concentric rectangles of 40 mm x 50 mm and 39.2 mm x 49 mm is aligned with the electrical x-axis of the tube. The edges of a raster will fall between these rectangles.

INSTRUMENT CATHODE-RAY TUBE

7 cm diameter flat faced mono accelerator oscilloscope tube with low heater consumption.

QUICK REFERENCE DATA

Accelerator voltage	$V_{g2, g4, g5(\ell)}$	1000	V
Display area		60 x 50	mm ²
Deflection coefficient, horizontal	M_x	29	V/cm
	vertical	M_y	11,5 V/cm

The D7-191 is equivalent to the type D7-190.. except for the following

HEATING: Indirect by a. c. or d. c. ; parallel supply.

Heater voltage	V_f	6,3	V
Heater current	I_f	95	mA

LIMITING VALUES (Absolute max. rating system)

Cathode to heater voltage, positive	$V_{k/f}$	max.	100	V
	negative	$-V_{k/f}$	max.	15

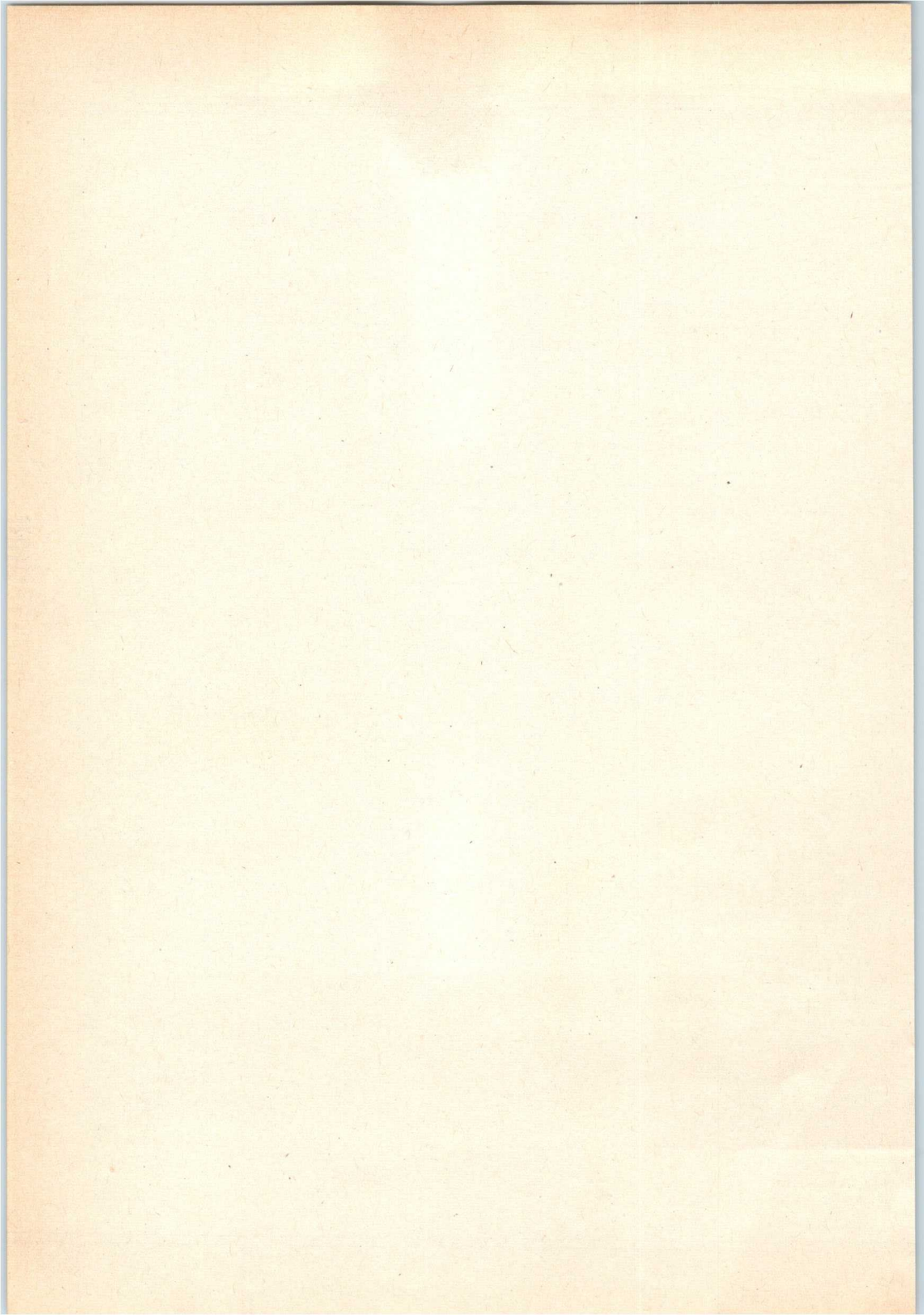

INSTRUMENT CATHODE-RAY TUBE

10 cm diameter flat faced monoaccelerator oscilloscope tube primarily intended for use in inexpensive oscilloscopes and read-out devices.

QUICK REFERENCE DATA

Accelerator voltage	$V_{g2, g4, g5(l)}$	1500 V
Display area		80 x 60 mm ²
Deflection coefficient, horizontal	M_x	32 V/cm
vertical	M_y	13.7 V/cm

SCREEN

	colour	persistence
D10-160GH	green	medium short
D10-160GM	yellowish green	long

Useful screen diameter min. 85 mm

Useful scan

horizontal min. 80 mm

vertical min. 60 mm

The useful scan may be shifted vertically to a max. of 5 mm with respect to the geometric centre of the faceplate.

HEATING: Indirect by A.C. or D.C.; parallel supply

Heater voltage	V_f	6.3 V
Heater current	I_f	300 mA

→ MECHANICAL DATA (Dimensions in mm)

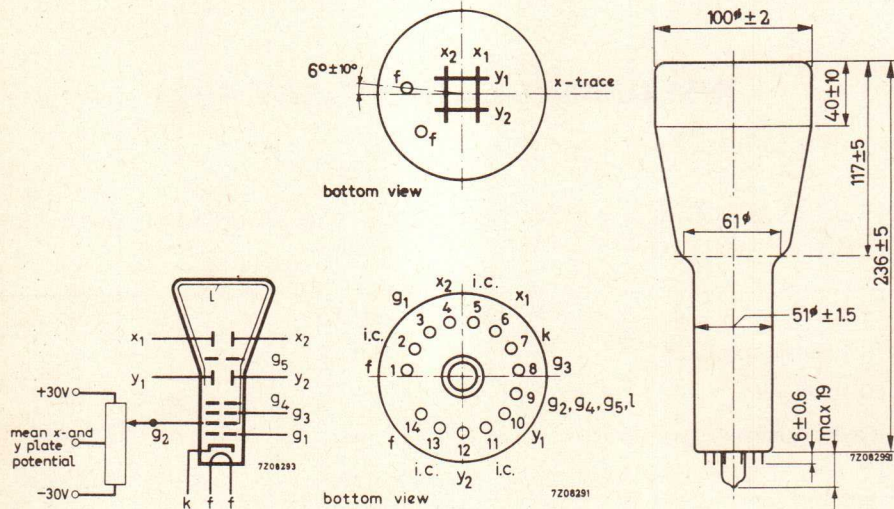

Mounting position: any

The tube should not be supported by the base alone and under no circumstances should the socket be allowed to support the tube.

Dimensions and connections

See also outline drawing

Overall length max. 260 mm

Face diameter max. 102 mm

Base 14 pin all glass

Net weight approx. 400 g

Accessories

Socket (supplied with tube) type 55566

Mu metal shield type 55547

CAPACITANCES

x_1 to all other elements except x_2	$C_{x1(x2)}$	4	pF
x_2 to all other elements except x_1	$C_{x2(x1)}$	4	pF
y_1 to all other elements except y_2	$C_{y1(y2)}$	3.5	pF
y_2 to all other elements except y_1	$C_{y2(y1)}$	3	pF
x_1 to x_2	C_{x1x2}	1.6	pF
y_1 to y_2	C_{y1y2}	1.1	pF
Control grid to all other elements	C_{g1}	5.5	pF
Cathode to all other elements	C_k	4	pF

FOCUSING electrostatic**DEFLECTION** 3) double electrostatic

x plates symmetrical

y plates symmetrical

If use is made of the full deflection capabilities of the tube the deflection plates will intercept part of the electron beam, hence a low impedance deflection plate drive is desirable.

Angle between x and y traces $90 \pm 1^\circ$ **LINE WIDTH**

Measured with the shrinking raster method in the centre of the screen under typical operating conditions, adjusted for optimum spot size at a beam current $I_b = 10 \mu A$. 1)

Line width l.w. 0.27 mm

1) As the construction of this tube does not permit a direct measurement of the beam current, this current should be determined as follows:

a) under typical operating conditions, apply a small raster display (no overscan), adjust V_{g1} for a beam current of approx. $10 \mu A$ and adjust V_{g3} and $V_{g2, g4, g5, l}$ for optimum spot quality at the centre of the screen.

b) under these conditions, but no raster, the deflection plate voltages should be changed to

$V_{y1} = V_{y2} = 1500 \text{ V}$; $V_{x1} = 800 \text{ V}$; $V_{x2} = 1200 \text{ V}$, thus directing the total beam current to x_2 .

Measure the current on x_2 and adjust V_{g1} for $I_{x2} = 10 \mu A$ (being the beam current I_b)

c) set again for the conditions under a), without touching the V_{g1} control. Now a raster display with a true $10 \mu A$ screen current is achieved.

d) focus optimally in the centre of the screen (do not adjust the astigmatism control) and measure the line width.

3) See page 4

TYPICAL OPERATING CONDITIONS³⁾

Accelerator voltage	$V_{g2,g4,g5,l}$	1500 V
Astigmatism control voltage	$\Delta V_{g2,g4,g5,l}$	± 30 V ¹⁾
Focusing electrode voltage	V_{g3}	140 to 275 V
Control grid voltage for visual extinction of focused spot	V_{g1}	max. -50 V
Grid drive for 10 μ A screen current		approx. 10 V
Deflection coefficient, horizontal	M_x	32 V/cm
		max. 34 V/cm
vertical	M_y	13.7 V/cm
		max. 14.5 V/cm
Deviation of linearity of deflection		max. 1 % ²⁾
Geometry distortion		see note 4
Useful scan, horizontal		min. 80 mm
		vertical

LIMITING VALUES (Absolute max. rating system)

Accelerator voltage	$V_{g2,g4,g5,l}$	max. 2200 V
		min. 1350 V
Focusing electrode voltage	V_{g3}	max. 2200 V
Control grid voltage, negative	$-V_{g1}$	max. 200 V
		min. 0 V
Cathode to heater voltage	V_{kf}	max. 125 V
		$-V_{kf}$
Grid drive, average		max. 20 V
Screen dissipation	W_l	max. 3 mW/cm ²

- 1) All that will be necessary when putting the tube into operation is to adjust the astigmatism control voltage once for optimum spot shape in the screen centre. The control voltage will always be in the range stated, provided the mean x plate and certainly the mean y plate potential was made equal to $V_{g2,g4,g5,l}$ with zero astigmatism correction.
- 2) The sensitivity at a deflection of less than 75% of the useful scan will not differ from the sensitivity at a deflection of 25% of the useful scan by more than the indicated value.
- 3) The mean x and certainly the mean y plate potentials should be equal to $V_{g2,g4,g5,l}$ with astigmatism adjustment set to zero.
- 4) A graticule, consisting of concentric rectangles of 50 mm x 60 mm and 49 mm x 58.6 mm is aligned with the electrical x-axis of the tube. The edges of a raster will fall between these rectangles.

INSTRUMENT CATHODE-RAY TUBE

10 cm diameter flat faced monoaccelerator oscilloscopetube with low heater consumption.

QUICK REFERENCE DATA		
Accelerator voltage	$V_{g2, g4, g5(l)}$	1500 V
Display area		80 x 60 mm ²
Deflection coefficient, horizontal	M_x	32 V/cm
vertical	M_y	13.7 V/cm

The D10-161.. is equivalent to the type D10-160.. except for the following:

HEATING: Indirect by A.C. or D.C.; parallel supply

Heater voltage	V_f	6.3 V
Heater current	I_f	95 mA

LIMITING VALUES (Absolute max. rating system)

Cathode to heater voltage

Cathode positive	$V+k/f-$	max. 100 V
Cathode negative	$V-k/f+$	max. 15 V

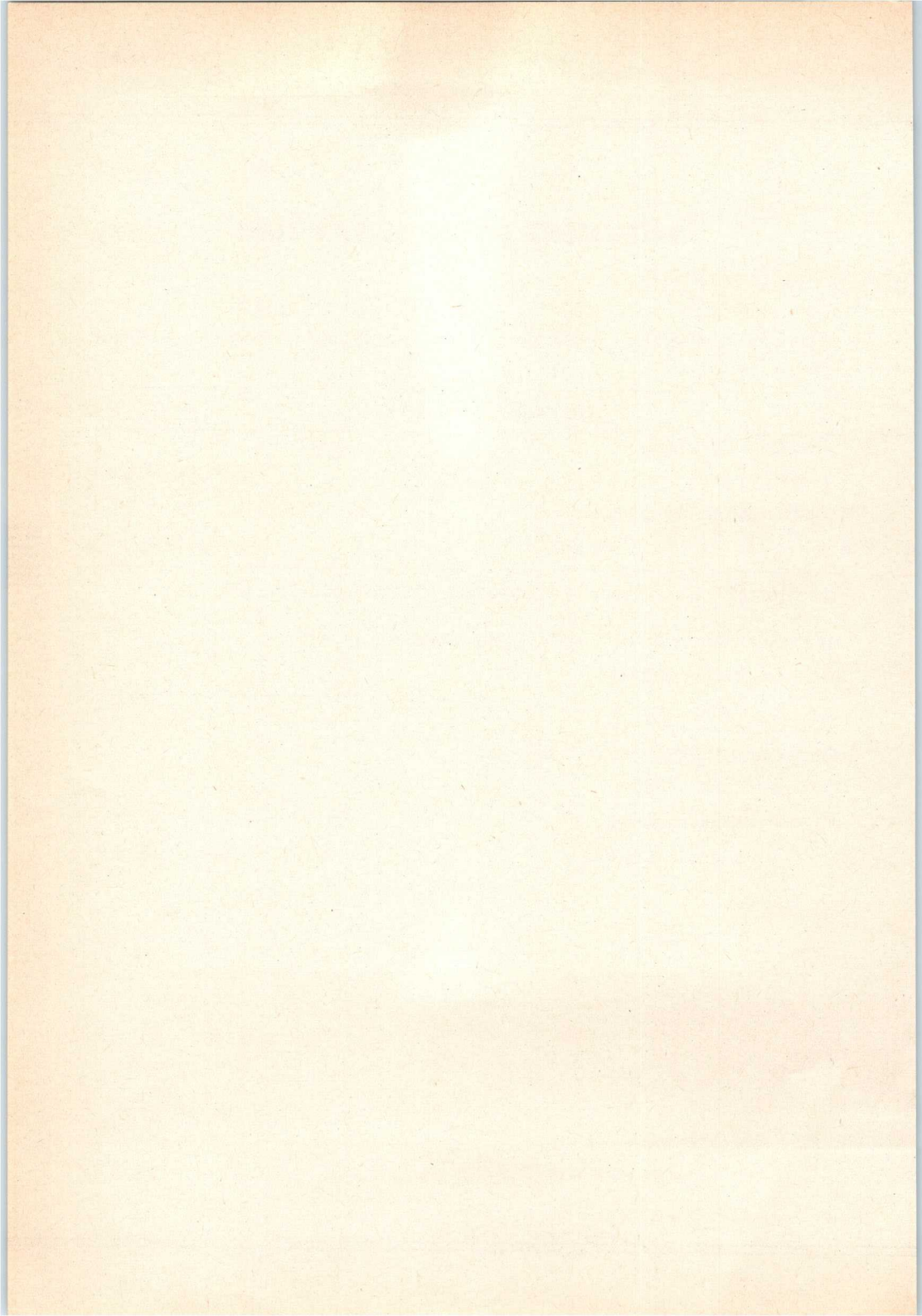

INSTRUMENT CATHODE-RAY TUBE

10 cm diameter flat faced oscilloscope tube with mesh, designed for compact, transistorized oscilloscopes of 10 MHz to 30 MHz bandwidth.

QUICK REFERENCE DATA

Final accelerator voltage	$V_{g7(\ell)}$	6	kV
Display area		80 x 60	mm ²
Deflection coefficient, horizontal	M_x	13	V/cm
	vertical	M_y	3,5 V/cm

SCREEN

	colour	persistence
D10-170GH	green	medium short

Useful screen diameter min. 85 mm

Useful scan at $V_{g7(\ell)}/V_{g2}, g_4 = 6$

horizontal min. 80 mm

vertical min. 60 mm

The useful scan may be found shifted vertically to a max. of 5 mm with respect to the geometric centre of the faceplate.

HEATING: Indirect by a. c. or d. c. ; parallel supply

Heater voltage V_f 6,3 V

Heater current I_f 300 mA

MECHANICAL DATA

Dimensions in mm

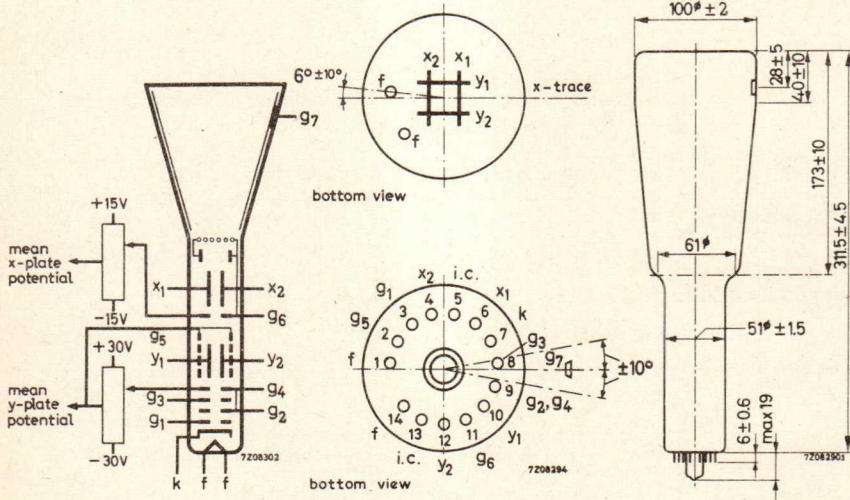

Mounting position: any

The tube should not be supported by the base alone and under no circumstances should the socket be allowed to support the tube.

Dimensions and connections

See also outline drawing

Overall length (socket included) max. 335 mm

Face diameter max. 102 mm

Net weight approx. 500 g

Base 14 pin all glass

Accessories

Socket (supplied with tube) type 55566

Final accelerator contact connector type 55563A

Mu-metal shield type 55548

Notes

1) This tube is designed for optimum performance when operating at a ratio

$$V_{g7}/V_{g2}, g_4 = 6 .$$

The geometry electrode voltage should be adjusted within the indicated range (values with respect to the mean x-plate potential). A negative control voltage will cause some pincushion distortion and less background light, a positive control voltage will give some barrel distortion and a slight increase of background light.

2) The deflection plate shield voltage should be equal to the mean y-plate potential. The mean x- and y-plate potentials should be equal for optimum spot quality.

3) The astigmatism control electrode voltage should be adjusted for optimum spot shape. For any necessary adjustment its potential will be within the stated range.

4) The sensitivity at a deflection of less than 75% of the useful scan will not differ from the sensitivity at a deflection of 25% of the useful scan by more than the indicated value.

5) A graticule, consisting of concentric rectangles of 60 mm x 60 mm and 58.6 mm x 58.6 mm, is aligned with the electrical x-axis of the tube.

With optimum correction potentials applied the edges of a raster lie between these rectangles.

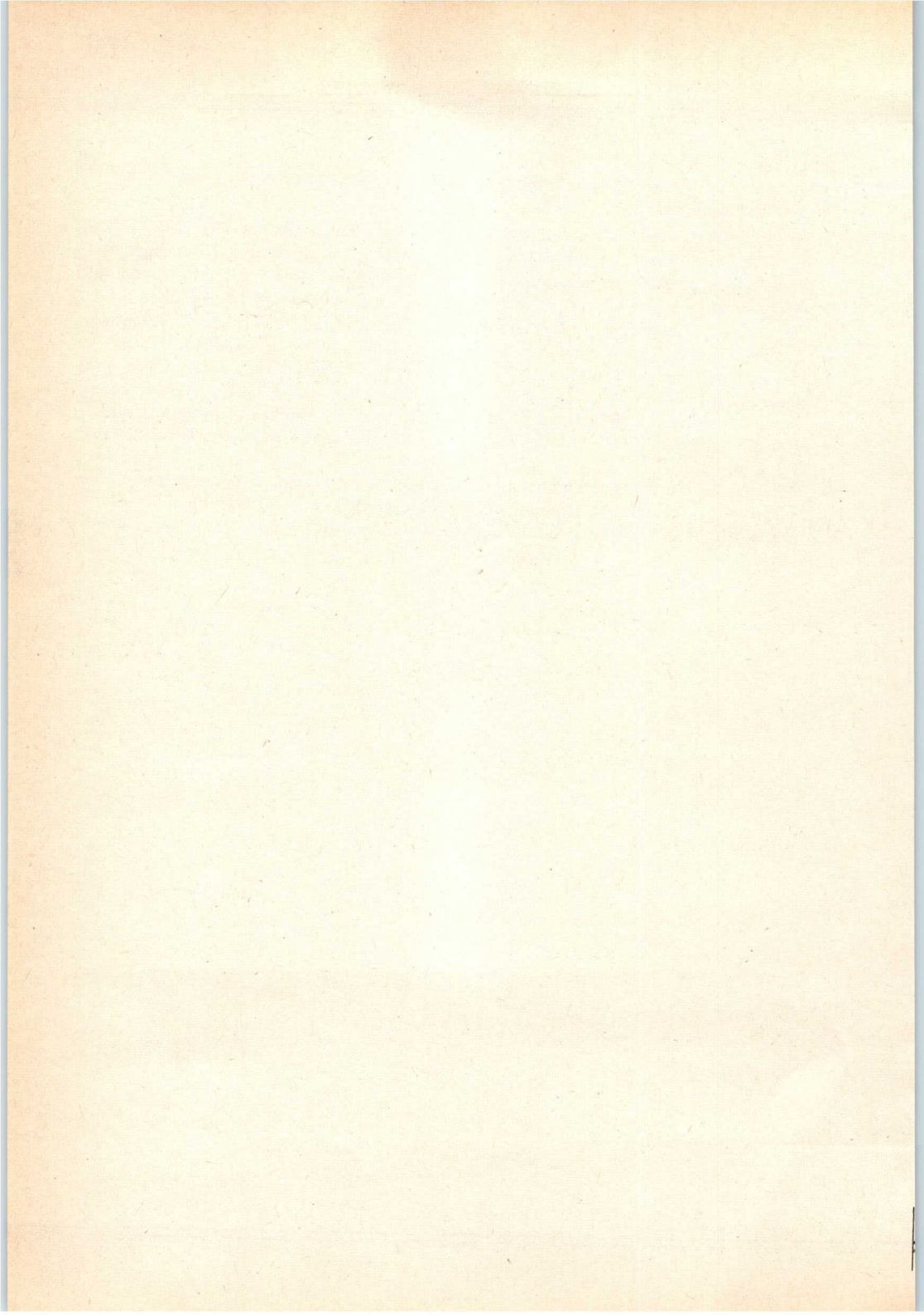

MECHANICAL DATA(continued)

Base 14 pin all glass

Accessories

Socket (supplied with tube) type 55566

FOCUSING electrostatic

DEFLECTION double electrostatic

x plates symmetrical

y plates symmetrical

If use is made of the full deflection capabilities of the tube the deflection plates will intercept part of the electron beam near the edge of the scan, hence a low impedance deflection plate drive is desirable.

Angle between x and y traces 90°

TYPICAL OPERATING CONDITIONS

Final accelerator voltage	$V_{g_9(\ell)}$	=	10 000 V
Geometry control electrode voltage	V_{g_8}	=	1670 ± 100 V
Deflection plate shield voltage	V_{g_7}	=	1670 V
Beam centring electrode voltage	V_{g_6}	=	1670 ± 20 V
Astigmatism control electrode voltage	V_{g_5}	=	1670 ± 100 V
Focusing electrode voltage	V_{g_4}	=	230 to 500 V
Deflection blanking electrode voltage	V_{g_3}	=	1670 V
Deflection blanking control voltage	ΔV_{g_3}	=	max. 60 V
First accelerator voltage	V_{g_2}	=	1670 V
Control grid voltage for visual extinction of focused spot	$-V_{g_1}$	=	50 to 120 V
Deflection coefficient			
horizontal	M_x	=	max. 18 V/cm
vertical	M_y	=	5.6 to 6.6 V/cm
Deviation of linearity of deflection		=	max. 2 %
Useful scan			
horizontal		=	100 mm
vertical		=	60 mm

INSTRUMENT CATHODE-RAY TUBE

The D13-16../01 is equivalent to the D13-16.. but features an internal graticule. This graticule can be illuminated.

MECHANICAL DATA

Dimensions in mm

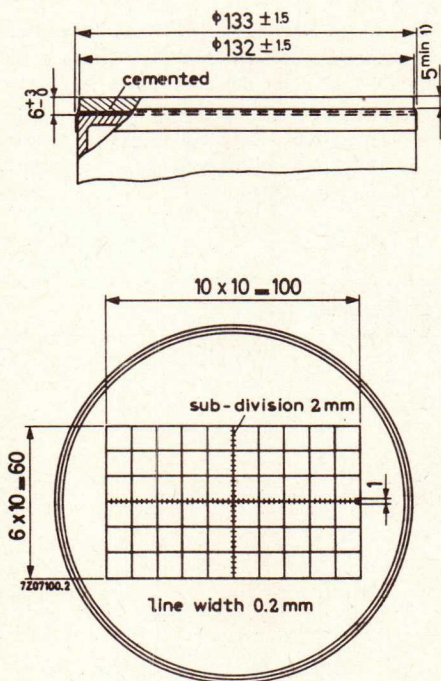

Maximum angle between x-trace and
· x-axis of the graticule

 $\pm 5^\circ$

1) Clear area for light conductor.

ALIGNMENT

In order to align the x-trace and the x-axis of the graticule an image rotating coil may be used. This coil should be positioned at one third of the cone length, seen from the face end, and can be attached to the inner surface of the mu-metal shield.

Under typical operating conditions maximum 50 ampere-turns are required for alignment.

ILLUMINATION

To illuminate the internal graticule the use of a light conductor (e.g. of Perspex) is obligatory. The following design considerations should be observed:

In order to achieve the most efficient light conductance the holes for the light bulb as well as the contact area with the front plate should be polished. The contact with the edges of the front plate should be as close as possible and the edges of the front plate and the corresponding hole in the light conductor should be parallel to achieve light beams perpendicular to the edges. It is advised to apply reflective material to the outer circumference of the conductor and if possible also to both planes (see drawing).

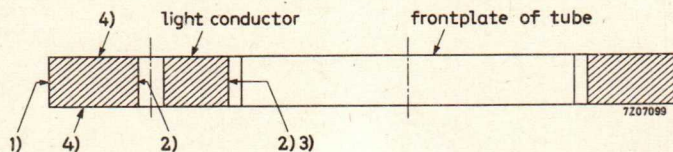

1) Reflective material.

2) Polished.

3) Close and constant distance to front plate of tube.

It is essential that the light conductor and the front plate of the tube are in plane.

4) If possible reflective material.

INSTRUMENT CATHODE-RAY TUBE

Oscilloscope tube with flat face, side connections to the deflector plates. The high sensitivities of this mesh tube render it suitable for transistorized equipment. The phosphor screen is metal backed.

QUICK REFERENCE DATA

Final accelerator voltage	$V_{g_9(\ell)}$	15	kV
Display area		6x10	cm
Deflection coefficient, horizontal	M_x	9.5	V/cm
vertical	M_y	= 2.9	V/cm

SCREEN

	Colour	Persistence
D13-26GH	green	medium short
D13-26GP	bluish green	medium short

Useful screen diameter min. 114 mm

Useful scan at $V_{g_9(\ell)}/V_{g_4} = 10$

horizontal min. 100 mm

vertical min. 60 mm

Spot eccentricity in horizontal direction ± 8 mm

Spot eccentricity in vertical direction ± 6 mm

HEATING

Indirect by A. C. or D. C.; parallel supply

Heater voltage $V_f = 6.3$ V

Heater current $I_f = 300$ mA

MECHANICAL DATA

Dimensions in mm

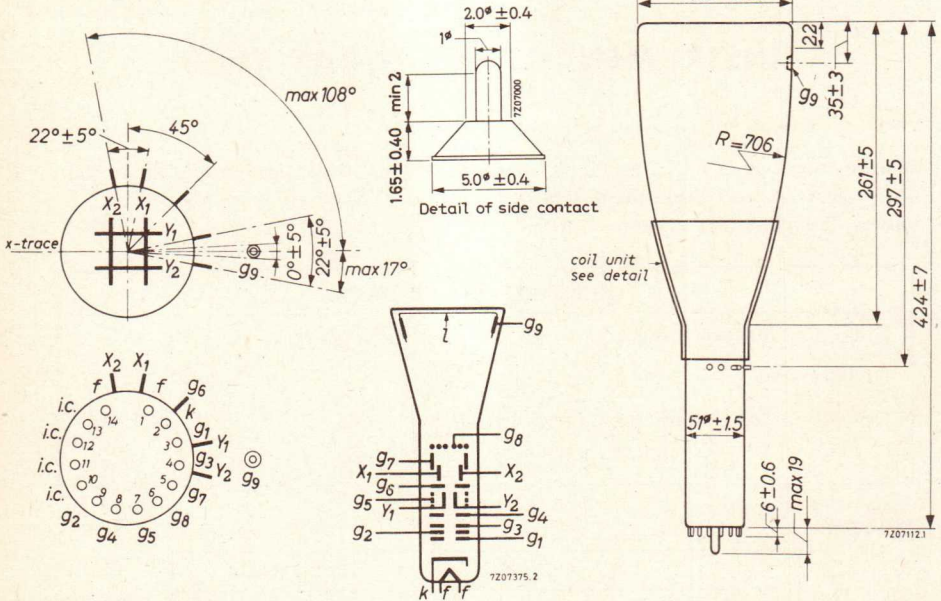

Mounting position: any

The tube should not be supported by the base alone and under no circumstances should the socket be allowed to support the tube.

Base

14 pin all-glass

Dimensions and connections

Overall length max. 450 mm

Face diameter max. 134.5 mm

Net weight

approx. 925 g

Accessories

Socket type 55566

Final accelerator contact connector type 55563A

Side contact connector type 55561

Mu-metal shield type 55555¹⁾

¹⁾ See page 6.

CAPACITANCES

x_1 to all other elements except x_2	$C_{x_1(x_2)}$	=	4.5	pF
x_2 to all other elements except x_1	$C_{x_2(x_1)}$	=	4.5	pF
y_1 to all other elements except y_2	$C_{y_1(y_2)}$	=	3.8	pF
y_2 to all other elements except y_1	$C_{y_2(y_1)}$	=	3.8	pF
x_1 to x_2	$C_{x_1x_2}$	=	2.7	pF
y_1 to y_2	$C_{y_1y_2}$	=	1.8	pF
Control grid to all other elements	C_{g1}	=	5.5	pF
Cathode to all other elements	C_k	=	3.0	pF

FOCUSING electrostatic

DEFLECTION double electrostatic

 x plates symmetrical
 y plates symmetrical

If use is made of the full deflection capabilities of the tube the deflection plates will intercept part of the electron beam; hence a low impedance deflection plate drive is desirable.

 Angle between x and y traces 90° See "Correction coils"

LINE WIDTH

Measured with the shrinking raster method in the centre of the screen

Final accelerator voltage	$V_{g_0(l)}$	=	15 000	15 000	V
Astigmatism control electrode voltage	V_{g_4}	=	2 400	1 500	V ⁴⁾
First accelerator voltage	V_{g_2}	=	2 400	1 500	V
Beam current	$I(l)$	=	10	10	μA
Line width	l.w.	=	0.3	0.4	mm

⁴⁾ See page 6

TYPICAL OPERATING CONDITIONS

Final accelerator voltage	$V_{g9(l)}$	=	15 000	V
Post deflection shield voltage (with respect to V_{g7})	V_{g8}	=	-12 to -18	V
Geometry control electrode voltage	V_{g7}	=	1500 ± 70	V ²⁾
Interplate shield voltage	V_{g6}	=	1500	V
Deflection plate shield voltage	V_{g5}	=	1500	V ³⁾
Astigmatism control electrode voltage	V_{g4}	=	1500 ± 70	V ⁴⁾
Focusing electrode voltage	V_{g3}	=	375 to 625	V
First accelerator voltage	V_{g2}	=	1500	V
Control grid voltage for visual extinction of focused spot	$-V_{g1}$	=	40 to 90	V
Deflection coefficient				
horizontal	M_x	=	8 to 11	V/cm
vertical	M_y	=	2.3 to 3.5	V/cm
Deviation of linearity of deflection		=	max. 2	% ⁵⁾
Geometry distortion			See note 6	
Useful scan				
horizontal		=	min. 100	mm
vertical		=	min. 60	mm

CIRCUIT DESIGN VALUES

Focusing voltage	V_{g3}	=	250 to 417	V per kV of V_{g4}
Control grid voltage for visual extinction of focused spot	$-V_{g1}$	=	30 to 56.7	V per kV of V_{g2}
Deflection coefficient at $V_{g9(l)}/V_{g4} = 10$				
horizontal	M_x	=	6.3 to 8.4	V/cm per kV of V_{g4}
vertical	M_y	=	1.53 to 2.33	V/cm per kV of V_{g4}
Control grid circuit resistance	R_{g1}	=	max. 1	M Ω
Deflection plate circuit resistance	R_x, R_y	=	max. 50	k Ω
Focusing electrode current at a beam current of max. 25 μ A	I_{g3}	=	-25 to +25	μ A ⁷⁾

2)3)4)5)6)7) See page 6.

LIMITING VALUES (Absolute max. rating system)

Final accelerator voltage	$V_{g9(\ell)}$	= max. 16500 V
		= min. 9000 V
Post deflection shield voltage	V_{g8}	= max. 2500 V
		= min. 1350 V
Geometry control electrode voltage	V_{g7}	= max. 2500 V
		= min. 1350 V
Interplate shield voltage	V_{g6}	= max. 2500 V
		= min. 1350 V
Deflection plate shield voltage	V_{g5}	= max. 2500 V
		= min. 1350 V
Astigmatism control electrode voltage	V_{g4}	= max. 2500 V
		= min. 1350 V
Focusing electrode voltage	V_{g3}	= max. 2500 V
First accelerator voltage	V_{g2}	= max. 2500 V
		= min. 1350 V
Control grid voltage		
negative	$-V_{g1}$	= max. 200 V
positive	V_{g1}	= max. 0 V
Voltage between astigmatism electrode and any deflection plate	$V_{g4/x}$ $V_{g4/y}$	= max. 500 V = max. 500 V
Cathode to heater voltage		
cathode positive	$V_{+k/f-}$	= max. 200 V
cathode negative	$V_{-k/f+}$	= max. 125 V
Screen dissipation	W_{ℓ}	= max. 3 mW/cm ²
Ratio $V_{g9(\ell)}/V_{g4}$	$V_{g9(\ell)}/V_{g4}$	= max. 10
Cathode current, average	I_k	= max. 300 μ A

- 1) To avoid damaging the side contacts the narrower end of the mu-metal shield should have an internal diameter of not less than 70 mm.
- 2) This tube is designed for optimum performance when operating at the ratio $V_{g9(l)}/V_{g4} = 10$. Operation at other ratio may result in changes in deflection uniformity and geometry distortion. The geometry control electrode voltage should be adjusted for optimum performance. For any necessary adjustment its potential will be within the stated range.
- 3) This voltage should be equal to the mean x- and y plates potential.
- 4) The astigmatism control electrode voltage should be adjusted for optimum spot shape. For any necessary adjustment its potential will be within the stated range.
- 5) The sensitivity at a deflection of less than 75% of the useful scan will not differ from the sensitivity at a deflection of 25% of the useful scan by more than the indicated value.
- 6) A graticule, consisting of concentric rectangles of 100 mm x 60 mm and 98 mm x 58.2 mm is aligned with the electrical x axis of the tube. The edges of a raster will fall between these rectangles with optimum correction potentials applied.
- 7) Values to be taken into account for the calculation of the focus potentiometer.

CORRECTION COILS

The D13-26.. is provided with a coil unit consisting of a pair of coils for:

- Correction of the orthogonality of the x and y traces (which means that at the centre of the screen the angle between the x and y traces can be made exactly 90°).
- Vertical shift of the scanned area.

DETAIL DRAWING OF COIL UNIT

Dimensions in mm

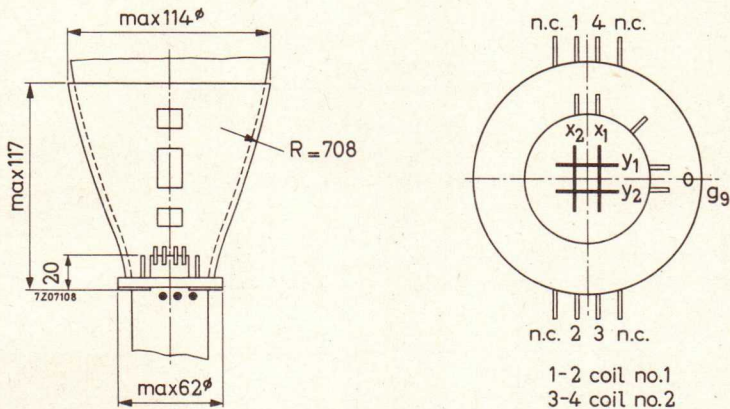

The currents required under typical operating conditions, the tube being screened by a mu-metal shield closely surrounding the coils (e.g. 55555), are max. 7 mA per degree of angle correction and max. 4 mA per mm of shift. If no such shield is used these values have to be multiplied by a factor k ($1 < k < 2$), the value of which depends on the diameter of the shield and approaches 2 for the case no shield is present.

The D.C. resistance is approx. 180 Ω per coil.

When designing the supply circuit for these coils it should be considered that the maximum current required in either coil can be 34 mA.

Circuit diagrams

A suitable circuit permitting independent control of orthogonality correction and vertical shift is given in Fig. 1.

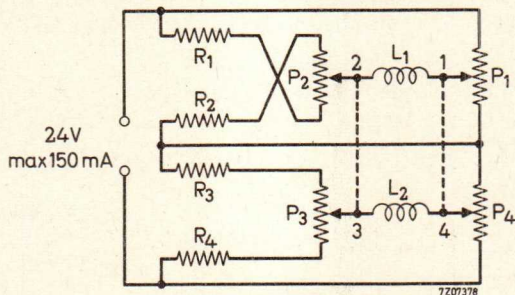

- P1, P4 : Potentiometers 220 Ω , 3 W, ganged
- P2, P3 : Potentiometers 150 Ω , 2 W, ganged
- R1, R2, R3, R4: Resistors 33 Ω , 0,5 W

Fig. 1

The dissipation in the potentiometers can be reduced considerably if the requirement of independent control is dropped (see Fig. 2).

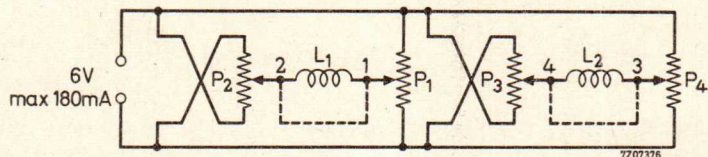

- P1, P2 : Potentiometers 220 Ω , 1 W, ganged
- P3, P4 : Potentiometers 220 Ω , 1 W, ganged

Fig. 2

A further reduction of the dissipation can be obtained by inserting a commutator for each coil (see fig. 3).

The procedure of adjustment will then become more complicated, but it should be kept in mind that a readjustment is necessary only when the tube has to be replaced.

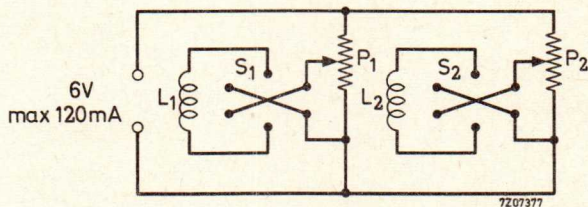

P_1, P_2 : Potentiometers, 500Ω , 0,5 Watt
 S_1, S_2 : Commutators

Fig. 3

For the adjustment of the currents the following procedure is recommended:

- a. With the tube fully scanned in the vertical direction the scanned area must be shifted so that the useful vertical scan on either side of the geometric centre of the screen meets the published value of 30 mm min.
 With the circuit according to fig. 1 this is done by means of the ganged potentiometers P_1 and P_4 .
- b. Adjustment of orthogonality by means of the ganged potentiometers P_2 and P_3 in fig. 1. A slight readjustment of P_1 and P_4 may be necessary afterwards.

With a circuit according to fig. 2 or 3 these corrections have to be performed by means of successive adjustments of the currents in the coils.

The most convenient deflection signal is a square waveform permitting an easy and fairly accurate check of orthogonality.

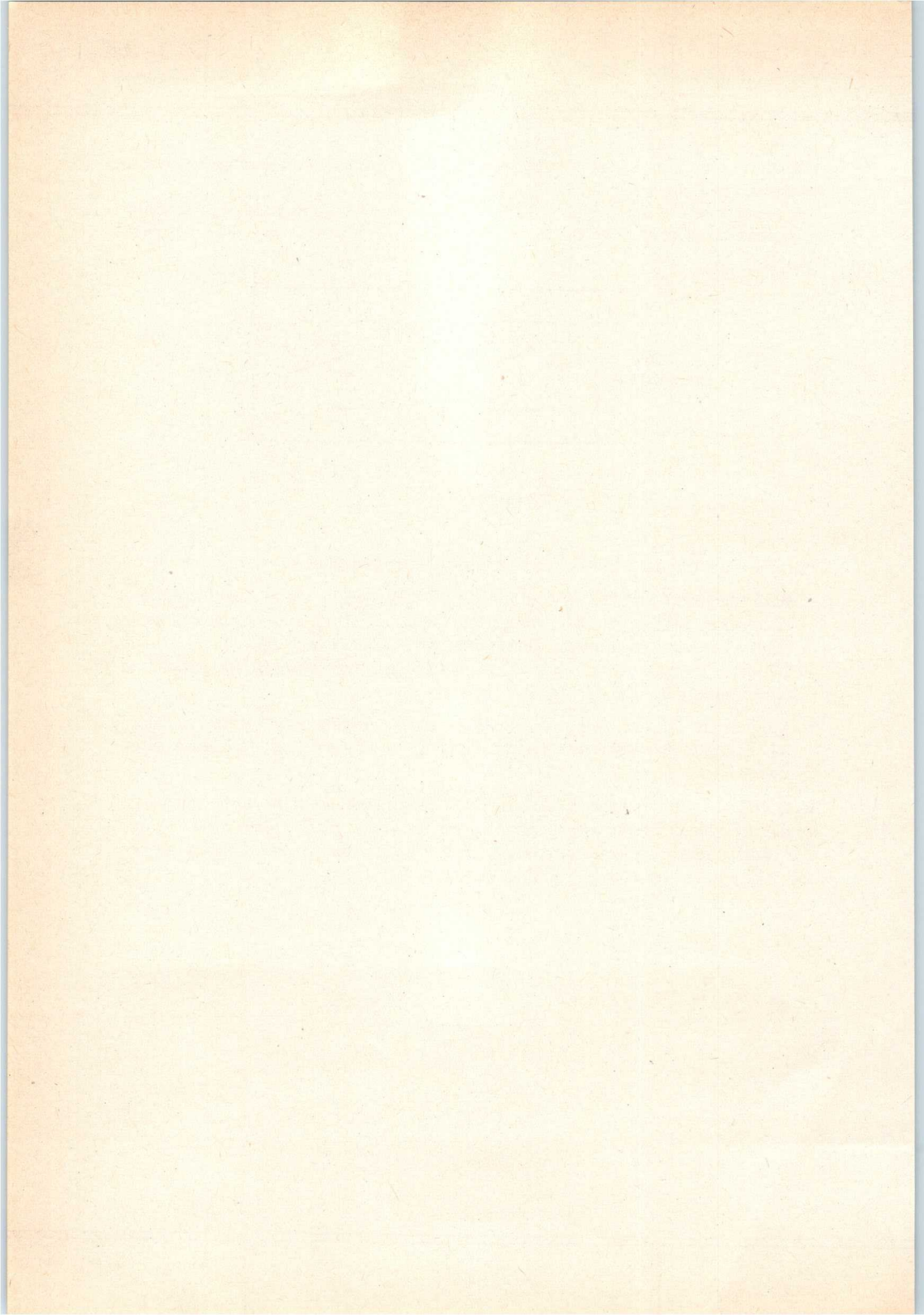

INSTRUMENT CATHODE-RAY TUBE

The D13-26../01 is equivalent to the D13-26.. but features an integral graticule. This graticule can be illuminated.

MECHANICAL DATA

Dimensions in mm

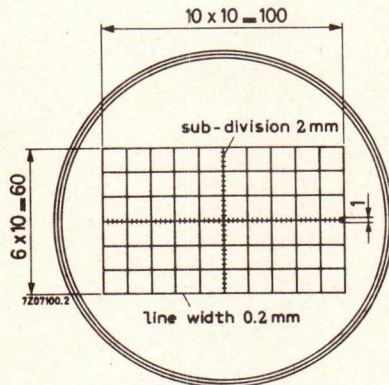
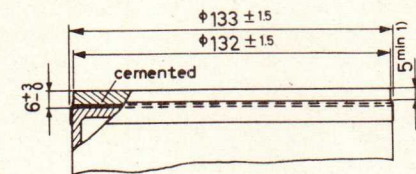

Maximum angle between x-trace and x-axis of the graticule $\pm 5^\circ$

¹⁾ Clear area for light conductor.

ALIGNMENT

In order to align the x-trace and the x-axis of the graticule an image rotating coil may be used. This coil should be positioned at one third of the cone length, seen from the face end, and can be attached to the inner surface of the mu-metal shield. Under typical operating conditions maximum 90 ampere-turns are required for alignment.

ILLUMINATION OF THE GRATICULE

To illuminate the internal graticule a light conductor (e.g. of perspex) should be used. In order to achieve the most efficient light conductance, the holes for the lamps and the edge adjacent to the tube should be polished, and the distance between the perspex plate and the tube should be as small as possible. It is advisable to apply reflective material to the outer circumference and, if possible, also to the upper and lower faces of the light conductor. The thickness of the conductor should not exceed 3 mm, and its position relative to the frontplate of the tube should be adjusted for optimum illumination of the graticule lines.

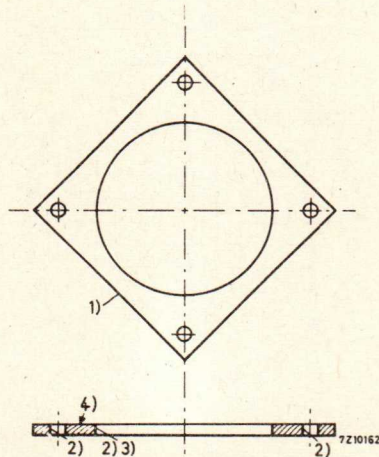

- 1) Reflective material.
- 2) Polished.
- 3) Close and constant distance to front plate of tube.

It is essential that the light conductor and the front plate of the tube are in plane.

- 4) If possible reflective material.

INSTRUMENT CATHODE-RAY TUBE

13 cm diameter flat faced short oscilloscope tube (max. 35 cm) with post-deflection acceleration by means of a helical electrode. The tube is provided with deflection blanking.

QUICK REFERENCE DATA

Final accelerator voltage	$V_{g7(\ell)} = 3000 \text{ V}$
Display area	8 cm x full scan
Deflection coefficient, horizontal	$M_x = 24 \text{ V/cm}$
vertical	$M_y = 11.5 \text{ V/cm}$

SCREEN

	Colour	Persistence
D13-27GH	green	medium short

Useful screen diameter min. 114 mm

Useful scan at $V_{g7(\ell)}/V_{g5} = 2$

horizontal full scan

vertical min. 80 mm

The useful scan may be shifted vertically to a max. of 4 mm with respect to the geometric centre of the faceplate.

HEATING

Indirect by A.C. or D.C.; parallel supply

Heater voltage

$$V_f = 6.3 \text{ V}$$

Heater current

$$I_f = 300 \text{ mA}$$

→ MECHANICAL DATA

Dimensions in mm

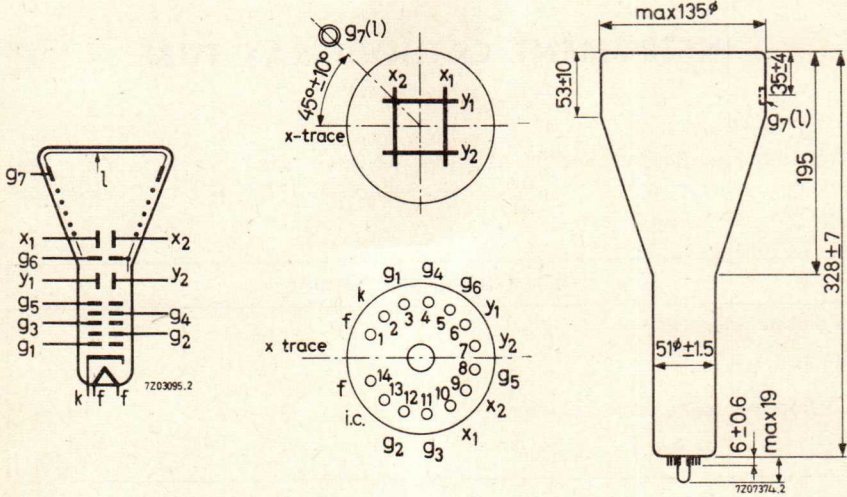

Mounting position: any

The tube should not be supported by the base alone and under no circumstances should the socket be allowed to support the tube.

Base 14 pin all glass

Dimensions and connections

Overall length (also with socket type 55566) max. 354 mm

Face diameter max. 135 mm

Net weight approx. 680 g

Accessories

Socket (supplied with tube) type 55566

Final accelerator contact connector type 55563A

Mu metal shield type 55557

CAPACITANCES

x_1 to all other elements except x_2	$C_{x_1(x_2)} = 4.5 \text{ pF}$
x_2 to all other elements except x_1	$C_{x_2(x_1)} = 4.5 \text{ pF}$
y_1 to all other elements except y_2	$C_{y_1(y_2)} = 5 \text{ pF}$
y_2 to all other elements except y_1	$C_{y_2(y_1)} = 5.5 \text{ pF}$
x_1 to x_2	$C_{x_1x_2} = 2.5 \text{ pF}$
y_1 to y_2	$C_{y_1y_2} = 1.2 \text{ pF}$
Grid No.1 to all other elements	$C_{g_1} = 5.5 \text{ pF}$
Cathode to all other elements	$C_k = 5 \text{ pF}$
Grid No.3 to all other elements	$C_{g_3} = 10 \text{ pF}$

FOCUSING electrostatic

DEFLECTION double electrostatic

x plates symmetrical

y plates symmetrical

If use is made of the full deflection capabilities of the tube the deflection plates will intercept part of the electron beam; hence a low impedance deflection plate drive is desirable.

Angle between x and y traces $90^\circ \pm 1^\circ$

LINE WIDTH

Measured with the shrinking raster method in the centre of the screen.

Final accelerator voltage	$V_{g_7(\ell)} = 3000 \text{ V}$
Astigmatism control electrode voltage	$V_{g_5} = 1500 \text{ V}^2$
First accelerator voltage	$V_{g_2} = 1500 \text{ V}$
Beam current	$I_{g_7(\ell)} = 10 \text{ } \mu\text{A}$
Line width	l.w. = 0.25 mm

HELIX

Post deflection accelerator helix resistance min. 50 M Ω
 The helix is connected between $g_7(\ell)$ and g_6

2) See page 5

TYPICAL OPERATING CONDITIONS

Final accelerator voltage	$V_{g7(\ell)} =$	3000 V
Geometry control electrode voltage	$V_{g6} =$	$1500 \pm 75 \text{ V}^1)$
Astigmatism control electrode voltage	$V_{g5} =$	$1500 \pm 75 \text{ V}^2)$
Focusing electrode voltage	$V_{g4} =$	300 to 550 V
Deflection blanking electrode voltage	$V_{g3} =$	1500 V
Deflection blanking control voltage	$\Delta V_{g3} =$	max. -60 $\text{V}^3)$
First accelerator voltage	$V_{g2} =$	1500 V
Control grid voltage for visual extinction of focused spot	$V_{g1} =$	-38 to -135 V
Deflection coefficient		
horizontal	$M_x =$	21 to 27 V/cm
vertical	$M_y =$	9.8 to 12.2 V/cm
Deviation of linearity of deflection		= max. 2 % ⁴⁾
Geometry distortion		See note 5
Useful scan		
horizontal		full scan
vertical		= min. 80 mm

CIRCUIT DESIGN VALUES

Focusing voltage	$V_{g4} =$	200 to 370 V per kV of V_{g5}
Control grid voltage for visual extinction of focused spot	$-V_{g1} =$	25 to 90 V per kV of V_{g2}
Deflection coefficient at		
$V_{g7(\ell)}/V_{g5} = 2$		
horizontal	$M_x =$	14 to 18 V/cm per kV of V_{g5}
vertical	$M_y =$	6.5 to 8.2 V/cm per kV of V_{g5}
Control grid circuit resistance	$R_{g1} =$	max. 1.5 $\text{M}\Omega$
Deflection plate circuit		
resistance	$R_x, R_y =$	max. 50 $\text{k}\Omega$
Focusing electrode current	$I_{g4} =$	-15 to +10 μA ⁶⁾

Notes see page 5

LIMITING VALUES (Absolute max. rating system)

Final accelerator voltage	$V_{g7(\ell)}$	= max. 3300 V
		= min. 1800 V
Geometry control electrode voltage	V_{g6}	= max. 1700 V
Astigmatism control electrode voltage	V_{g5}	= max. 1700 V
		= min. 1200 V
Focusing electrode voltage	V_{g4}	= max. 1200 V
Deflection blanking electrode voltage	V_{g3}	= max. 1700 V
First accelerator voltage	V_{g2}	= max. 1700 V
Control grid voltage		
negative	$-V_{g1}$	= max. 200 V
positive	$-V_{g1}$	= min. 0 V
Voltage between astigmatism control electrode and any deflection plate	$V_{g5/x}$	= max. 500 V
	$V_{g5/y}$	= max. 500 V
Screen dissipation	W_{ℓ}	= max. 3 mW/cm ²
Ratio $V_{g7(\ell)}/V_{g5}$	$V_{g7(\ell)}/V_{g5}$	= max. 2
Cathode current, average	I_k	= max. 300 μ A

- 1) This tube is designed for optimum performance when operating at the ratio $V_{g7(\ell)}/V_{g5} = 2$. Operation at other ratio may result in changes in deflection uniformity and geometry distortion. The geometry control electrode voltage should be adjusted for optimum performance. For any necessary adjustment its potential will be within the stated range.
- 2) The astigmatism control electrode voltage should be adjusted for optimum spot shape. For any necessary adjustment its potential will be within the stated range.
- 3) For beam blanking of a beam current of 10 μ A.
- 4) The sensitivity at a deflection of less than 75% of the usefull scan will not differ from the sensitivity at a deflection of 25% of the useful scan by more than the indicated value.
- 5) A graticule, consisting of concentric rectangles of 100 mm x 60 mm and 97 mm x 58 mm is aligned with the electrical x axis of the tube. The edges of a raster will fall between these rectangles with optimum correction potentials applied.
- 6) Values to be taken into account for the calculation of the focus potentiometer.

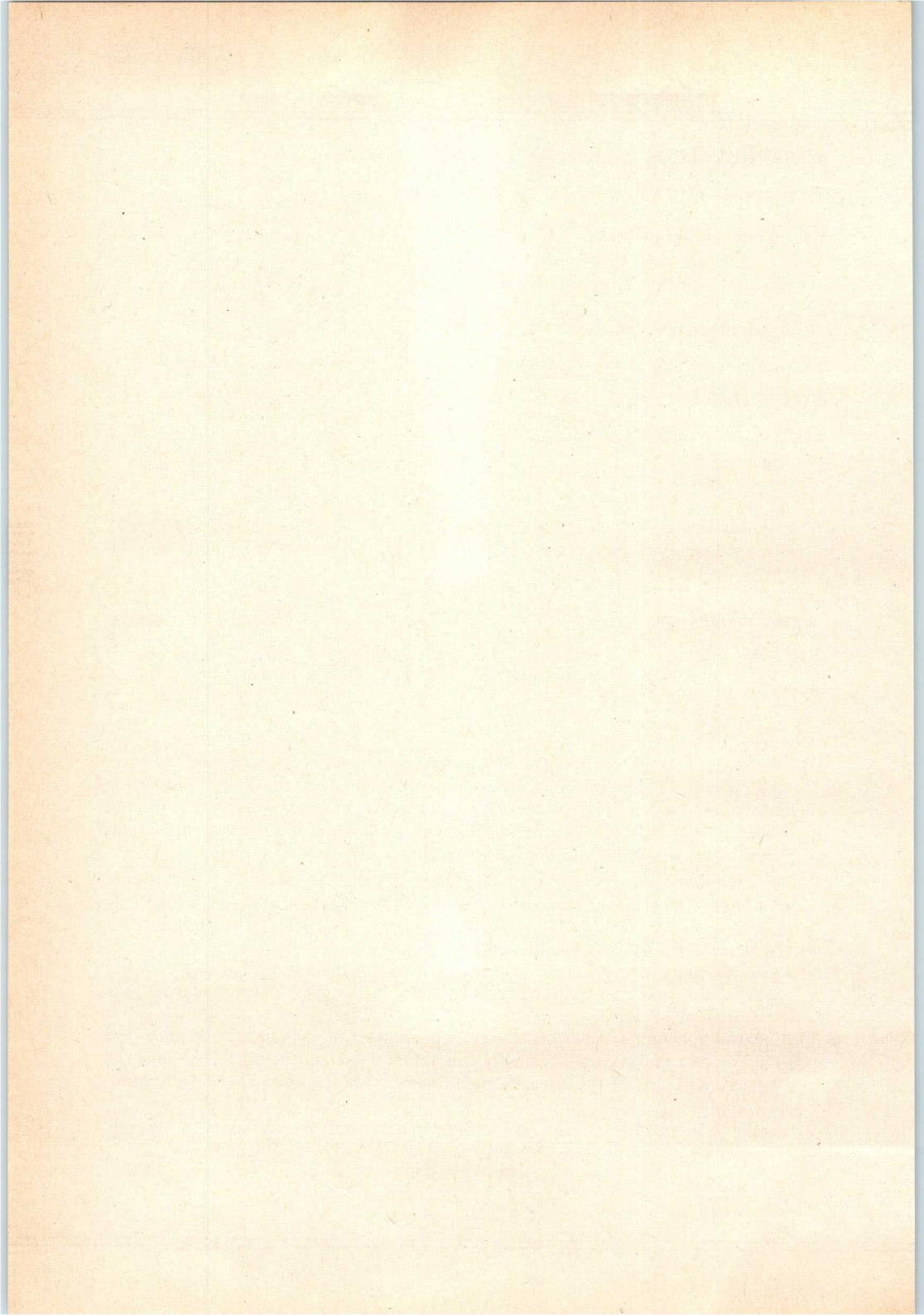

INSTRUMENT CATHODE-RAY TUBE

Oscilloscope tube with rectangular 13 cm diagonal flat face and metal-backed screen, provided with internal graticule. The high sensitivities of this mesh tube, together with the sectioned y-deflection plates, render the tube suitable for transistorized oscilloscopes for frequencies up to 100-250 MHz.

QUICK REFERENCE DATA

Final accelerator voltage	$V_{g9(\ell)}$	15	kV
Display area		100 x 60	mm^2
Deflection coefficient, horizontal vertical	M_x	9, 9	V/cm
	M_y	3	V/cm

SCREEN

	colour	persistence
D13-451GH/45	green	medium short

Useful screen area	min.	100 x 60	mm^2
Useful scan at $V_{g9(\ell)}/V_{g4} = 10$,	horizontal	min.	100 mm
	vertical	min.	60 mm
	Spot eccentricity in horizontal direction		± 8
Spot eccentricity in vertical direction		± 6	mm

The scanned raster can be shifted in vertical direction and aligned with the internal graticule by means of correction coils mounted on the tube (see page 6).
For illumination of the internal graticule see page 8.

HEATING : indirect by a.c. or d.c. ; parallel supply

Heater voltage	V_f	6, 3	V
Heater current	I_f	300	mA

MECHANICAL DATA

Dimensions in mm

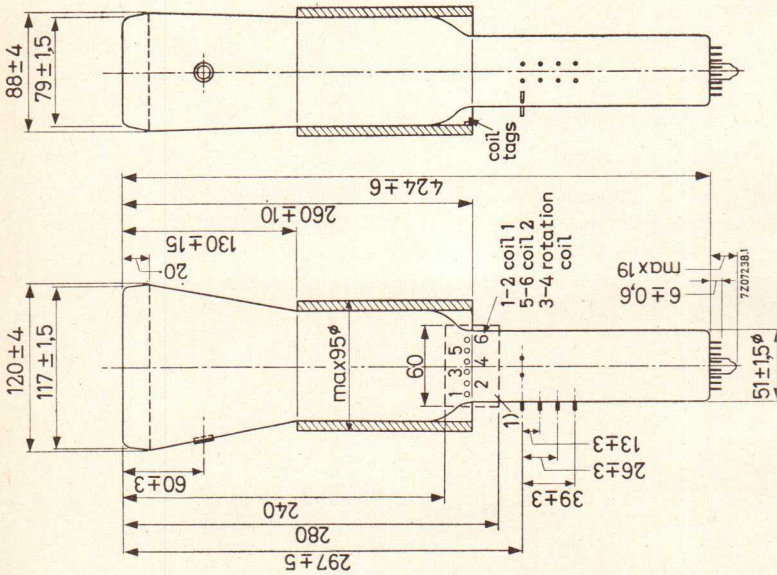
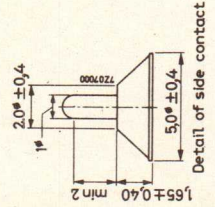
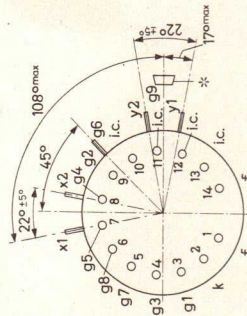
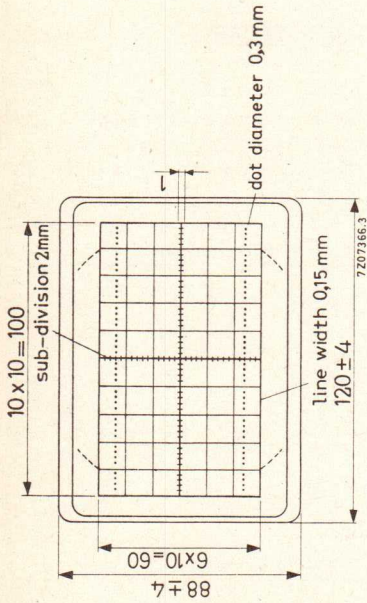

* The centre of the contact is located within a square of 10 mm x 10 mm around the true geometrical position.

MECHANICAL DATA (continued)Mounting position: any

The tube should not be supported by the base alone and under no circumstances should the socket be allowed to support the tube.

Dimensions and connections

See also outline drawing

Overall length (socket inclusive)	max.	449	mm
Face dimensions	max.	124 x 92	mm ²
<u>Net weight</u>	approx.	1100	g
<u>Base</u>		14-pin all glass	

Accessories

Socket	type	55566
Final accelerator contact connector	type	55563A
Side-contact connector	type	55561
Mu-metal screen	type	55568

CAPACITANCES

x_1 to all other elements except x_2	$C_{x_1(x_2)}$	4,8	pF
x_2 to all other elements except x_1	$C_{x_2(x_1)}$	4,8	pF
$y_{1.1}$ to all other elements except $y_{2.1}$	$C_{y_{1.1}(y_{2.1})}$	1,2	pF
x_1 to x_2	$C_{x_1x_2}$	2,5	pF
$y_{1.1}$ to $y_{2.1}$	$C_{y_{1.1}y_{2.1}}$	0,8	pF
Control grid to all other elements	C_{g_1}	6	pF
Cathode to all other elements	C_k	5	pF

FOCUSING electrostatic**DEFLECTION** double electrostatic

x plates symmetrical

y plates symmetrical

If is made of the full deflection capabilities of the tube the deflection plates will intercept part of the electron beam; hence a low impedance deflection plate drive is desirable.

Angle between x and y traces 90° (see "Correction Coils")

LINE WIDTH

Measured with the shrinking raster method in the centre of the screen under typical operating conditions, adjusted for optimum spot size at a beam current $I_{\ell} = 10 \mu\text{A}$

Line width	l. w.	0, 40	mm
------------	-------	-------	----

TYPICAL OPERATING CONDITIONS

Final accelerator voltage	$V_{g9(\ell)}$	15	kV
Post deflection shield voltage (mesh) w. r. t. V_{g7}	$V_{g8/g7}$	-12 to -18	V
Geometry control electrode voltage	V_{g7}	1500 ± 70	V ¹⁾
Interplate shield voltage	V_{g6}	1500	V ²⁾
Deflection plate shield voltage	V_{g5}	1500	V ²⁾
Astigmatism control electrode voltage	V_{g4}	1500 ± 50	V ³⁾
Focusing electrode voltage	V_{g3}	400 to 550	V
First accelerator voltage	V_{g2}	1500	V
Control grid voltage for visual extinction of focused raster	V_{g1}	-40 to -100	V
Deflection coefficient, horizontal	M_x	9, 9	V/cm
		max. 11	V/cm
vertical	M_y	3	V/cm
		max. 3, 3	V/cm
Deviation of linearity of deflection		max. 2	% ⁴⁾
Geometry distortion		see note 5	
Useful scan, horizontal		100	mm
		vertical	60

¹⁾ This tube is designed for optimum performance when operating at the ratio $V_{g9(\ell)}/V_{g4} = 10$. Operation at other ratio may result in changes in deflection uniformity and geometry distortion. The geometry control electrode voltage should be adjusted for optimum performance. For any necessary adjustment its potential will be within the stated range.

²⁾ This voltage should be equal to the mean x- and y plates potential.

³⁾ The astigmatism control electrode voltage should be adjusted for optimum spot shape. for any necessary adjustment its potential will be within the stated range.

⁴⁾ The sensitivity at a deflection of less than 75 % of the useful scan will not differ from the sensitivity at a deflection of 25 % of the useful scan by more than the indicated value.

⁵⁾ A graticule, consisting of concentric rectangles of 100 mm x 60 mm and 98 mm x 58, 2 mm is aligned with the electrical x axis of the tube.

With optimum correction potentials applied the edges of a raster will fall between these rectangles.

LIMITING VALUES (Absolute max. rating system)

Final accelerator voltage	$V_{g9(\ell)}$	max.	16,5	kV
		min.	9	kV
Post deflection shield voltage	V_{g8}	max.	2400	V
Geometry control electrode voltage	V_{g7}	max.	2400	V
		min.	1350	V
Interplate shield voltage	V_{g6}	max.	2400	V
		min.	1350	V
Deflection plate shield voltage	V_{g5}	max.	2400	V
		min.	1350	V
Astigmatism control electrode voltage	V_{g4}	max.	2400	V
		min.	1350	V
Focusing electrode voltage	V_{g3}	max.	2400	V
First accelerator voltage	V_{g2}	max.	1800	V
		min.	1350	V
Control grid voltage, negative	$-V_{g1}$	max.	200	V
		positive	V_{g1}	max.
Cathode to heater voltage, cathode positive	V_{kf}	max.	200	V
		cathode negative	$-V_{kf}$	max.
Voltage between astigmatism control electrode and any deflection plate	$V_{g4/x}$	max.	500	V
		$V_{g4/y}$	max.	500
Screen dissipation	W_{ℓ}	max.	8	mW/cm ²
Ratio $V_{g9(\ell)}/V_{g4}$	$V_{g9(\ell)}/V_{g4}$	max.	10	
Average cathode current	I_k	max.	300	μA

CORRECTION COILS

The D13-451../45 is provided with a coil unit consisting of:

1. a pair of coils for
 - a. correction of the orthogonality of the x and y traces (which means that the angle between the x and y traces at the centre of the screen can be made exactly 90°).
 - b. vertical shift of the scanned area.
2. a single coil for image rotation (aligning the x trace with the x lines of the graticule).

Orthogonality and shift

The currents required under typical operating conditions are max. 4 mA per degree of angle correction and max. 2 mA per millimeter of shift; the maximum required current for both purposes taken together does not exceed 18 mA.

These values apply to a tube operating with a mu-metal shield closely surrounding the coils.

If no such shield is used they have to be multiplied by a factor $K(1 < K < 2)$ the value of which depends on the dimensions of the shield and approaches 2 for the case no shield is present.

The d.c. resistance of the coil is approx. 220 Ω .

Image rotation

The image rotation coil is concentrically wound. Under typical operating conditions a current of max. 45 mA will be required for complete correction. The d.c. resistance of this coil is approx. 550 Ω .

Circuit diagrams

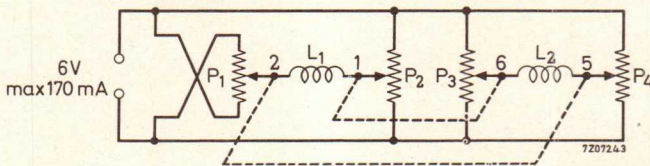

Fig. 1

P_1, P_2 potentiometers 220 Ω , 1 watt; ganged
 P_2, P_3 potentiometers 220 Ω , 1 watt; ganged

With the above circuit almost independent control for shift and angle correction is achieved. This facilitates the correct adjustment to a great extent. The dissipation of the potentiometers can be reduced considerably if the requirement of independent controls is dropped (see Fig. 2).

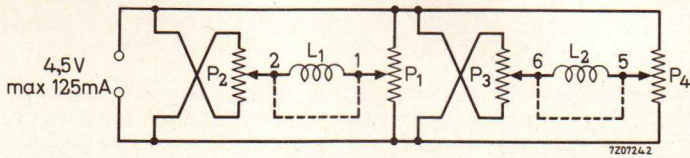

Fig. 2

P₁, P₂ potentiometers 220 Ω, 1 watt; ganged
 P₃, P₄ potentiometers 220 Ω, 1 watt; ganged

A further reduction of dissipation can be obtained by providing a commutator for each coil (see circuit Fig. 3).

The procedure of adjustment will then become more complicated but it should be kept in mind that a readjustment is necessary only when the tube has to be replaced.

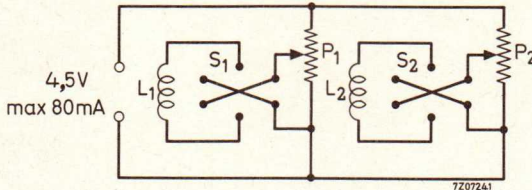

Fig. 3

P₁, P₂ potentiometers 220 Ω, 1 watt
 S₁, S₂ commutators

A suitable circuit for the image rotating coil is given in Fig. 4.

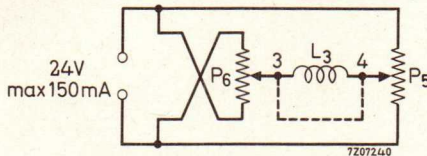

Fig. 4

P₅, P₆ potentiometers 500 Ω, 3 watt; ganged

The following procedure of adjustment is recommended:

- a. Align the x trace with the graticule by means of the image rotating coil.
- b. With the tube fully scanned in the vertical direction, the image has to be shifted so that the graticule is fully covered. With the circuit according to Fig. 1 this is done by means of the ganged potentiometers P₁ and P₄.
- c. Adjustment of orthogonality by means of the ganged potentiometers P₂ and P₃. A slight readjustment of P₁ and P₄ may be necessary afterwards.
- d. Readjustment of the image rotation if necessary.

With a circuit according to Fig. 2 or 3 these corrections have to be performed by means of successive adjustments of the currents in the coils.

The most convenient deflection signal is a square wave form permitting an easy and fairly accurate visual check of orthogonality.

ILLUMINATION OF THE GRATICULE

To illuminate the internal graticule a light conductor (e. g. of perspex) should be used. In order to achieve the most efficient light conductance, the holes for the lamps and the edge adjacent to the tube should be polished, and the distance between the perspex plate and the tube should be as small as possible. It is advisable to apply reflective material to the outer circumference and, if possible, also to the upper and lower faces of the light conductor. The thickness of the conductor should not exceed 3 mm, and its position relative to the faceplate of the tube should be adjusted for optimum illumination of the graticule lines.

INSTRUMENT CATHODE-RAY TUBE

13 cm diameter flat faced monoaccelerator oscilloscope tube primarily intended for use in inexpensive oscilloscopes and read-out devices.

QUICK REFERENCE DATA

Accelerator voltage	$V_{g2, g4, g5}(\ell)$	2000 V
Display area		100 x 80 mm ²
Deflection coefficient, horizontal	M_x	31.3 V/cm
vertical	M_y	14.4 V/cm

SCREEN

	colour	persistence
D13-480GH	green	medium short
D13-480GM	yellowish green	long

Useful screen diameter min. 114 mm

Useful scan

horizontal min. 100 mm

vertical min. 80 mm

The useful scan may be shifted vertically to a max. of 6 mm with respect to the geometric centre of the faceplate.

HEATING: Indirect by A.C. or D.C.; parallel supply

Heater voltage	V_f	6.3 V
Heater current	I_f	300 mA

MECHANICAL DATA (Dimensions in mm)

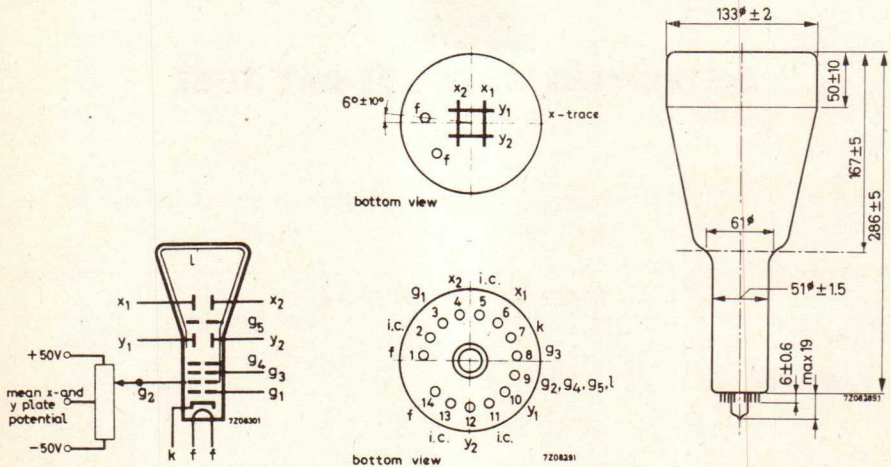

Mounting position: any

The tube should not be supported by the base alone and under no circumstances should the socket be allowed to support the tube.

Dimensions and connections

See also outline drawing

Overall length	max.	310	mm
Face diameter	max.	135	mm

Base 14 pin all glass

Net weight approx. 650 g

Accessories

Socket (supplied with tube)	type	55566
Mu-metal shield	type	55580

CAPACITANCES

x_1 to all other elements except x_2	$C_{x1(x2)}$	4	pF
x_2 to all other elements except x_1	$C_{x2(x1)}$	4	pF
y_1 to all other elements except y_2	$C_{y1(y2)}$	3.5	pF
y_2 to all other elements except y_1	$C_{y2(y1)}$	3	pF
x_1 to x_2	C_{x1x2}	1.6	pF
y_1 to y_2	C_{y1y2}	1.1	pF
Control grid to all other elements	C_{g1}	5.5	pF
Cathode to all other elements	C_k	4	pF

FOCUSING electrostatic**DEFLECTION** double electrostatic

x plates symmetrical

y plates symmetrical

If use is made of the full deflection capabilities of the tube the deflection plates will intercept part of the electron beam, hence a low impedance deflection plate drive is desirable.

Angle between x and y traces $90 \pm 1^\circ$

LINE WIDTH 3)

Measured with the shrinking raster method in the centre of the screen under typical operating conditions, adjusted for optimum spot size at a beam current $I_l = 10 \mu A$. 1)

Line width l.w. 0.30 mm

1) As the construction of this tube does not permit a direct measurement of the beam current, this current should be determined as follows:

a) under typical operating conditions, apply a small raster display (no overscan), adjust V_{g1} for a beam current of approx. $10 \mu A$ and adjust V_{g3} and $V_{g2, g4, g5, l}$ for optimum spot quality at the centre of the screen.

b) under these conditions, but no raster, the deflection plate voltages should be changed to

$V_{y1} = V_{y2} = 2000 V$; $V_{x1} = 1300 V$; $V_{x2} = 1700 V$, thus directing the total beam current to x_2 .

Measure the current on x_2 and adjust V_{g1} for $I_{x2} = 10 \mu A$ (being the beam current I_l)

c) set again for the conditions under a), without touching the V_{g1} control. Now a raster display with a true $10 \mu A$ screen current is achieved.

d) focus optimally in the centre of the screen (do not adjust the astigmatism control) and measure the line width.

3) See page 4

TYPICAL OPERATING CONDITIONS ³⁾

Accelerator voltage	$V_{g_2, g_4, g_5, \ell}$	2000 V
Astigmatism control voltage	$\Delta V_{g_2, g_4, g_5, \ell}$	± 50 V ¹⁾
Focusing electrode voltage	V_{g_3}	220 to 370 V
Control grid voltage for visual extinction of focused spot	V_{g_1}	max. -65 V
Grid drive for 10 μ A screen current		approx. 10 V
Deflection coefficient, horizontal	M_x	31.3 V/cm
		max. 33 V/cm
vertical	M_y	14.4 V/cm
		max. 15.5 V/cm
Deviation of linearity of deflection		max. 1 % ²⁾
Geometry distortion		see note 4
Useful scan, horizontal		min. 100 mm
		vertical

LIMITING VALUES (Absolute max. rating system)

Accelerator voltage	$V_{g_2, g_4, g_5, \ell}$	max. 2200 V
		min. 1500 V
Focusing electrode voltage	V_{g_3}	max. 2200 V
Control grid voltage, negative	$-V_{g_1}$	max. 200 V
		min. 0 V
Cathode to heater voltage	V_{kf} $-V_{kf}$	max. 125 V
		max. 125 V
Grid drive, average		max. 20 V
Screen dissipation	W_{ℓ}	max. 3 mW/cm ²

- 1) All that will be necessary when putting the tube into operation is to adjust the astigmatism control voltage once for optimum spot shape in the screen centre. The control voltage will always be in the range stated, provided the mean x and certainly the mean y plate potential was made equal to $V_{g_2, g_4, g_5, \ell}$ with zero astigmatism correction.
- 2) The sensitivity at a deflection of less than 75% of the useful scan will not differ from the sensitivity at a deflection of 25% of the useful scan by more than the indicated value.
- 3) The mean x and certainly the mean y plate potential should be equal to $V_{g_2, g_4, g_5, \ell}$ with astigmatism adjustment set to zero.
- 4) A graticule, consisting of concentric rectangles of 70 mm x 85 mm and 68.8 mm x 83 mm as aligned with the electrical x-axis of the tube. The edges of a raster will fall between these rectangles.

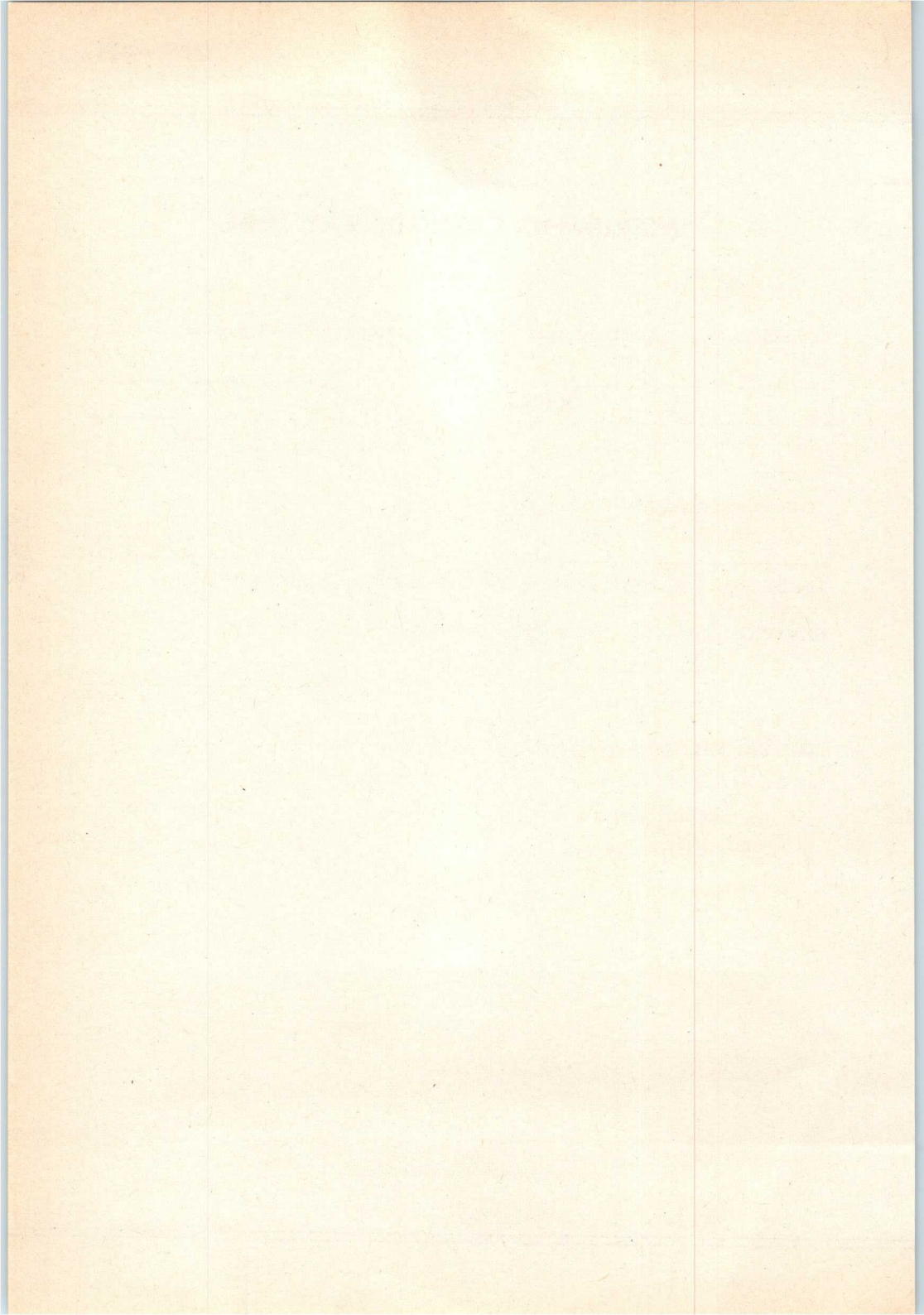

INSTRUMENT CATHODE-RAY TUBE

The D13-500GH/01 is a wide-band oscilloscope tube designed for observation and measurement of high frequency phenomena.

This tube has a rectangular 13 cm diagonal flat face with aluminized screen and internal graticule, post-deflection accelerator with mesh, vertical deflection by means of a symmetrical helix system, scan magnification in the vertical direction by means of an electrostatic quadrupole lens and correction coils for trace alignment, vertical shift of the display area and correction of the orthogonality of traces.

QUICK REFERENCE DATA

Final accelerator voltage	$V_{g13(\ell)}$	15 kV
Display area		100 x 60 mm ²
Deflection coefficient, horizontal vertical	M_x	13.5 V/cm
	M_y	1.7 V/cm
Bandwidth of the vertical deflection system	B	800 MHz

SCREEN

	colour	persistence
D13-500GH/01	green	medium short

Useful screen dimensions min. 100 x 60 mm²

Useful scan at $V_{g13(\ell)}/V_{g2} = 6$

horizontal	min.	100 mm
vertical	min.	60 mm

Eccentricity in horizontal direction max. 7 mm

Eccentricity in vertical direction max. 6 mm

The scanned raster can be shifted in vertical direction and aligned with the internal graticule by means of correction coils mounted on the tube (see page 14).

For illumination of the internal graticule see page 16.

DESCRIPTION

General

The D13-500GH/01 has been primarily designed for wide-band high-frequency applications. It combines high brightness, high deflection sensitivity and a large bandwidth of the vertical deflection system.

In order to obtain the high sensitivity, the post-deflection acceleration system embodies a mesh. The sensitivity in the vertical direction has been further increased by means of an electrostatic quadrupole lens that has been inserted between the vertical deflection system and the horizontal deflection plates. The large bandwidth has been obtained by using, for the vertical deflection, a delay-line system instead of deflection plates. With the typical operating conditions, 2500 V first accelerator voltage and 15000 V final accelerator voltage, the vertical and the horizontal deflection factors are about 2 V/cm and 15 V/cm respectively, with a $10 \times 6 \text{ cm}^2$ display area.

The bulb has a rectangular face and the screen is aluminized. To eliminate parallax errors, an internal graticule is incorporated. Correction coils have been provided to permit image rotation, correction of the orthogonality of traces and the adjustment of the vertical useful scan with respect to the graticule.

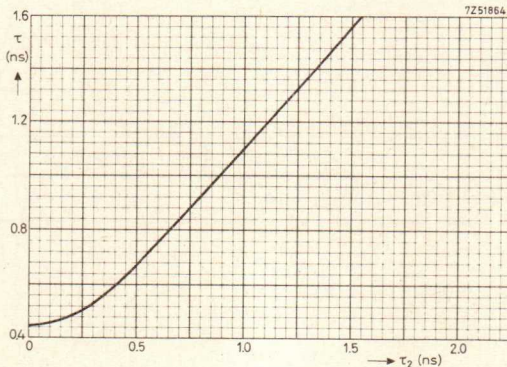

Fig. 1

Rise time of the display τ as a function of the rise time of the input signal τ_2

The vertical deflection system

For the vertical deflection, a delay-line system is used so that transit-time effects are practically eliminated. The system consists of two flattened helices to which a symmetrical deflection signal should be applied. Under these conditions, the characteristic impedance of each helix is 150Ω . The input and output terminals are brought out on opposite sides of the neck on the same plane. The input terminals are connected to the beginning of the helices by means of a matched, internal two-wire transmission line. The output of the deflection system should be properly terminated in order to avoid signal reflections.

With the typical operating conditions, the band-width of the deflection system, i.e. the frequency at which the sensitivity is 3 dB below its value at D.C., is about 800 MHz. Even above this frequency, the response decreases only gradually so that, for narrow-band applications, the tube can be used with reduced vertical sensitivity up to about 2000 MHz.

The rise time τ_1 , i.e. the time interval during which the display of an ideal step-function signal applied to the input goes from 10% to 90% of its final value, is about 0.45 ns. If the input signal has the rise-time τ_2 , the rise-time τ of the display is approximately given by

$$\tau = \sqrt{\tau_1^2 + \tau_2^2}$$

In Fig. 1, τ has been plotted as a function of τ_2 , with $\tau_1 = 0.45$ ns. If, for example, the tube is used in combination with an amplifier and the rise-time of the display is to be 1.4 ns (corresponding with 250 MHz band-width), the rise-time of the amplifier should be 1.33 ns. It can be seen that in this region the rise-time of the display is almost equal to the amplifier rise-time, without a significant contribution of the cathode-ray tube.

If the tube is to be used without an amplifier in order to make use of its full band-width capabilities, care should be taken to ensure good symmetry of the input signal.

Fig. 2 shows how the tube can be connected to a 50Ω coaxial input. A matched power divider is used which delivers two identical output signals. One of these is inverted by means of a pulse inverter. An additional length of 50Ω cable should be inserted into the path of the non-inverted signal having the same delay time as the pulse inverter so that the two signals arrive at the input of the deflection system at the same time. The 75Ω shunt resistors serve to obtain a correct termination of the 50Ω lines. Since each branch of the power divider has 6 dB attenuation, the sensitivity, measured at the 50Ω input, is also 2 V/cm.

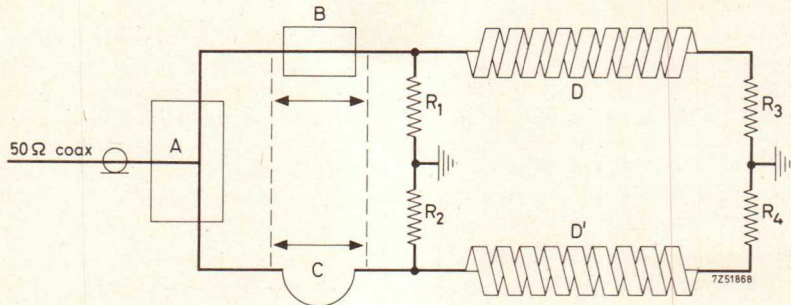

Fig. 2

Connection to an asymmetrical 50 Ω input

- | | |
|------------------|-------------------------------------|
| A: Power divider | R_1, R_2 : Resistors 75 Ω |
| B: Inverter | R_3, R_4 : Resistors 150 Ω |
| C: Cable | D, D': Deflection system |
- Note: Delay of inverter B and cable C are equal.

Scan magnifier and focusing system

As already mentioned, an electrostatic quadrupole lens, i.e. an electron lens which has two mutually perpendicular planes of symmetry, divergent in one plane and convergent in the other, is used for the magnification of the vertical deflection. This lens is inserted between the vertical deflection system and the horizontal deflection plates, with its plane of divergence in the direction of the vertical deflection. Therefore, it magnifies the vertical deflection without affecting the horizontal deflection.

Because of the astigmatic properties of this quadrupole lens, a conventional, rotationally symmetrical focusing lens cannot be used. Instead of this, two more electrostatic quadrupole lenses are incorporated so that focusing is accomplished by means of three quadrupole lenses, with alternating orientation of their planes of convergence and divergence. The focusing action is schematically shown in Fig. 3. The strength of the scan-magnifier lens is controlled by applying to the electrode g_1 a negative voltage with respect to g_2 . Within a certain range of this voltage, corresponding to a scan-magnification factor M_{sc} , i.e. the ratio of the deviations on the screen with and without scan magnification respectively, between 1.8 and 2 the combined effect of the three lenses will yield an approximately circular spot at moderate beam currents. (At high beam currents, when space-charge repulsion causes an increase of spot size, the width of the vertical lines will be smaller than that of the horizontal lines).

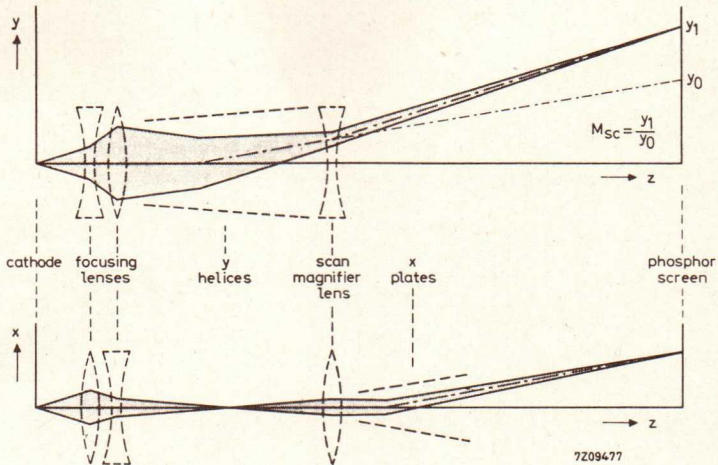

Fig.3

In this range, line-width at a fixed value of screen current, and screen current at a fixed value of grid No.1 voltage, are increasing functions of the scan-magnification factor. Figs.4 and 5 show the average relative change with respect to the values at $M_{sc} = 1.9$ which, generally, is the most suitable compromise.

For minimum defocusing of vertical lines near the upper and lower edge of the display area, the electrode g_3 should be kept at a positive voltage with respect to g_2 (about 200 V with 2500 V first accelerator voltage). As this voltage also has some effect on the scan-magnification factor, both g_3 and g_9 should be connected to g_2 when the deviation without scan magnification is being measured.

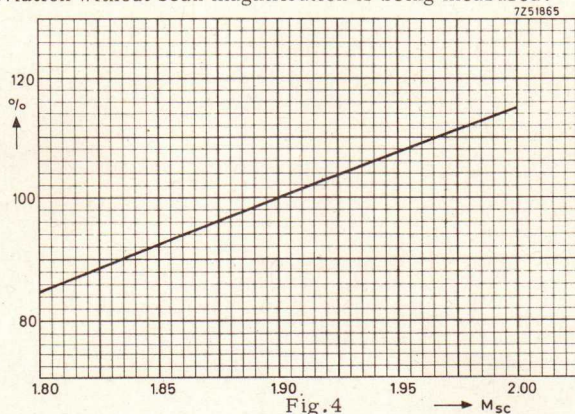

Fig.4

Line-width as a function of the scan-magnification factor (approximately)
Line-width at $M_{sc} = 1.9$ is 100%, $I_{screen} = \text{const.}$

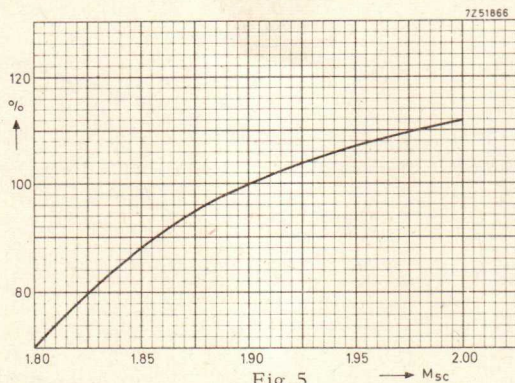

Fig. 5

Screen current as a function of the scan-magnification factor (approximately)
 Screen current at $M_{sc} = 1.9$ is 100%, $V_{g1} = \text{const.}$

For the adjustment of the scan-magnification factor the following procedure is recommended:

- Set V_{g8} and V_{g9} to 0 with respect to g_2 .
- Display a time-base line and adjust V_{g6} so that the line appears sharply focused.
- Apply a square wave signal to the vertical deflection system (the vertical parts of the trace will be out of focus but this is immaterial) and adjust the amplitude so that the height of the display has a convenient value, e.g. 30 mm.
- Set V_{g8} and V_{g9} to the appropriate values and readjust V_{g6} so that the horizontal parts of the trace are again in focus.
- Check the height of the display (e.g. for $M_{sc} = 1.9$ this height should now be 57 mm).
- If necessary, readjust V_{g9} until the desired value of M_{sc} has been obtained.

Focusing is controlled by means of the electrode voltage V_{g4} and V_{g6} . The electrodes g_5 and g_7 can be used to centre the beam with respect to the vertical and horizontal deflection systems.

The voltages of the focusing and correction electrodes can be adjusted as follows:

- Display a square-wave signal on the screen so that both horizontal and vertical traces are visible.
- Adjust V_{g6} so that the horizontal parts of the display are in focus. The vertical parts will, in general, be out of focus.
- Adjust V_{g4} so that the vertical traces are brought into focus. Now the horizontal parts of the display will be out of focus again.
- Repeat b) and c) successively until both vertical and horizontal traces are simultaneously in focus.
- Adjust V_{g3} for minimum width of a horizontal line. If necessary, readjust focusing voltages V_{g4} and V_{g6} .

- f. Adjust V_{g7} for equal brightness at the left-hand and right-hand edges of the display area. If necessary, readjust the focus by means of V_{g6} .
- g. Adjust V_{g5} so that the position of a horizontal trace not deflected in the vertical direction is at the centre of the vertical useful scan. If necessary, readjust the focus by means of V_{g4} .

If the graticule is not fully covered by the scanned area the image should be shifted by adjusting the correction coil current (see page 16) before the adjustment of V_{g5} is made.

The procedure for the adjustment of the scan-magnification factor and for focusing, as described above, seems to be rather complicated.

However, in practice it will be sufficient to adjust V_{g0} to its nominal value without determining the scan-magnification factor for each individual tube. As to focusing, the user can, with some experience, achieve the best setting with very few adjustments.

Post-deflection acceleration

The use of a p.d.a. shield (mesh) ensures a high deflection sensitivity. A geometry control electrode, g_{11} , serves for the correction of pin cushion or barrel distortion of the pattern. In order to suppress background illumination due to secondary electrons originating from the p.d.a. shield g_{12} , this shield should be kept 12 V negative with respect to g_{11} whereas the voltage of the interplate shield, g_{10} should be equal to the mean x-plate potential.

HEATING: Indirect by A.C. or D.C.; parallel supply

Heater voltage	V_f	6.3 V
Heater current	I_f	300 mA

CAPACITANCES

x_1 to all other elements except x_2	$C_{x_1(x_2)}$	4.5 pF
x_2 to all other elements except x_1	$C_{x_2(x_1)}$	4.5 pF
x_1 to x_2	$C_{x_1x_2}$	2.7 pF
Control grid to all other elements	C_{g1}	6 pF
Cathode to all other elements	C_k	5 pF
External conductive coating to all other elements	C_m	1500 pF

1) Clear area for light conductor.

2) These dimensions apply to the illumination plate which will always be within the limits $117 \pm 1.5 \times 79 \pm 1.5$ mm of the tube face.

3) The soldering tags will be situated within a rectangle of 60 mm x 40 mm on the rearside of the tube.

MECHANICAL DATA

Dimensions in mm

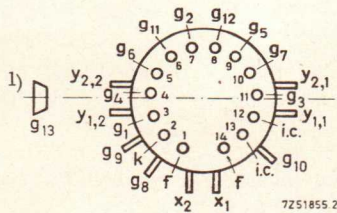
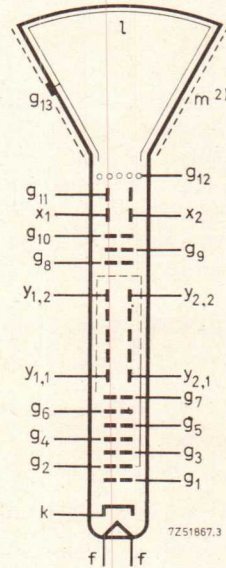
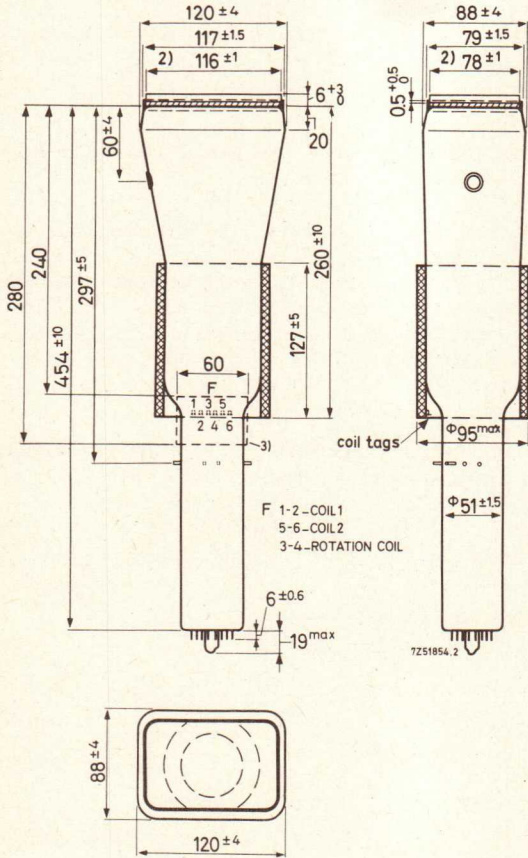

- 1) The centre of the contact is located within a square of 10 mm x 10 mm around the true geometrical position.
- 2) The external conductive coating must be earthed.

Notes: see page 7

MECHANICAL DATA (continued)

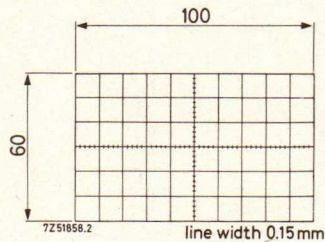
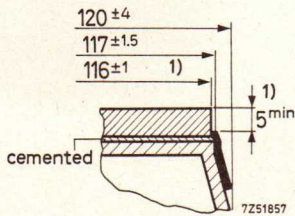

Mounting position: any

The tube should not be supported by the base alone and under no circumstances should the socket be allowed to support the tube.

Dimensions and connections

See also outline drawing

Overall length (socket and front glass plate inclusive)	max.	492	mm
Face dimensions	max.	124 x 92	mm ²
<u>Net weight</u>	approx.	1300	g
<u>Base</u>		14-pin	all glass

Accessories

Socket	type 55566
Final accelerator contact connector	type 55563A
Side contact connector	type 55561
Mu-metal screen	type 55582

In order to avoid damage to the side contacts the narrower end of the mu-metal screen should have an internal diameter of not less than 65 mm.

1) see page 7

FOCUSING electrostatic 1)

DEFLECTION double electrostatic

x plates symmetrical

The y deflection system consists of a symmetrical delay line system.

Characteristic impedance $2 \times 150 \Omega$

Bandwidth (-3 dB) 800 MHz 2)

Rise time $< 0.45 \text{ ns}$ 3)

If use is made of the full deflection capabilities of the tube the deflection plates will intercept part of the electron beam: hence a low impedance deflection plate drive is desirable.

Angle between x and y traces 90° 4) (see page 14 "Correction coils")

1) Because of the applications of a quadrupole lens for the magnification of the vertical deflection, two more quadrupole lenses are used for focusing. Therefore, controls for two voltages have to be provided.

2) The band-width is defined as the frequency at which the vertical deflection sensitivity is 3 dB lower than at D.C.

3) The rise-time is defined as the time interval between 10% and 90% of the final value of deflection when an ideal step-function signal is applied to the vertical deflection system. If the actual signal has an appreciable rise-time τ_2 , the rise-time of the tube can be determined from

$$\tau_1 = \sqrt{\tau^2 - \tau_2^2}$$

where τ is the rise-time observed on the display.

This should be measured after the angle between the x-traces and y-traces has been corrected by means of the correction coils, otherwise two measurements have to be taken (using either a different polarity of the vertical deflection signal or different direction of the time-base sweep) and the true value of τ has to be calculated as the arithmetic mean of the two results.

4) Deviations from the orthogonality of traces can be eliminated by means of correction coils.

LIMITING VALUES (absolute max. rating system)

Final accelerator voltage	$V_{g13(\ell)}$	max.	18 000 V
		min.	9 000 V
Post-deflection shield voltage	V_{g12}	max.	3 100 V
Geometry control electrode voltage	V_{g11}	max.	3 100 V
Interplate shield voltage	V_{g10}	max.	3 100 V
Scan-magnifier electrode voltage	V_{g9}	max.	3 000 V
Correction electrode voltage	V_{g8}	max.	3 200 V
Focusing electrode voltages	V_{g6}	max.	3 000 V
		$-V_{g6-g2}$	max. 1 000 V
	V_{g4}	max.	3 000 V
	$-V_{g4-g2}$	max.	1 000 V
Beam centering electrode voltages	V_{g7}	max.	3 100 V
	V_{g5}	max.	3 100 V
Spot correction electrode voltage	V_{g3}	max.	3 100 V
First accelerator voltage	V_{g2}	max.	3 000 V
		min.	2 000 V
Control grid voltage, negative	$-V_{g1}$	max.	200 V
		positive	V_{g1}
Cathode to heater voltage	V_{kf}	cathode positive	max. 125 V
		cathode negative	$-V_{kf}$
Voltage between first accelerator and any deflection electrode	$V_{g2 x}$	max.	500 V
	$V_{g2 y}$	max.	500 V
Screen dissipation	W_{ℓ}	max.	3 mW/cm ²
Average cathode current	I_k	max.	300 μ A

Notes to page 11

- 1) This voltage should be adjusted for optimum pattern geometry.
- 2) This voltage should be equal to the mean x-plate potential.
- 3) The range indicated corresponds to a scan magnification factor, M_{SC} , i.e. the ratio by which the vertical deviation on the screen is increased, in the approximate range $1.8 < M_{SC} < 2.0$, and the tube should not be operated outside this range. Within this range, line width and screen current at a fixed value of the control grid voltage are increasing functions of M_{SC} . The best compromise between brightness and line width is usually found at $M_{SC} \approx 1.9$ which corresponds to $V_{g9-g2} \approx 310$ V.
- 4) For minimum defocusing of vertical lines near the upper and lower edges of the scanned area this voltage should be adjusted approximately to the value indicated. Since the value V_{g8-g2} has some effect on the scan magnification factor both V_{g8} and V_{g9} should be connected to g_2 when the deviation without scan magnification is to be measured.
- 5) This voltage should be adjusted for equal brightness in the x-direction with respect to the electrical centre of the tube.
- 7) These voltages should be stabilized to within 1 V.
- 8) This voltage should be adjusted for minimum width of a horizontal line.
- 9) For a scan magnification factor $M_{SC} = 1.9$.
In the above mentioned range of V_{g9-g2} the vertical deflection factor will vary approximately $\pm 5\%$.
- 10) The sensitivity at a deflection of less than 75% of the useful scan will not differ from the sensitivity at a deflection of 25% of the useful scan by more than the indicated value.
- 11) A rectangle of 98 mm x 58.2 mm is concentrically aligned with the internal graticule of the tube. With optimum corrections applied, the edges of a raster will fall between this rectangle and the boundary lines of the internal graticule.

CORRECTIONS COILS

The tube is provided with a coil unit consisting of:

1. A pair of coils (No.1 and 2), with approx. 220Ω resistance per coil, for
 - a) correction of the orthogonality of the x- and y-traces so that the angle between these traces at the centre of the screen can be made exactly 90° .
 - b) vertical shift of the scanned area.
2. A single coil (No.3) with approx. 550Ω resistance, for image rotation (alignment of the x-trace with the x-lines of the graticule).

Orthogonality and shift

The change in the angle between the traces and the shift of the scanned area will be proportional to the algebraic sum and the algebraic difference of the currents in the coils No.1 and 2.

Under typical operating conditions and with the coil unit closely surrounded by a mu-metal shield, the currents required are max. 5 mA per degree of angle correction and max. 2 mA per millimeter shift. The supply circuit for these coils should be so designed that in each coil a maximum current of 20 mA, with either polarity, can be produced.

If a wider mu-metal shield is used the above-mentioned values have to be multiplied by a factor K ($1 < K < 2$) the value of which depends on the dimensions of the shield and approaches 2 for the case no shield is present.

Image rotation

Under typical operating conditions, a current of max. 45 mA will be required for the alignment.

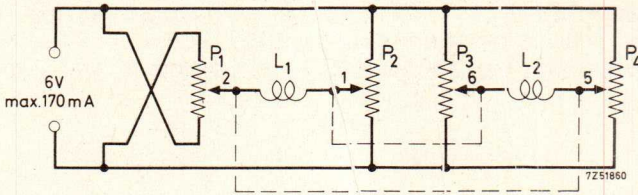

Fig.1

With the above circuit almost independent control for shift and angle correction is achieved. This facilitates the correct adjustment to a great extent.

The dissipation in the potentiometers can be reduced considerably if the requirement of independent controls is dropped.

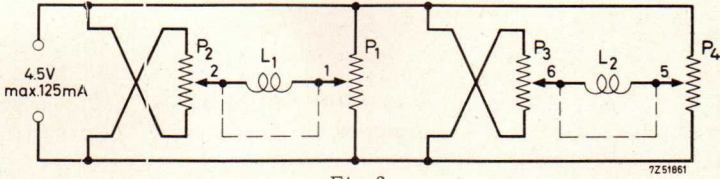

Fig. 2

P₁, P₂ potentiometers 220 Ω, 1 watt: ganged
 P₃, P₄ potentiometers 220 Ω, 1 watt: ganged

A further reduction of the dissipation can be obtained by providing a commutator for each coil (see circuit fig. 3).

The procedure of adjustment will then become more complicated but it should be kept in mind that a readjustment is necessary only when the tube has to be replaced.

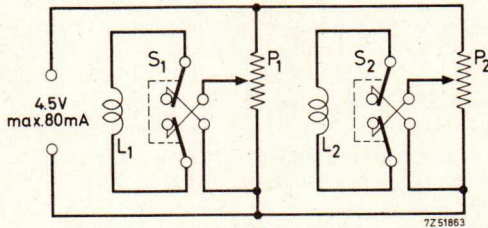

Fig. 3

P₁, P₂ potentiometers 220 Ω, 1 watt
 S₁, S₂ commutators

A suitable circuit for the image rotating coil is given in fig. 4.

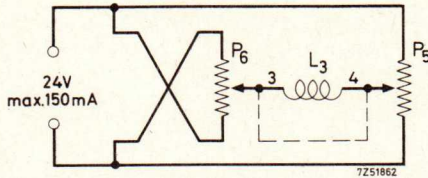

Fig. 4

P₅, P₆ potentiometers 500 Ω, 3 watt: ganged

The following procedure of adjustment is recommended

- a. Align the x-trace with the graticule by means of the image rotating coil.
- b. With the tube fully scanned in the vertical direction, the image has to be shifted so that the graticule is fully covered. With the circuit according to fig.1 this is done by means of the ganged potentiometers P_1 and P_4 .
- c. Adjustment of orthogonality by means of the ganged potentiometers P_2 and P_3 . A slight readjustment of P_1 and P_4 may be necessary afterwards.
- d. Readjustment of the image rotation if necessary.

With a circuit according to fig.2 or 3 these corrections have to be performed by means of successive adjustments of the currents in the coils.

The most convenient deflection signal is a square wave form permitting an easy and fairly accurate visual check of orthogonality.

ILLUMINATION OF THE GRATICULE

To illuminate the internal graticule a light conductor (e.g. of perspex) should be used. In order to achieve the most efficient light conductance, the holes for the lamps and the edge adjacent to the tube should be polished, and the distance between the perspex plate and the tube should be as small as possible. It is advisable to apply reflective material to the outer circumference and, if possible, also to the upper and lower faces of the light conductor. The thickness of the conductor should not exceed 3 mm, and its position relative to the frontplate of the tube should be adjusted for optimum illumination of the graticule lines.

INSTRUMENT CATHODE-RAY TUBE

14 cm diagonal, rectangular flat faced oscilloscope tube with mesh and metal backed screen.

QUICK REFERENCE DATA

Final accelerator voltage	$V_{g7(\ell)}$	10	kV
Display area		100 x 80	mm ²
Deflection coefficient, horizontal	M_x	15,5	V/cm
vertical	M_y	4,2	V/cm

SCREEN: Metal backed phosphor

	Colour	Persistence
D14-120GH	green	medium short

Useful screen area	>	100 x 80	mm ²
Useful scan at $V_{g7(\ell)}/V_{g2, g4} = 6,7$	>	100	mm
horizontal	>	80	mm
vertical	<	6	mm
Spot eccentricity in horizontal and vertical directions	<	6	mm

HEATING: Indirect by a.c. or d.c.; parallel supply

Heater voltage	V_f	6,3	V
Heater current	I_f	300	mA

MECHANICAL DATA

Dimensions and connections

See also outline drawing

Overall length (socket included)	<	385	mm
Face dimensions	<	100 x 120	mm
<u>Net mass</u>		approx. 900	g

Base 14-pin all-glass

Dimensions in mm

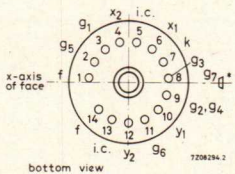
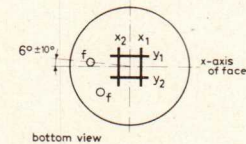

recommended position of rotating coil

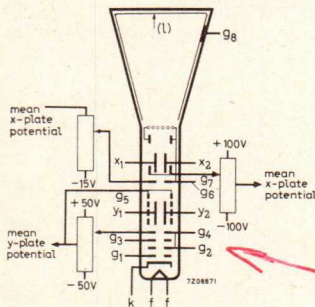
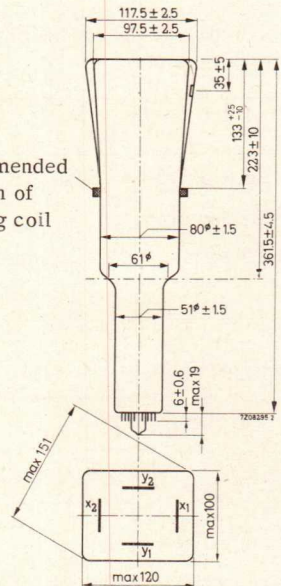

electrode numbering ≠ D14-120-191-

* The centre of the contact is located within a square of 10 mm x 10 mm around the true geometrical position.

Mounting position: any

The tube should not be supported by the base alone; under no circumstances should the socket be allowed to support the tube.

Accessories

Socket (supplied with tube)	type	55566
Final accelerator contact connector	type	55563A
Mu-metal shield	type	55581

FOCUSING	electrostatic
DEFLECTION	double electrostatic
x plates	symmetrical
y plates	symmetrical

If use is made of the full deflection capabilities of the tube the deflection plates will intercept part of the electron beam; hence a low impedance deflection plate drive is desirable.

Angle between x and y traces $90^\circ \pm 1^\circ$

Angle between x trace and the horizontal axis of the face $< 5^\circ$ ¹⁾.

LINE WIDTH

Measured with the shrinking raster method under typical operating conditions, adjusted for optimum spot size at a beam current $I_f = 10 \mu\text{A}$.

Line width at the centre of the screen	l. w.	0,40	mm
over the whole screen area	l. w. av. <	0,45	mm

CAPACITANCES

x ₁ to all other elements except x ₂	C _{x1(x2)}	6,5	pF
x ₂ to all other elements except x ₁	C _{x2(x1)}	6,5	pF
y ₁ to all other elements except y ₂	C _{y1(y2)}	5,0	pF
y ₂ to all other elements except y ₁	C _{y2(y1)}	5,0	pF
x ₁ to x ₂	C _{x1x2}	2,2	pF
y ₁ to y ₂	C _{y1y2}	1,7	pF
Control grid to all other elements	C _{g1}	5,5	pF
Cathode to all other elements	C _k	4,5	pF

¹⁾ To align the x trace with the horizontal axis of the screen, the whole picture can be rotated by means of a rotation coil. This coil will have 50 ampere turns for the indicated maximum rotation of 5° and should be positioned as indicated in the drawing.

TYPICAL OPERATING CONDITIONS

Final accelerator voltage	$V_{g7(\ell)}$	10	kV
Interplate shield voltage	V_{g6}	1500	V
Geomrty control voltage	ΔV_{g6}	± 15	V 1)
Deflection plate shield voltage	V_{g5}	1500	V 2)
Focusing electrode voltage	V_{g3}	250 to 350	V
First accelerator voltage	$V_{g2, g4}$	1500	V
Astigmatism control voltage	$\Delta V_{g2, g4}$	± 50	V 3)
Control voltage for visual extinction of focused spot	V_{g1}	-20 to -60	V
Grid drive for 10 μ A screen current		approx. 12	V
Deflection coefficient, horizontal	M_x	15,5	V/cm
		< 16	V/cm
vertical	M_y	4,2	V/cm
		< 4,6	V/cm
Deviation of linearity of deflection		< 2	% 4)
Geometry distortion		See note 5	
Useful scan, horizontal		> 100	mm
		> 80	mm

LIMITING VALUES (Absolute max. rating system)

Final accelerator voltage	$V_{g7(\ell)}$	max.	11	kV
		min.	9	kV
Interplate shield voltage and geometry control electrode voltage	V_{g6}	max.	2200	V
Deflection plate shield voltage	V_{g5}	max.	2200	V
Focusing electrode voltage	V_{g3}	max.	2200	V
First accelerator and astigmatism control electrode voltage	$V_{g2, g4}$	max.	2200	V
		min.	1350	V
Control grid voltage,	$-V_{g1}$	max.	200	V
		min.	0	V
Cathode to heater voltage	V_{kf}	max.	125	V
		max.	125	V
Voltage between astigmatism control electrode and any deflection plate	$V_{g4/x}$	max.	500	V
		max.	500	V
Grid drive, average		max.	20	V
Screen dissipation	W_ℓ	max.	8	mW/cm ²
Ratio $V_{g7(\ell)}/V_{g2, g4}$	$V_{g7(\ell)}/V_{g4}$	max.	6, 7	

Notes see page 5

NOTES

- 1) This tube is designed for optimum performance when operating at a ratio $V_{g7(\ell)}/V_{g2, g4} = 6, 7$.
The geometry electrode voltage should be adjusted within the indicated range (values with respect to the mean x plate potential).
A negative control voltage will cause some pincushion distortion and less background light, a positive control voltage will give some barrel distortion and a slight increase of background light.
- 2) The deflection plate shield voltage should be equal to the mean y plate potential.
The mean x plate and y plate potentials should be equal for optimum spot quality.
- 3) The astigmatism control electrode voltage should be adjusted for optimum spot shape.
For any necessary adjustment its potential will be within the stated range.
- 4) The sensitivity at a deflection of less than 75% of the useful scan will not differ from the sensitivity at a deflection of 25% of the useful scan by more than the indicated value.
- 5) A graticule, consisting of concentric rectangles of 95 mm x 95 mm and 93 mm x 73,6 mm is aligned with the electrical x axis of the tube. With optimum correction potentials applied a raster will fall between these rectangles.



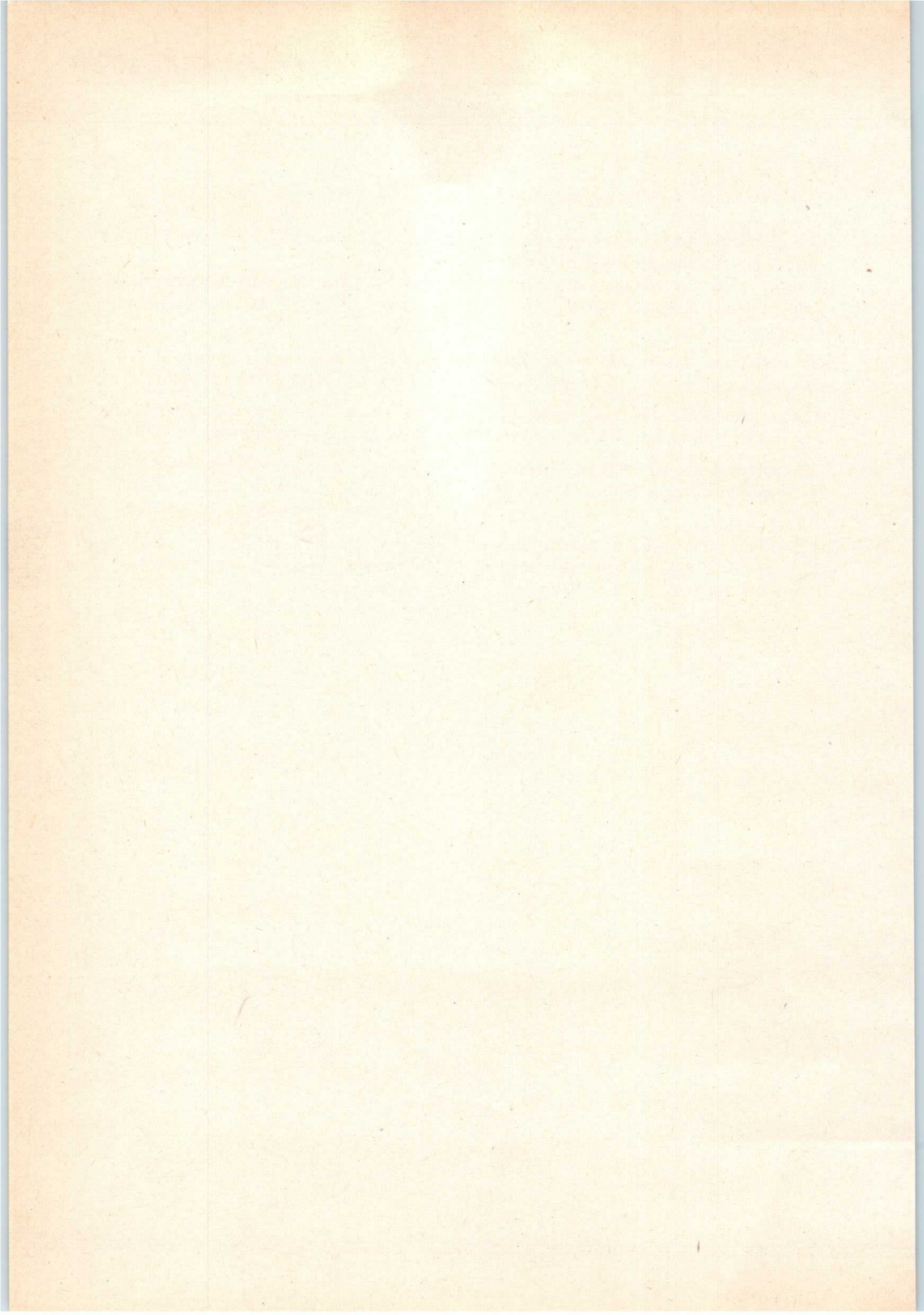

INSTRUMENT CATHODE-RAY TUBE

14 cm diagonal, rectangular flat-faced oscilloscope tube with mesh and metal backed screen. The tube has side connections to the x- and y-plates, and is intended for use in transistorized oscilloscopes up to a frequency of 50 MHz.

QUICK REFERENCE DATA			
Final accelerator voltage	$V_{g8(\ell)}$	10	kV
Display area		100 x 80	mm ²
Deflection coefficient, horizontal	M_x	15,5	V/cm
vertical	M_y	4,2	V/cm

SCREEN : Metal backed phosphor

	Colour	Persistence
D14-121GH	green	medium short

Useful screen area	> 100 x 80	mm ²
Useful scan at $V_{g8(\ell)}/V_{g2, g4} = 6, 7$, horizontal	> 100	mm
vertical	> 80	mm
Spot eccentricity in horizontal and vertical directions	< 6	mm

HEATING

Indirect by a.c. or d.c.; parallel supply

Heater voltage	V_f	6,3	V
Heater current	I_f	300	mA

MECHANICAL DATA

Dimensions in mm

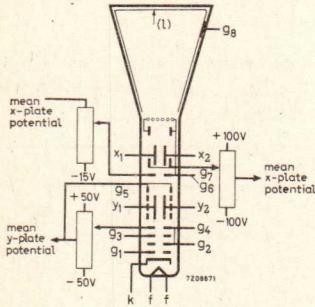

recommended position of rotating coil

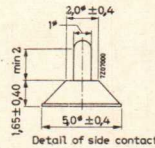
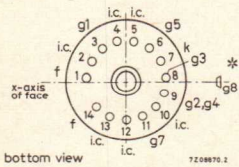
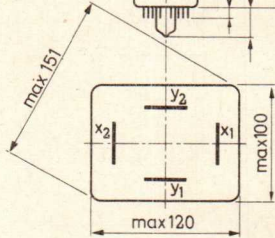
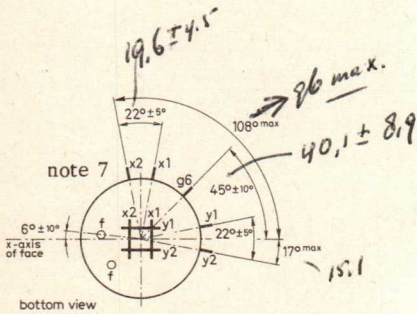
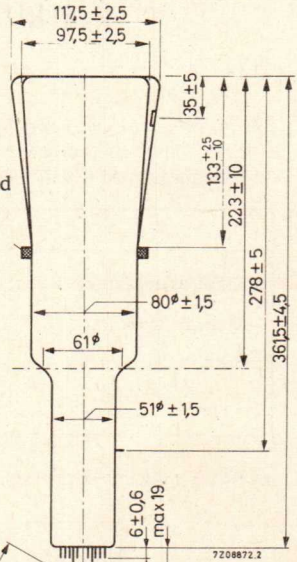

* The centre of the contact is located within a square of 10 mm x 10 mm around the true geometrical position.

Mounting position: any

The tube should not be supported by the base alone and under no circumstances should the socket be allowed to support the tube.

Dimensions and connections

See also outline drawing

Overall length (socket included) < 385 mm

Face dimensions < 100 x 120 mm

Net mass approx. 900 gBase 14-pin all glassAccessories

Socket (supplied with tube) type 55566

Final accelerator contact connector type 55563A

Mu-metal shield type 55581A

CAPACITANCES x_1 to all other elements except x_2 $C_{x1(x2)}$ 5,5 pF x_2 to all other elements except x_1 $C_{x2(x1)}$ 5,5 pF y_1 to all other elements except y_2 $C_{y1(y2)}$ 4 pF y_2 to all other elements except y_1 $C_{y2(y1)}$ 4 pF x_1 to x_2 C_{x1x2} 2,2 pF y_1 to y_2 C_{y1y2} 1,7 pFControl grid to all other elements C_{g1} 5,5 pFCathode to all other elements C_k 4,5 pF**FOCUSING** electrostatic**DEFLECTION** double electrostatic

x plates symmetrical

y plates symmetrical

If use is made of the full deflection capabilities of the tube the deflection plates will intercept part of the electron beam; hence a low impedance deflection plate drive is desirable.

Angle between x and y traces $90 \pm 1^\circ$ Angle between x trace and the horizontal axis of the face $< 5^\circ$ 1)**LINE WIDTH**

Measured with the shrinking raster method under typical operating conditions, adjusted for optimum spot size at a beam current $I_b = 10 \mu A$.

Line width at screen centre l. w. 0,40 mm

over the whole screen area l. w. av. < 0,45 mm

Notes see page 5

TYPICAL OPERATING CONDITIONS

Final accelerator voltage	$V_{g8}(\ell)$	10	kV
Geometry-control electrode voltage	V_{g7}	1500 ± 100	V 2)
Post deflection and interplate shield voltage	V_{g6}	1500	V
Background illumination control voltage	ΔV_{g6}	0 to -15	V 2)
Deflection plate shield voltage	V_{g5}	1500	V 3)
Focusing electrode voltage	V_{g3}	250 to 350	V
First accelerator voltage	$V_{g2, g4}$	1500	V
Astigmatism control voltage	$\Delta V_{g2, g4}$	± 50	V 4)
Control grid voltage for extinction of focused spot	V_{g1}	-20 to -60	V
Grid drive for 10 μ A screen current		approx.	12 V
Deflection coefficient, horizontal	M_x	av.	15,5 V/cm
		<	16 V/cm
vertical	M_y	av.	4,2 V/cm
		<	4,6 V/cm
Deviation of linearity of deflection		<	2 % 5)
Geometry distortion		See note 6	
Useful scan, horizontal		>	100 mm
		>	80 mm
vertical		>	80 mm

LIMITING VALUES (Absolute max. rating system)

Final accelerator voltage	$V_{g8}(\ell)$	max.	11 kV
		min.	9 kV
Post deflection and interplate shield voltage and geometry control electrode voltage	V_{g7}, V_{g6}	max.	2200 V
Deflection plate shield voltage	V_{g5}	max.	2200 V
Focusing electrode voltage	V_{g3}	max.	2200 V
First accelerator and astigmatism control electrode voltage	$V_{g2, g4}$	max.	2200 V
		min.	1350 V
Control grid voltage	$-V_{g1}$	max.	200 V
		min.	0 V
Cathode to heater voltage	V_{kf}	max.	125 V
		$-V_{kf}$	max.
Voltage between astigmatism control electrode and any deflection plate	$V_{g4/x}$ $V_{g4/y}$	max.	500 V
		max.	500 V
		max.	20 V
Grid drive, average		max.	20 V
Screen dissipation	W_ℓ	max.	8 mW/cm ²
Ratio $V_{g8}(\ell)/V_{g2, g4}$	$V_{g8}(\ell)/V_{g2, g4}$	max.	6, 7

For notes see page 5

NOTES

- 1) In order to align the x-trace with the horizontal axis of the screen, the whole picture can be rotated by means of a rotation coil. This coil will have 50 amp. turns for the indicated max. rotation of 5° and should be positioned as indicated on the drawing.
- 2) This tube is designed for optimum performance when operating at a ratio $V_{g8(l)} / V_{g2, g4} = 6,7$
The geometry control voltage V_{g7} should be adjusted within the indicated range (values with respect to the mean x-plate potential).
A negative control voltage on g_6 (with respect to the mean x-plate potential) will cause some pincushion distortion and less background light.
By the use of the two voltages, V_{g6} and V_{g7} , it is possible to find the best compromise between background light and raster distortion.
- 3) The deflection plate shield voltage should be equal to the mean y-plate potential. The mean x- and y-plate potentials should be equal for optimum spot quality.
- 4) The astigmatism control electrode voltage should be adjusted for optimum spot shape. For any necessary adjustment its potential will be within the stated range.
- 5) The sensitivity at a deflection of less than 75% of the useful scan will not differ from the sensitivity at a deflection of 25% of the useful scan by more than the indicated value.
- 6) A graticule, consisting of concentric rectangles of 95 mm x 75 mm and 93 mm x 73,6 mm is aligned with the electrical x axis of the tube. With optimum correction potentials applied a raster will fall between these rectangles.
- 7) To avoid damage to the side contacts the narrower end of the Mu-metal shield should have an internal diameter of not less than 64 mm.

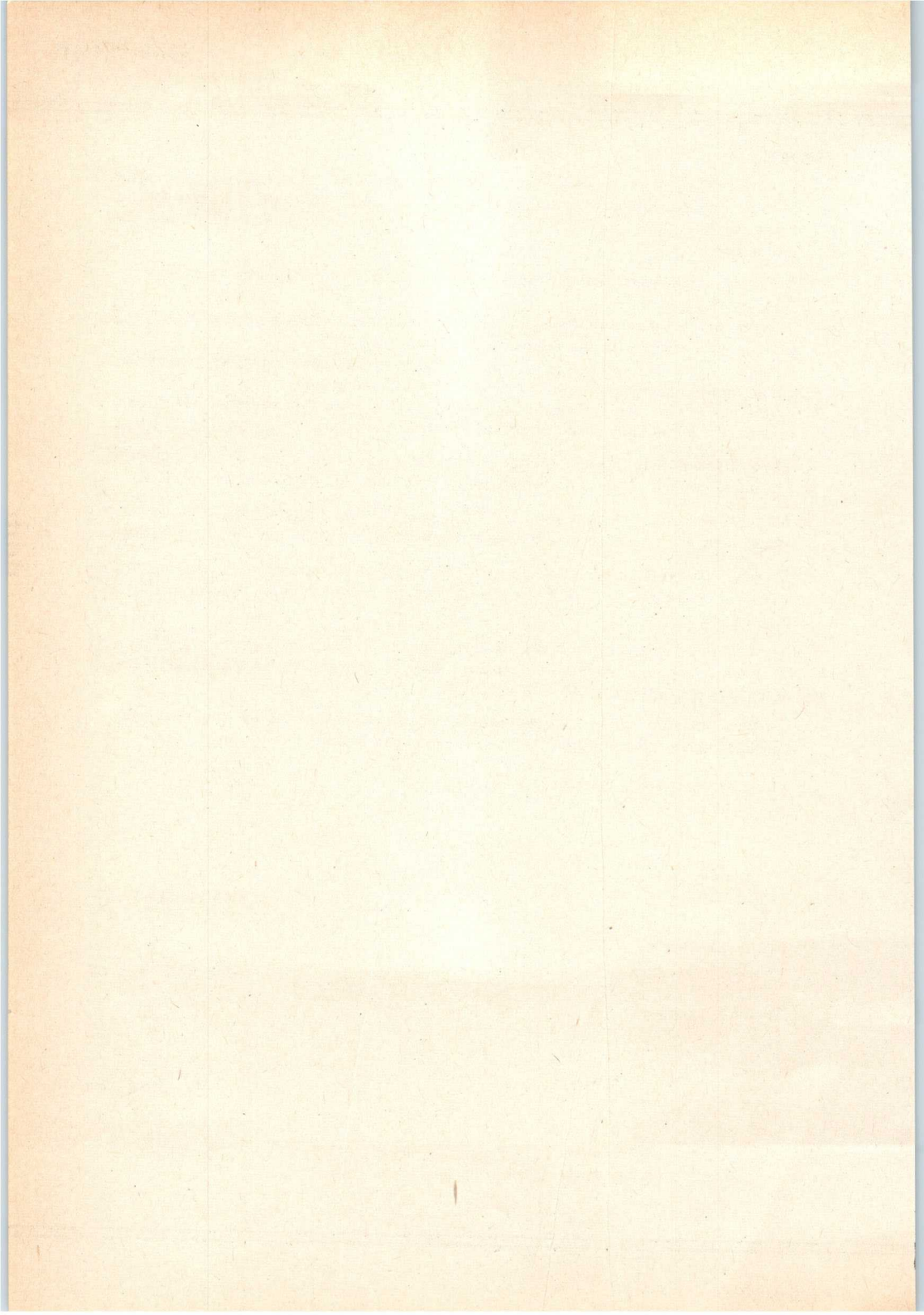

INSTRUMENT CATHODE-RAY TUBE

This type is equivalent with type D14-120 GH but provided with a rotation coil as indicated in note 1 of D14-120GH.

COIL

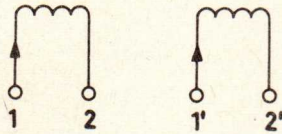

Number of turns	1 - 2	850 turns
	1' - 2'	850 turns
Resistance of coils	1 - 2	360 Ω + 10 %
	1' - 2'	375 Ω 10 %

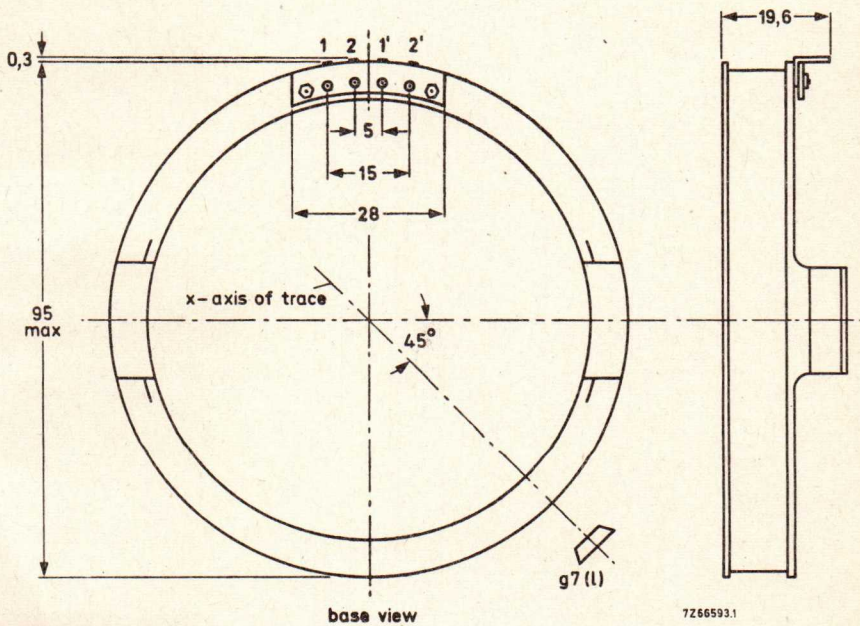

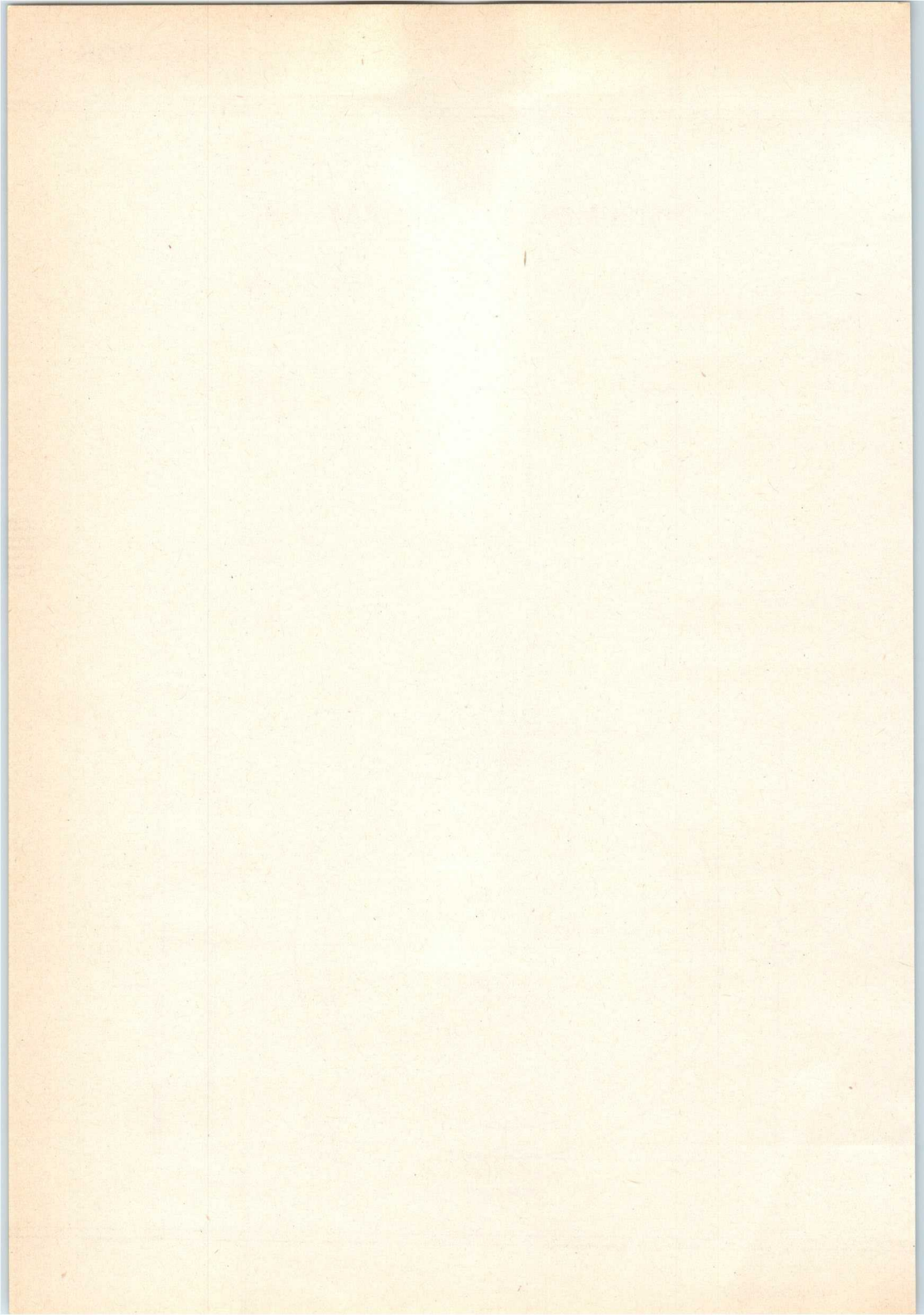

INSTRUMENT CATHODE-RAY TUBE

This type is equivalent with type D14-121GH but provided with a rotation coil as indicated in note 1 of D14-121GH.

COIL

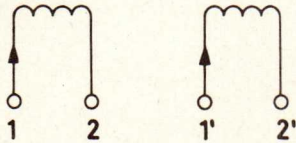

Number of turns	1 - 2	850 turns
	1' - 2'	850 turns
Resistance of coils	1 - 2	360 Ω (± 10 %)
	1' - 2'	375 Ω (± 10 %)

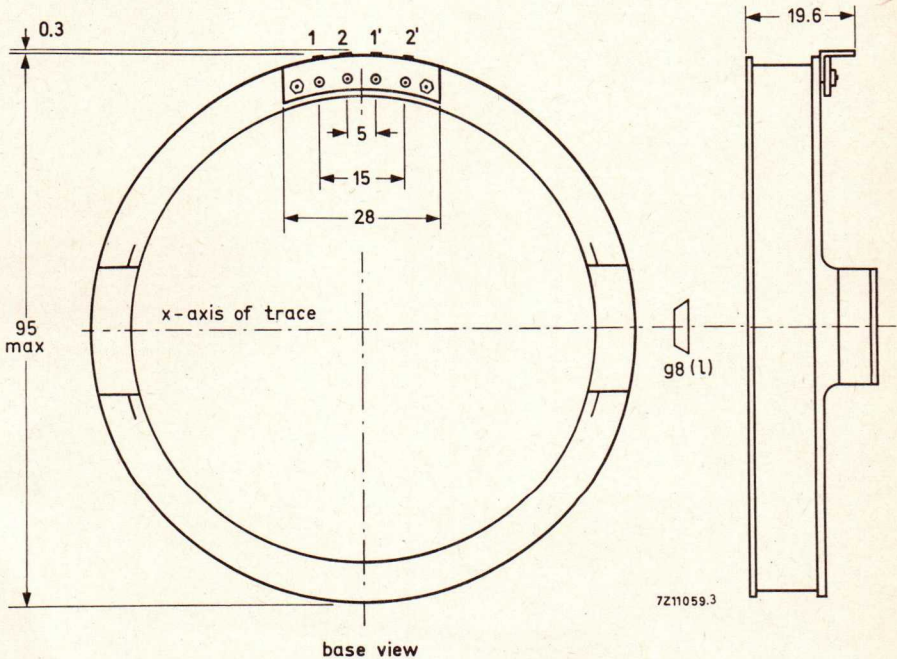

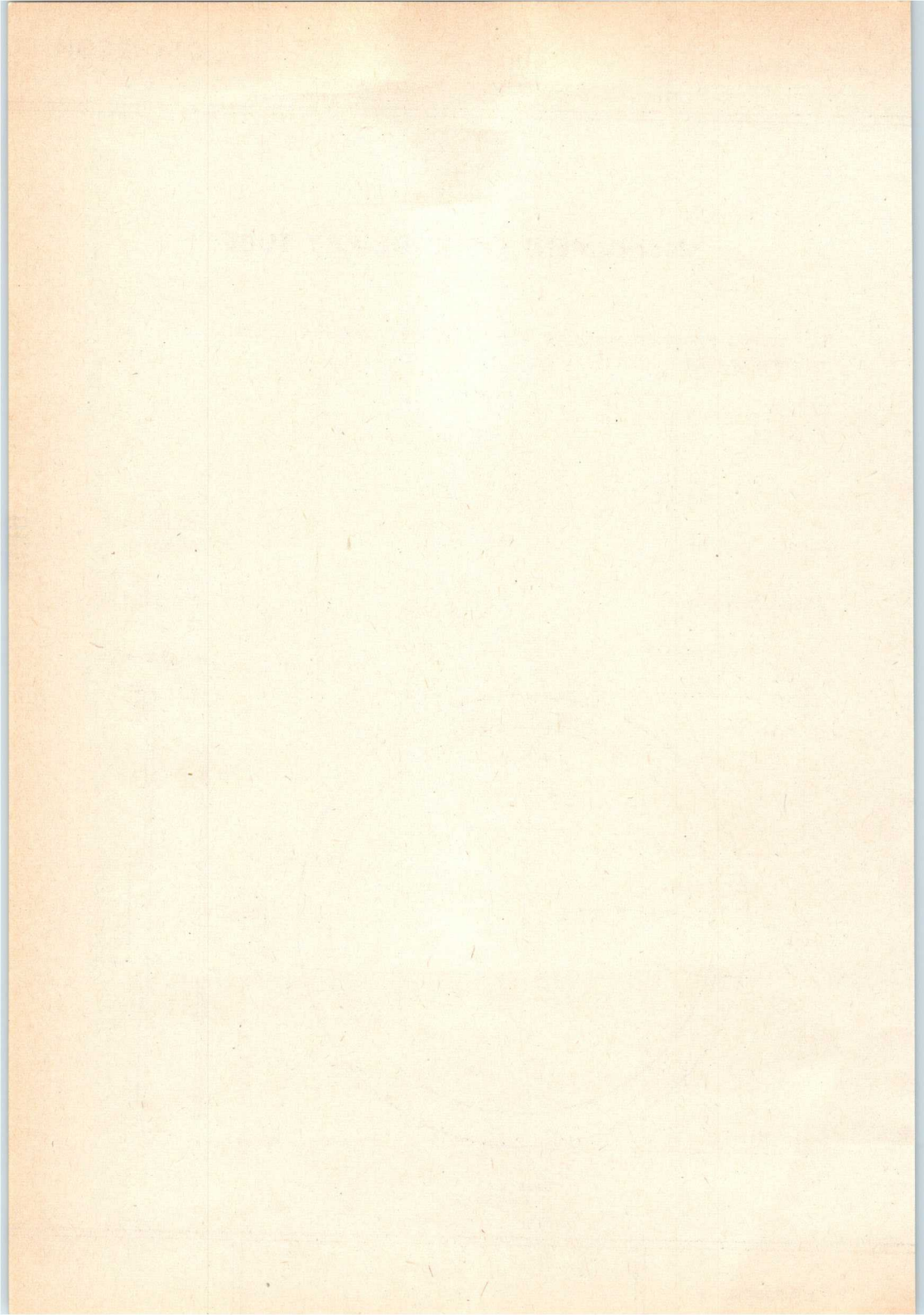

OBSOLESCE TYPE



D14-160GH/09

INSTRUMENT CATHODE-RAY TUBE

Replacement type D14-162GH/09.

The D14-162GH/09 is equivalent to the D14-160GH/09 except for the front glass plate and the correction coils.



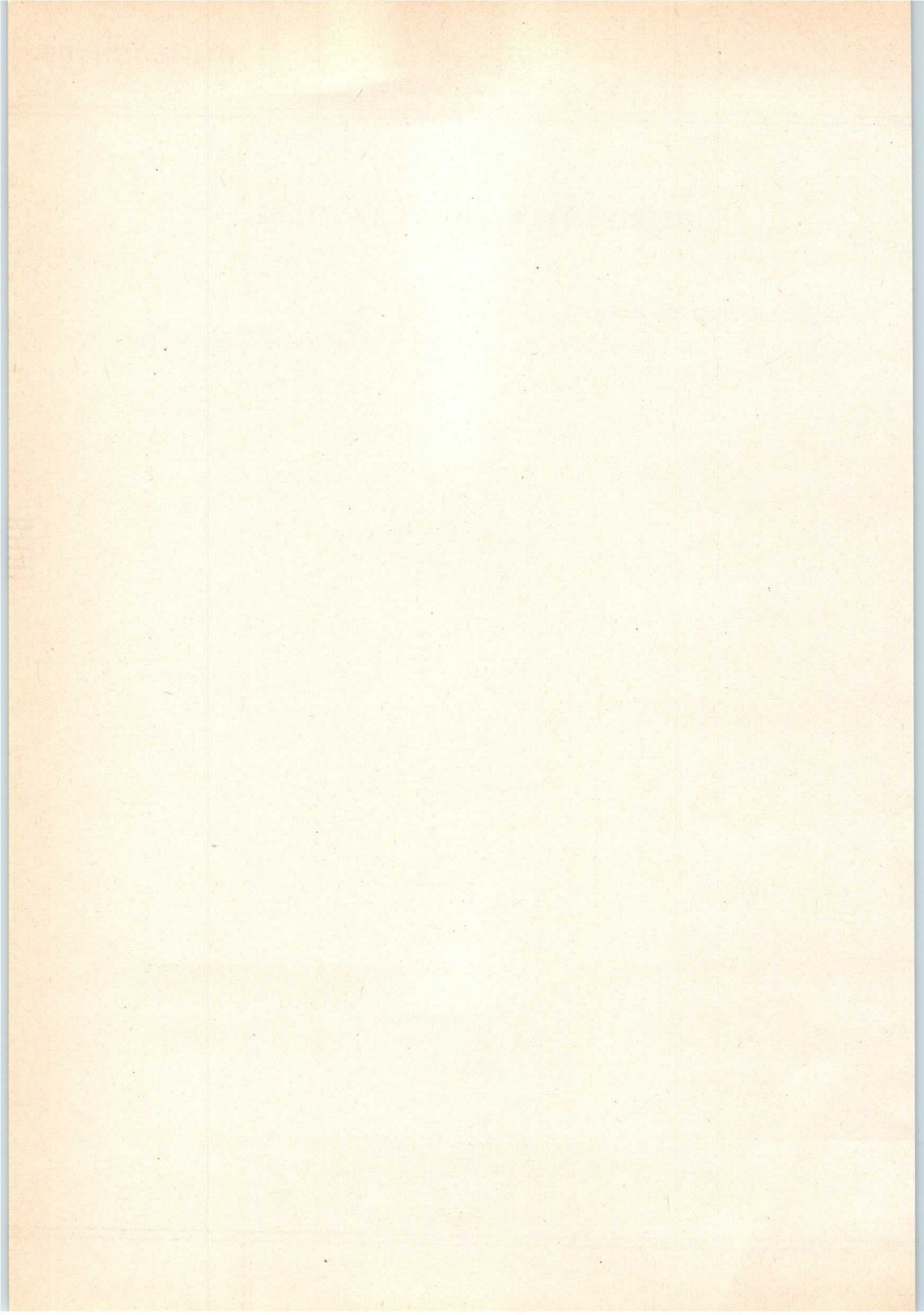

INSTRUMENT CATHODE-RAY TUBE

14 cm diagonal, rectangular flat faced oscilloscope tube with mesh and metal-backed screen. The tube has side connections to the x and y-plates and an internal graticule.

QUICK REFERENCE DATA

Final accelerator voltage	$V_{g8(\ell)}$	10	kV
Display area		100 x 80	mm^2
Deflection coefficient, horizontal	M_x	15, 2	V/cm
vertical	M_y	4, 1	V/cm

SCREEN : Metal-backed phosphor

	Colour	Persistence
D14-162GH/09	green	medium-short

Useful screen area	>	100 x 80	mm^2
Useful scan at $V_{g8(\ell)}/V_{g2, g4} = 6, 7$, horizontal	>	100	mm
vertical	>	80	mm
Spot eccentricity in horizontal direction	<	6	mm

The x-trace can be aligned with the x-lines of the graticule by means of correction coils fitted around the tube by the manufacturer (see page 5).

HEATING : Indirect by a.c. or d.c. ; parallel supply

Heater voltage	V_f	6, 3	V
Heater current	I_f	300	mA

MECHANICAL DATA

Dimensions and connections

See also outline drawing

Overall length (socket included)	<	407, 5	mm
Face dimensions	<	100 x 120	mm
<u>Net mass</u>	approx.	1200	g

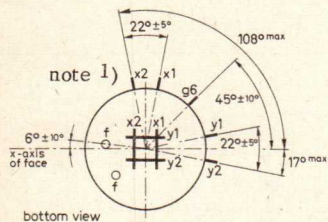
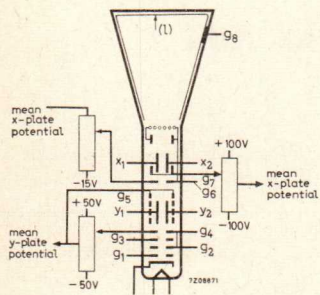

bottom view

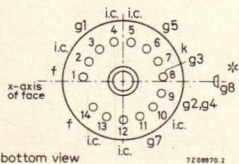

bottom view

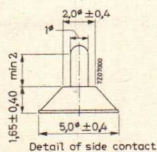

Detail of side contact

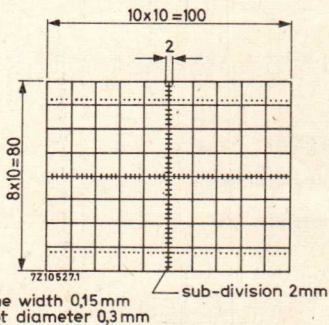
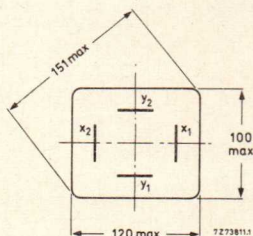
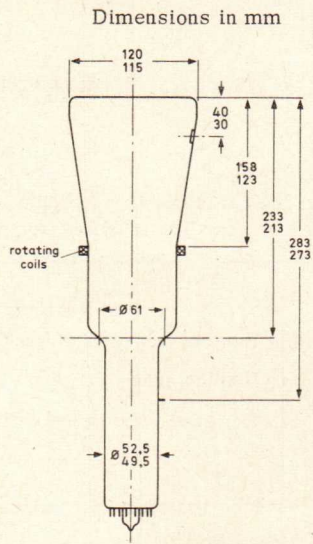
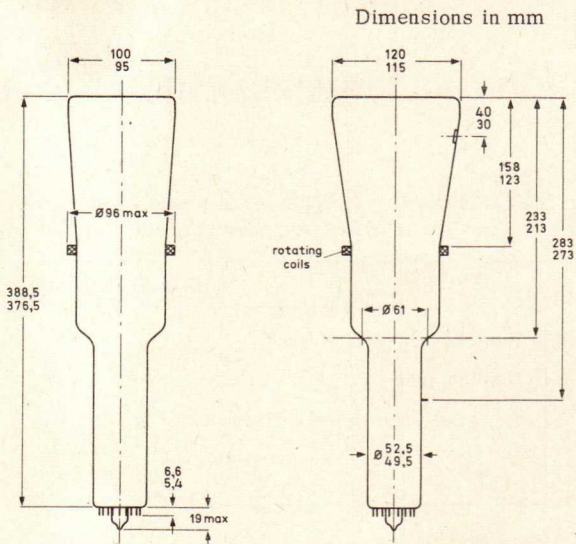

* The centre of the contact is situated within a square of 10 mm x 10 mm around the true geometrical position.

Base

14 pin all glass

Mounting position : any

The tube should not be supported by the base alone and under no circumstances should the socket be allowed to support the tube.

Accessories

Socket (supplied with tube)	type	55566	
Final accelerator contact connector	type	55563A	
Mu-metal shield	type	55585	1)

FOCUSING	electrostatic
DEFLECTION	double electrostatic
x-plates	symmetrical
y-plates	symmetrical

If use is made of the full deflection capabilities of the tube the deflection plates will intercept part of the electron beam; hence a low impedance deflection plate drive is desirable.

Angle between x and y-traces $90^\circ \pm 1^\circ$

Angle between x-trace and the horizontal axis of the face 0° See page 5 "Correction coils"

LINE WIDTH

Measured with the shrinking raster method in the centre of the screen under typical operating conditions, adjusted for optimum spot size at a beam current $I_b = 10 \mu\text{A}$.

Line width at the centre of the screen	l. w.	0,3	mm
--	-------	-----	----

CAPACITANCES

x_1 to all other elements except x_2	$C_{x1(x2)}$	5,5	pF
x_2 to all other elements except x_1	$C_{x2(x1)}$	5,5	pF
y_1 to all other elements except y_2	$C_{y1(y2)}$	3,5	pF
y_2 to all other elements except y_1	$C_{y2(y1)}$	3,5	pF
x_1 to x_2	C_{x1x2}	2	pF
y_1 to y_2	C_{y1y2}	1,6	pF
Control grid to all other elements	C_{g1}	5,5	pF
Cathode to all other elements	C_k	4	pF

1) See page 5.

TYPICAL OPERATING CONDITIONS

Final accelerator voltage	$V_{g8(\ell)}$	10	kV
Geometry control electrode voltage	V_{g7}	1500 ± 100	V 2)
Post deflection and interplate shield voltage	V_{g6}	1500	V
Background illumination control voltage	ΔV_{g6}	0 to -15	V 2)
Deflection plate shield voltage	V_{g5}	1500	V 3)
Focusing electrode voltage	V_{g3}	450 to 550	V
First accelerator voltage	$V_{g2, g4}$	1500	V
Astigmatism control voltage	$\Delta V_{g2, g4}$	± 50	V 4)
Control grid voltage for visual extinction of focused spot	V_{g1}	-30 to -70	V
Grid drive for 10 μ A screen current		approx. 20	V
Deflection coefficient, horizontal	M_x	15, 2	V/cm
		< 16	V/cm
vertical	M_y	4, 1	V/cm
		< 4, 4	V/cm
Deviation of linearity of deflection		< 2	% 5)
Geometry distortion		See note 6	
Useful scan, horizontal		> 100	mm
	vertical	> 80	mm

LIMITING VALUES (Absolute max. rating system)

Final accelerator voltage	$V_{g8(\ell)}$	max.	13	kV
		min.	9	kV
Post deflection and interplate shield voltage and geometry control electrode voltage	V_{g7}, V_{g6}	max.	2200	V
Deflection plate shield voltage	V_{g5}	max.	2200	V
Focusing electrode voltage	V_{g3}	max.	2200	V
First accelerator and astigmatism control electrode voltage	$V_{g2, g4}$	max.	2200	V
		min.	1350	V
Control grid voltage	$-V_{g1}$	max.	200	V
		min.	0	V
Cathode to heater voltage	V_{kf}	max.	125	V
		$-V_{kf}$	max.	125
Voltage between astigmatism control electrode and any deflection plate	$V_{g4/x}$	max.	500	V
		$V_{g4/y}$	max.	500
Grid drive, average		max.	30	V
Screen dissipation	W_ℓ	max.	8	mW/cm ²
Ratio $V_{g8(\ell)}/V_{g2, g4}$	$V_{g8(\ell)}/V_{g2, g4}$	max.	6, 7	

Notes see page 5.

NOTES

- 1) To avoid damage to the side contacts the narrower end of the mu-metal shield should have an internal diameter of not less than 64 mm.
- 2) This tube is designed for optimum performance when operating at a ratio $V_{g8(\ell)}/V_{g2g4}$ $V_{g8(\ell)}/V_{g2, g4} = 6, 7$.
The geometry control voltage V_{g7} should be adjusted within the indicated range (values with respect to the mean x-plate potential).
A negative control voltage on g_6 (with respect to the mean x-plate potential) will cause some pincushion distortion and less background light.
By the use of two voltages, V_{g6} and V_{g7} , it is possible to find the best compromise between background light and raster distortion.
If a fixed voltage on V_{g6} is required this voltage should be 10 V lower than the mean x-plate potential.
- 3) The deflection plate shield voltage should be equal to the mean y-plate potential.
The mean x and y-plate potentials should be equal for optimum spot quality.
- 4) The astigmatism control electrode voltage should be adjusted for optimum spot shape.
For any necessary adjustment its potential will be within the stated range.
- 5) The sensitivity at a deflection of less than 75% of the useful scan will not differ from the sensitivity at a deflection of 25% of the useful scan by more than the indicated value.
- 6) A graticule, consisting of concentric rectangles of 95 mm x 75 mm and 93 mm x 73,6 mm is aligned with the electrical x-axis of the tube. With optimum corrections applied a raster will fall between these rectangles.

CORRECTION COILS

General

The D14-1626H/09 is provided with a pair of coils L1 and L2 for image rotation which enable the alignment of the x-trace with the x-lines of the graticule.

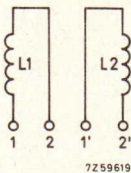

The image rotation coils are wound concentrically around the tube neck. Under typical operating conditions 50 ampere-turns are required for the maximum rotation of 5° . Both coils have 850 turns. This means that a current of < 30 mA per coil is required which can be obtained by using a 24 V supply when the coils are connected in series, or a 12 V supply when they are in parallel.

Connecting the coils

The coils have been connected to the 4 soldering tags as follows:

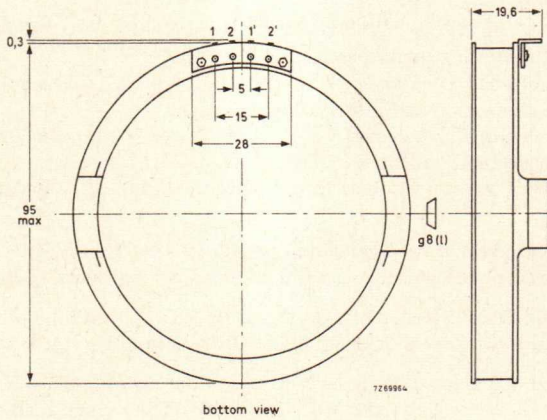

INSTRUMENT CATHODE-RAY TUBE

14 cm diagonal rectangular flat-faced oscilloscope tube with domed post-deflection acceleration mesh, sectioned y-plates, and metal-backed screen with internal graticule.

QUICK REFERENCE DATA

Final accelerator voltage	$V_{g0}(\ell)$	20	kV
Display area		100 x 80	mm ²
Deflection coefficient, horizontal vertical	M_x	9	V/cm
	M_y	3	V/cm

SCREEN

Metal-backed phosphor

	colour	persistence
D14-240GH/37	green	medium short

Useful screen dimensions > 100 x 80 mm

Spot eccentricity in horizontal
and vertical directions < 6 mm

HEATING

Indirect by a.c. or d.c.; parallel supply

Heater voltage	V_f	6,3	V
Heater current	I_f	300	mA

MECHANICAL DATA

Mounting position: any

The tube should not be supported by the base alone and under no circumstances should the socket be allowed to support the tube.

Dimensions and connections

See also outline drawing

Overall length (socket included) < 385 mm

Face dimensions < 120 x 100 mm

MECHANICAL DATA (continued)

<u>Net mass</u>	≈ 900 g
<u>Base</u>	14 pin, all glass
<u>Accessories</u>	
Socket (supplied with tube)	type 55566
Side contact connector (12 required)	type 55561
Final accelerator contact connector	note 1)
Mu-metal shield	note 2)

FOCUSING

electrostatic

DEFLECTION

double electrostatic

x-plates

symmetrical

y-plates

symmetrical

Angle between x and y traces

90°

Angle between x-trace and x-axis of
the internal graticule

0°

See also "Correction coils"

If use is made of the full deflection capabilities of the tube the deflection plates will intercept part of the electron beam; hence a low impedance deflection plate drive is desirable.

→ **CAPACITANCES**

x_1 to all other elements except x_2	$C_{x_1(x_2)}$	4,5	pF
x_2 to all other elements except x_1	$C_{x_2(x_1)}$	4,5	pF
$y_{1.1}$ to all other elements except $y_{2.1}$	$C_{y_{1.1}(y_{2.1})}$	1,3	pF
$y_{2.1}$ to all other elements except $y_{1.1}$	$C_{y_{2.1}(y_{1.1})}$	1,3	pF
x_1 to x_2	$C_{x_1x_2}$	3	pF
$y_{1.1}$ to $y_{2.1}$	$C_{y_{1.1}y_{2.1}}$	0,7	pF
Control grid to all other elements	C_{g_1}	5,5	pF
Cathode to all other elements	C_k	4,5	pF

1) The connection to the final accelerator electrode is made by means of an EHT cable attached to the tube.

2) The diameter of the mu-metal shield should be large enough to avoid damage to the side contacts.

DIMENSIONS AND CONNECTIONS

Dimensions in mm

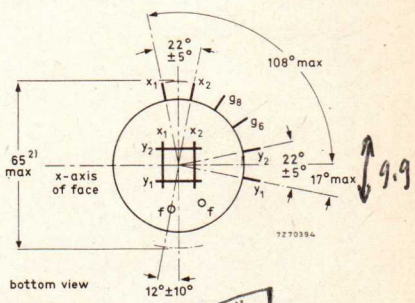
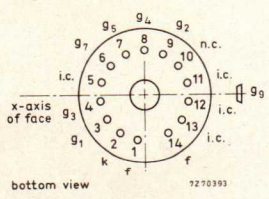
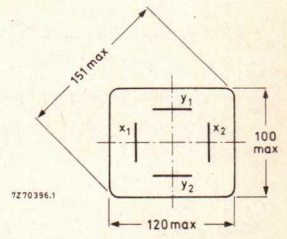
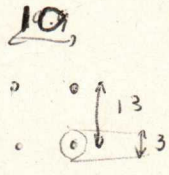
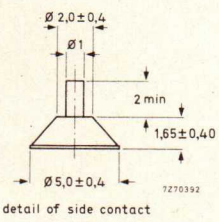
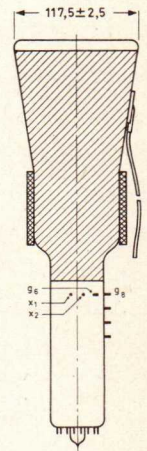
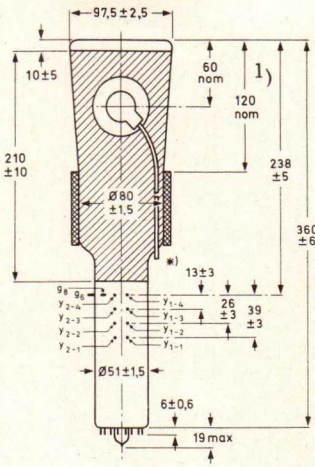
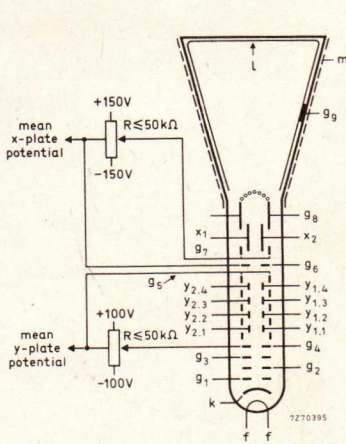

- 1) Recommended position of correction coils.
- 2) See page 2.
- *) Length of cable approx. 460 mm.

g11 = x / 25.5
25.5

TYPICAL OPERATION

Conditions

Final accelerator voltage	$V_{g9(\ell)}$	20	kV
Post deflection accelerator mesh electrode voltage	V_{g8}	2000	V
Geometry control electrode voltage	V_{g7}	2000 ± 150	V 1)
Interplate shield voltage	V_{g6}	2000	V 2)
Deflection plate shield voltage	V_{g5}	2000	V 3)
Astigmatism control electrode voltage	V_{g4}	2000 ± 100	V 4)
Focusing electrode voltage	V_{g3}	500 to 800	V
First accelerator voltage	V_{g2}	2000	V
Control grid voltage for visual extinction of focused spot	V_{g1}	-55 to -110	V
Voltage on outer conductive coating	V_m	2000	V

Performance

Useful scan, horizontal		>	100	mm 5)	
	vertical	>	80	mm	
Deflection coefficient, horizontal	M_x		9	V/cm	
		<	9,9	V/cm	
	vertical	M_y		3	V/cm
			<	3,3	V/cm
Line width		\approx	0,45	mm 6)	
Writing speed		>	1,5	cm/ns ⁷⁾	
Deviation of linearity of deflection			see note 8	%	
Geometry distortion			see note 9		
Grid drive for 10 μ A screen current		\approx	20	V	

- 1) The geometry control electrode voltage V_{g7} should be adjusted within the indicated range (values with respect to the mean x-plate potential).
- 2) The interplate shield voltage should be equal to the mean x-plate potential.
- 3) The deflection plate shield voltage should be equal to the mean y-plate potential. The mean x-plate and y-plate potentials should be equal for optimum performance.
- 4) The astigmatism control electrode voltage should be adjusted for optimum spot shape. For any necessary adjustment its potential will be within the stated range.
- 5) If the tube is operated at a ratio $V_{g9(\ell)}/V_{g5} < 10$, the useful scan may be smaller than 100 mm x 80 mm. The scanned raster can be shifted and aligned with the internal graticule by means of correction coils fitted around the tube.

LIMITING VALUES (Absolute max. rating system)

Final accelerator voltage	$V_{g9(l)}$	max.	21	kV
		min.	15	kV
Post deflection acceleration mesh electrode voltage	V_{g8}	max.	2200	V
Geometry control electrode voltage	V_{g7}	max.	2400	V
Interplate shield voltage	V_{g6}	max.	2200	V
Deflection plate shield voltage	V_{g5}	max.	2200	V
Asigmatism control electrode voltage	V_{g4}	max.	2300	V
		min.	1800	V
Focusing electrode voltage	V_{g3}	max.	2200	V
First accelerator voltage	V_{g2}	max.	2200	V
		min.	1900	V
Control grid voltage	$-V_{g1}$	max.	200	V
		min.	0	V
Cathode to heater voltage, positive	V_{kf}	max.	125	V
negative	$-V_{kf}$	max.	125	V
Voltage between astigmatism control electrode and any deflection plate	$V_{g4/x}$	max.	500	V
	$V_{g4/y}$	max.	500	V
Grid drive, average		max.	30	V
Screen dissipation	W_l	max.	8	mW/cm ²
Ratio V_{g9}/V_{g5}	V_{g9}/V_{g5}	max.	10	
		min.	8	

- 6) Measured with the shrinking raster method in the centre of the screen, with corrections adjusted for optimum spot size, at a beam current of 10 μ A.
- 7) Writing speed measuring conditions:
- | | |
|-----------------------|---------------------------|
| Film | Polaroid 410 (10 000 ASA) |
| Lens | F 1/1, 2 |
| Object to image ratio | 1/0, 5 |
| Modulation | $\Delta V_{g1} = 55$ V |
- 8) The deflection coefficient over each division will not differ more than 5% from that over any other division; all these deflection coefficients being measured per division along the axes.
- 9) A graticule, consisting of concentric rectangles of 95 mm x 75 mm and 93 mm x 73,6 mm is aligned with the electrical x- axis of the tube. With optimum corrections applied, the edges of a raster will fall between these rectangles.

CORRECTION COILS

On request a correction coil unit can be made available consisting of:

1. a pair of coils L1 and L2 which enable the angle between the x and y traces at the centre of the screen to be made exactly 90° (orthogonality correction).
2. a pair of coils L3 and L4 which enable the scanned area to be shifted up and down (vertical shift).
3. a coil L5 for image rotation which enables the alignment of the x trace with the x lines of the graticule.

Orthogonality (coils L1 and L2)

The current required under typical operating conditions with mu-metal shield being used is < 8 mA for complete correction of orthogonality.

The resistance of each coil is $\approx 160 \Omega$.

Shift (coils L3 and L4)

The current required under typical operating conditions with mu-metal shield being used is < 12 mA for a maximum shift of 5 mm.

The resistance of each coil is $\approx 160 \Omega$.

Image rotation (coil L5)

The image rotation coil is wound concentrically around the tube neck. Under typical operating conditions 27 ampere-turns are required for the maximum rotation of 5° .

The coil has 1560 turns. This means that a current of < 18 mA is required.

The resistance of the coil is $\approx 185 \Omega$.

INSTRUMENT CATHODE-RAY TUBE

14 cm diagonal rectangular flat-faced monoaccelerator oscilloscope tube primarily intended for use in inexpensive oscilloscopes and read-out devices.

QUICK REFERENCE DATA

Accelerator voltage	$V_{g2, g4, g5(l)}$	2000	V
Display area		100 x 80	mm^2
Deflection coefficient, horizontal vertical	M_x	23	V/cm
	M_y	13,5	V/cm

SCREEN

	colour	persistence
D14-250GH	green	medium short

Useful screen dimensions $\geq 100 \times 80$ mm

Useful scan, horizontal ≥ 100 mm

vertical ≥ 80 mm

Spot ecc.
HEATING < 7 mm.

Indirect by a. c or d. c. ; parallel supply

Heater voltage V_f 6,3 V

Heater current I_f 300 mA

MECHANICAL DATA

Mounting position: any

The tube should not be supported by the base alone and under no circumstances should the socket be allowed to support the tube.

Dimensions and connections

See also outline drawing

Overall length (socket included) ≤ 333 mm

Face dimensions $\leq 121 \times 100$ mm

Net mass ≈ 1000 g

Base 14-pin all glass

Data based on pre-production tubes.

Accessories

Socket (supplied with tube)	type	55566
Mu-metal shield	type	

FOCUSING

electrostatic

DEFLECTION

double electrostatic

x-plates

symmetrical

y-plates

symmetrical

If use is made of the full deflection capabilities of the tube the deflection plates will block part of the electron beam; hence a low impedance deflection plate drive is desirable.

Angle between x and y traces 90° ± 1°

Angle between x-trace and horizontal axis of the face see note 1)

CAPACITANCES

x ₁ to all other elements except x ₂	C _{x1(x2)}	4.5	4,5	pF
x ₂ to all other elements except x ₁	C _{x2(x1)}	4.3	4,5	pF
y ₁ to all other elements except y ₂	C _{y1(y2)}	3.4	3,5	pF
y ₂ to all other elements except y ₁	C _{y2(y1)}	2.9	3	pF
x ₁ to x ₂	C _{x1x2}	2.1	2	pF
y ₁ to y ₂	C _{y1y2}	1.2	1,1	pF
Control grid to all other elements	C _{g1}	5.8	6	pF
Cathode to all other elements	C _k	4.7	5	pF

2.5

vom D14-217

1) The tube is provided with a rotation coil, concentrically wound around the tube neck, enabling the alignment of the x-trace with the mechanical x-axis of the screen. The coil has 1000 turns and a resistance of 400 Ω . Under typical operating conditions, max. 30 ampere turns are required for the max. rotation of 5°. This means the required current is max. 30 mA at a required voltage of 12 V.

DIMENSIONS AND CONNECTIONS

Dimensions in mm

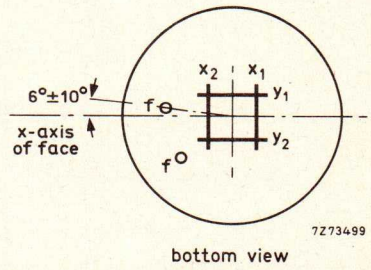
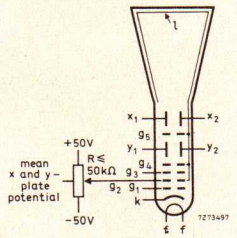
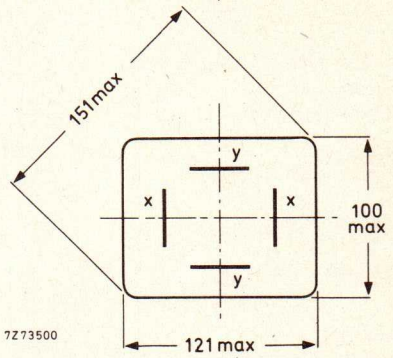
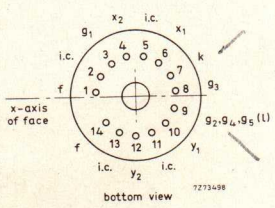
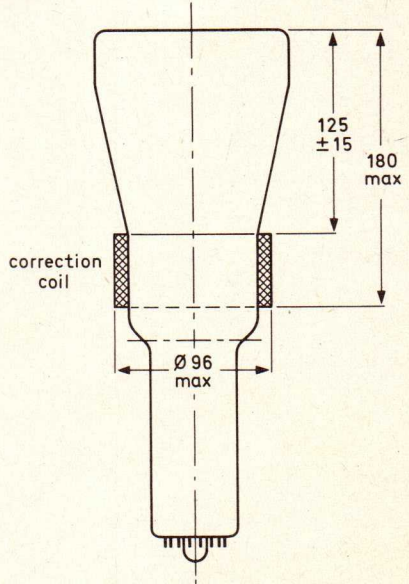
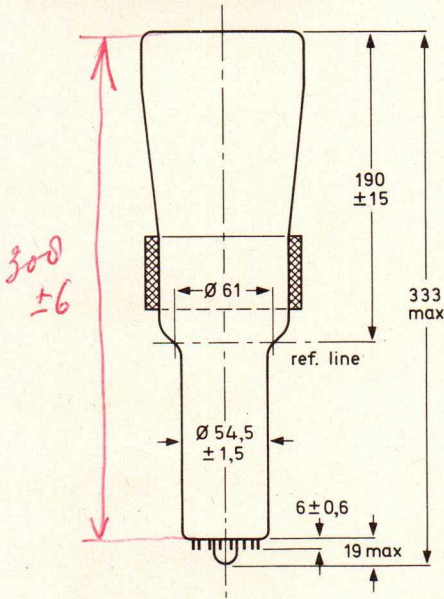

TYPICAL OPERATION

Conditions	1)			
Accelerator voltage		$V_{g2, g4, g5(l)}$	2000	V
Astigmatism control voltage		$\Delta V_{g2, g4, g5(l)}$	± 50	V 2)
Focusing electrode voltage		V_{g3}	220 to 370	V
Control grid voltage for visual extinction of focused spot		V_{g1}	≤ -65	V

Performance

Useful scan, horizontal		\geq	100	mm
vertical		\geq	80	mm
Deflection coefficient, horizontal	M_x		23	V/cm
		$<$	25	V/cm
vertical	M_y		13,5	V/cm
		$<$	14,5 15	V/cm
Line width	l. w.	\approx	0,35	mm 3)
Deviation of linearity of deflection		\leq	2	% 4)
Geometry distortion			see note 5	
Grid drive for 10 μ A screen current		\approx	10	V

LIMITING VALUES (Absolute max. rating system)

Accelerator voltage	$V_{g2, g4, g5(l)}$	max.	2200	V
		min.	1500	V
Focusing electrode voltage	V_{g3}	max.	2200	V
Control grid voltage	$-V_{g1}$	max.	200	V
		min.	0	V
Cathode to heater voltage, positive	V_{kf}	max.	125	V
negative	$-V_{kf}$	max.	125	V
Grid drive, average		max.	20	V
Screen dissipation	W_f	max.	3	mW/cm ²

Notes see page 5.

NOTES

- 1) The mean x-plate potential and the mean y-plate potential should be equal to $V_{g2}, g4, g5(\ell)$ (with astigmatism control voltage set to zero).
- 2) When putting the tube into operation the astigmatism control voltage should be adjusted only once for optimum spot size in the centre of the screen. The control voltage will be within the stated range, provided the conditions of note 1 are adhered to.
- 3) Measured with the shrinking raster method in the centre of the screen. under typical operating conditions, adjusted for optimum spot size at a beam current $I_{\ell} = 10 \mu\text{A}$.
 As the construction of the tube does not permit a direct measurement of the beam current, this current should be determined as follows:
 - a) under typical operating conditions, apply a small raster display (no overscan), adjust V_{g1} for a beam current of approx. $10 \mu\text{A}$ and adjust V_{g3} and $V_{g2}, g4, g5(\ell)$ for optimum spot quality at the centre of the screen.
 - b) under these conditions, but without raster, the deflection plate voltages should be changed to: $V_{y1} = V_{y2} = 2000 \text{ V}$; $V_{x1} = 1300 \text{ V}$; $V_{x2} = 1700 \text{ V}$, thus directing the total beam current to x_2 .
 Measure the current on x_2 and adjust V_{g1} for $I_{x2} = 10 \mu\text{A}$.
 - c) set again for the conditions under a), without touching the V_{g1} control.
 The screen current of the resulting raster display is now $10 \mu\text{A}$.
 - d) focus optimally in the centre of the screen (do not adjust the astigmatism control) and measure the line width.
- 4) The sensitivity at a deflection of less than 75% of the useful scan will not differ from the sensitivity at a deflection of 25% of the useful scan by more than the indicated value.
- 5) A graticule consisting of concentric rectangles of 95 mm x 75 mm and 93 mm x 73 mm is aligned with the electrical x-axis of the tube. With optimum correction potentials applied a raster will fall between these rectangles.

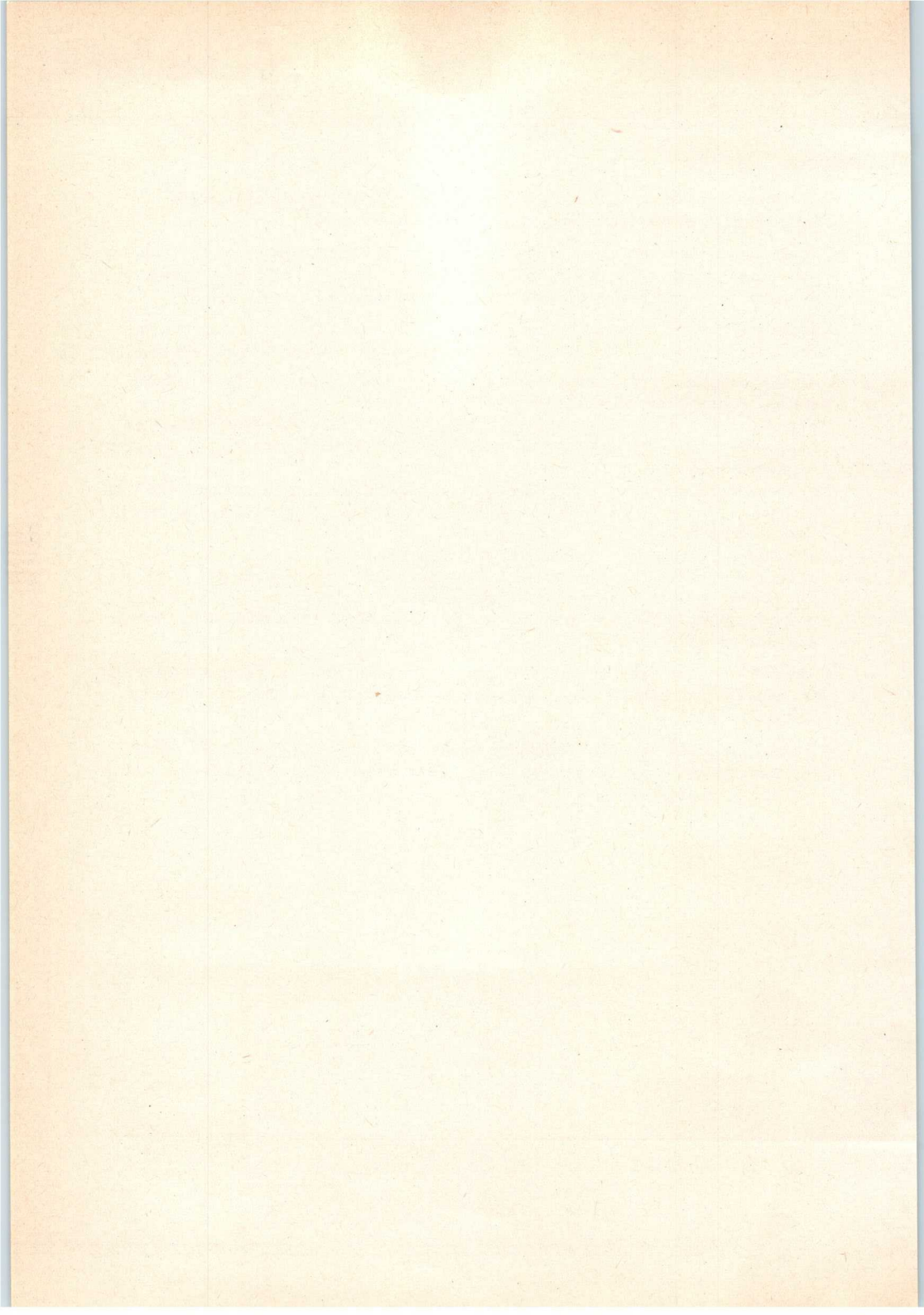

INSTRUMENT CATHODE-RAY TUBE

14 cm diagonal rectangular flat-faced monoaccelerator oscilloscope tube primarily intended for use in inexpensive oscilloscopes and read-out devices.
This tube features a low heater power consumption.

QUICK REFERENCE DATA

Accelerator voltage	$V_{g2, g4, g5(\ell)}$	2000	V
Display area		100 x 80	mm^2
Deflection coefficient, horizontal vertical	M_x	23	V/cm
	M_y	13,5	V/cm

The D14-251GH is equivalent to the type D14-250GH except for the following:

HEATING

Indirect by a.c. or d.c. ; parallel supply

Heater voltage	V_f	6,3	V
Heater current	I_f	95	mA

LIMITING VALUES (Absolute max. rating system)

Cathode to heater voltage, positive	V_{kf} max.	100	V
negative	$-V_{kf}$ max.	15	V

Data based on pre-production tubes.

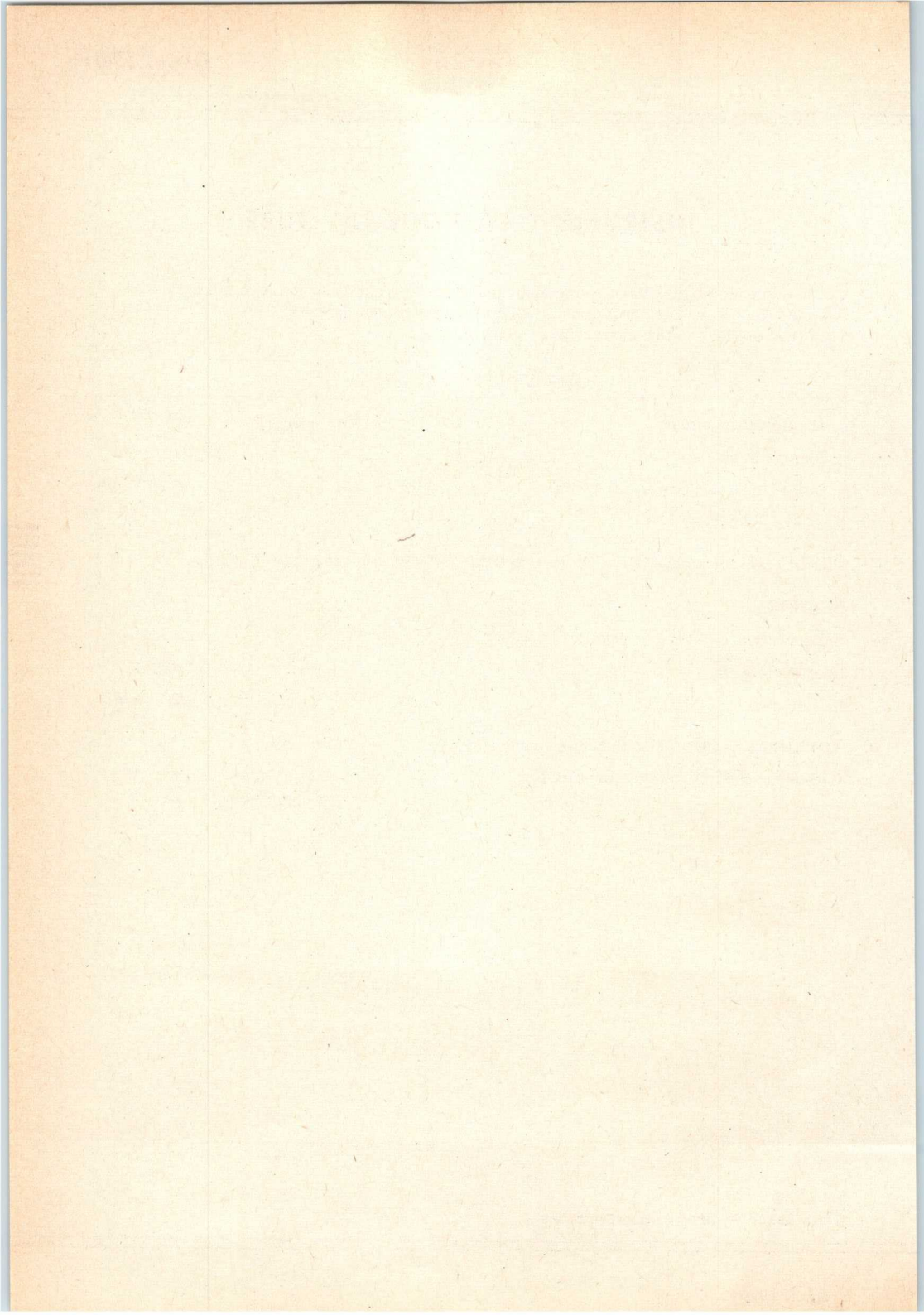

INSTRUMENT CATHODE-RAY TUBE

18 cm diagonal, rectangular flat faced oscilloscope tube with mesh and metal backed screen.

QUICK REFERENCE DATA

Final accelerator voltage	$V_{g7(\ell)}$	10	kV
Display area		120 x 100	mm ²
Deflection factor, horizontal	M_x	15,5	V/cm
vertical	M_y	4,5	V/cm

SCREEN : Metal backed phosphor

	colour	persistence
D18-120GH	green	medium short

Useful screen area	min.	120 x 100	mm ²
Useful scan at $V_{g7(\ell)}/V_{g2', g4} = 5$			
horizontal	min.	120	mm
vertical	min.	100	mm
Spot eccentricity in horizontal direction		± 8	mm
in vertical direction		± 6	mm

HEATING : Indirect by a.c. or d.c.; parallel supply

Heater voltage	V_f	6,3	V
Heater current	I_f	300	mA

MECHANICAL DATA

* The centre of the contact is located within a square of 10 mm x 10 mm around the true geometrical position.

Dimensions in mm

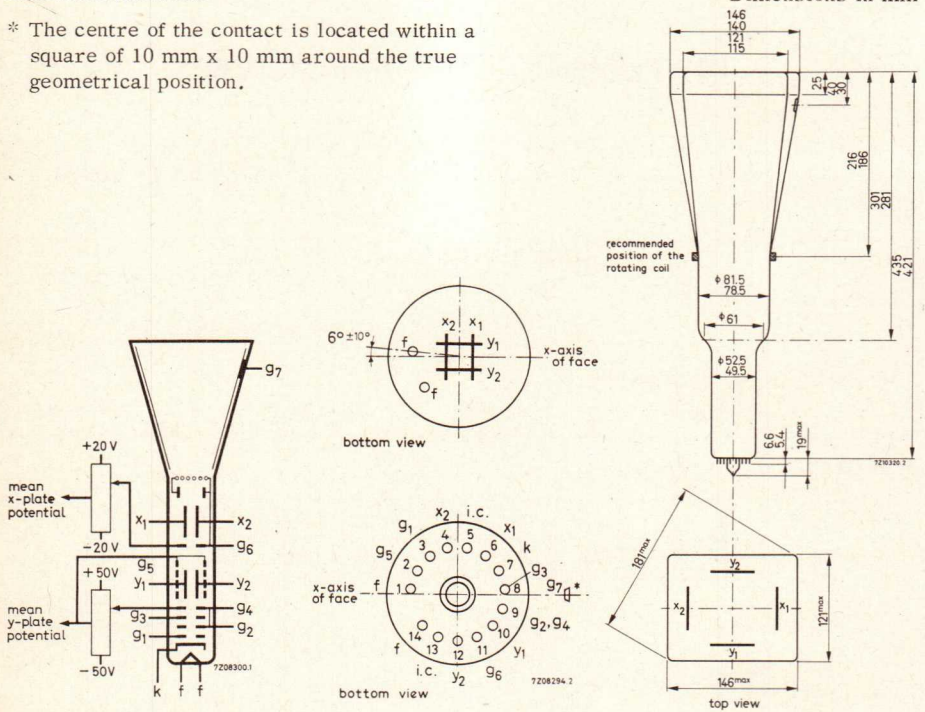

Mounting position: any

The tube should not be supported by the base alone and under no circumstances should the socket be allowed to support the tube.

Dimensions and connections

See also outline drawing

Overall length (socket included) max. 454 mm

Face dimensions max. 146 x 121 mm²

Net weight approx. 1300 g

Base 14 pin all glass

Accessories

Socket (supplied with tube) type 55566

Final accelerator contact connector type 55563A

Mu-metal shield type 55584

TYPICAL OPERATING CONDITIONS

Final accelerator voltage	$V_{g7(\ell)}$	10000	V
Interplate shield voltage	V_{g6}	2000	V
Geometry control voltage	ΔV_{g6}	± 20	V ²⁾
Deflection plate shield voltage	V_{g5}	2000	V ³⁾
Focusing electrode voltage	V_{g3}	350 to 500	V
First accelerator voltage	$V_{g2, g4}$	2000	V
Astigmatism control voltage	$\Delta V_{g2, g4}$	± 50	V ⁴⁾
Control grid voltage for visual extinction of focused spot	V_{g1}	-25 to -80	V
Grid drive for 10 μ A screen current		approx. 12	V
Deflection factor, horizontal	M_x	av.	15,5 V/cm
		max.	17 V/cm
vertical	M_y	av.	4,5 V/cm
		max.	5 V/cm
Deviation of linearity of deflection		max.	2 % ⁵⁾
Geometry distortion		See note 6	
Useful scan, horizontal		min.	120 mm
		min.	100 mm
vertical		min.	100 mm

LIMITING VALUES (Absolute max. rating system)

Final accelerator voltage	$V_{g7(\ell)}$	max.	11000	V
		min.	9000	V
Interplate shield voltage and geometry control electrode voltage	V_{g6}	max.	2200	V
		max.	2200	V
Deflection plate shield voltage	V_{g5}	max.	2200	V
Focusing electrode voltage	V_{g3}	max.	2200	V
First accelerator and astigmatism control electrode voltage	$V_{g2, g4}$	max.	2200	V
		min.	1350	V
Control grid voltage	$-V_{g1}$	max.	200	V
		min.	0	V
Cathode to heater voltage	V_{kf}	max.	125	V
		min.	125	V
Voltage between astigmatism control electrode and any deflection plate	$V_{g4/x}$	max.	500	V
		max.	500	V
Grid drive, average	$V_{g4/y}$	max.	20	V
		max.	8	mW/cm ²
Screen dissipation	W_{ℓ}	max.	8	mW/cm ²
Ratio $V_{g7(\ell)}/V_{g2, g4}$	$V_{g7(\ell)}/V_{g2, g4}$	max.	6,7	

Notes see page 5.

NOTES

- 1) In order to align the x-trace with the horizontal axis of the screen, the whole picture can be rotated by means of a rotation coil. This coil will have 50 amp. turns for the indicated max. rotation of 5° and should be positioned as indicated in the drawing.
- 2) This tube is designed for optimum performance when operating at a ratio $V_{g7}/V_{g2, g4} = 5$.
The geometry electrode voltage should be adjusted within the indicated range (values with respect to the mean x-plate potential).
A negative control voltage will cause some pincushion distortion and less background light, a positive control voltage will give some barrel distortion and a slight increase of background light.
- 3) The deflection plate shield voltage should be equal to the mean y-plate potential. The mean x- and y-plate potentials should be equal for optimum spot quality.
- 4) The astigmatism control electrode voltage should be adjusted for optimum spot shape. For any necessary adjustment its potential will be within the stated range.
- 5) The sensitivity at a deflection of less than 75% of the useful scan will not differ from the sensitivity at a deflection of 25% of the useful scan by more than the indicated value.
- 6) A graticule, consisting of concentric rectangles of 115 mm x 95 mm and 112,2 mm x 93,0 mm is aligned with the electrical x-axis of the tube, with optimum correction potentials applied, a raster will fall between these rectangles.

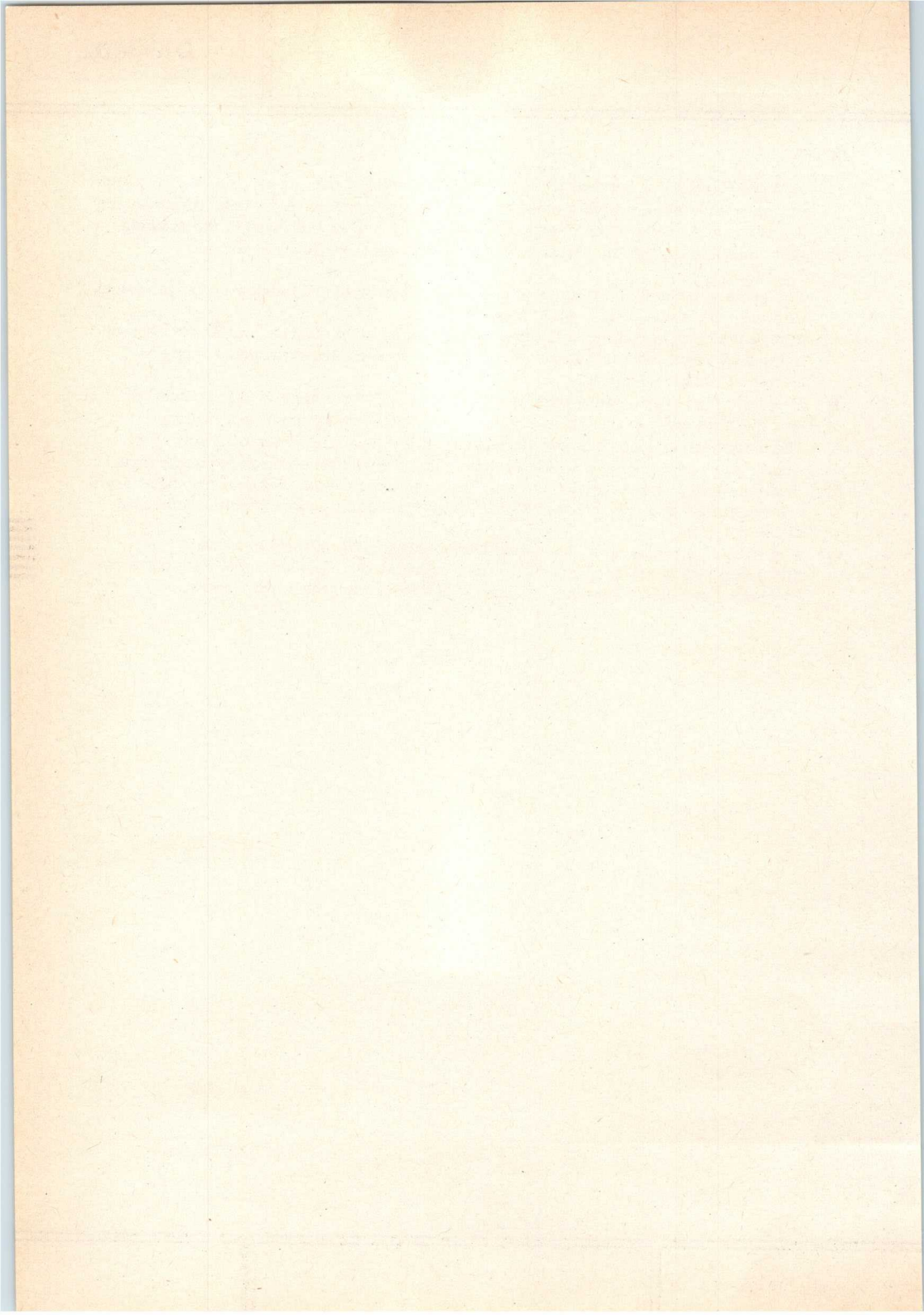

INSTRUMENT CATHODE-RAY TUBE

Cathode-ray tube for monitoring purposes.

QUICK REFERENCE DATA

Accelerator voltage	$V_{g3}(\ell)$	800 V
Display area	Both directions full scan	
Deflection coefficient, horizontal vertical	M_x	62,5 V/cm
	M_y	40 V/cm

SCREEN

	colour	persistence
DG7-5	yellowish green	medium short

Useful screen diameter > 65 mm

Useful scan

horizontal	full scan
vertical	full scan

HEATING

Indirect by a. c. or d. c. ; parallel supply

Heater voltage	V_f	6,3 V
Heater current	I_f	300 mA

MECHANICAL DATA

Dimensions in mm

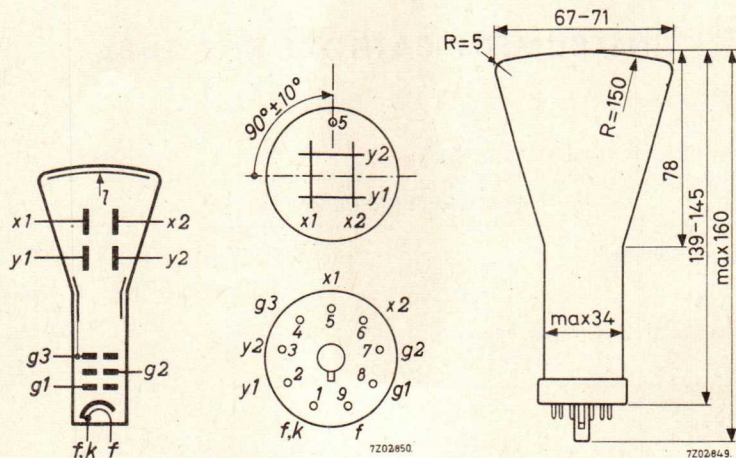

Mounting position:

The tube should not be supported by the base alone and under no circumstances should the socket be allowed to support the tube.

Base English Octal 9-pin

Dimensions and connections

See also outline drawing

Overall length	<	160	mm
Face diameter	<	71	mm
<u>Net mass:</u>		approx.	140 g

Accessories

Mu-metal shield type 55530

LIMITING VALUES (Absolute max. rating system)

Accelerator voltage	$V_{g3} (\ell)$	max. 1000 V min. 800 V
Focusing electrode voltage	V_{g2}	max. 400 V
Control grid voltage		
negative	$-V_{g1}$	max. 200 V
positive	V_{g1}	max. 0 V
positive peak	V_{g1p}	max. 2 V
Cathode to heater voltage		
cathode positive	$V+k/f-$	max. 200 V
cathode negative	$V-k/f+$	max. 125 V
Voltage between accelerator electrode and any deflection plate	$V_{g3/x}$ $V_{g3/y}$	max. 500 V max. 500 V
Screen dissipation	W_{ℓ}	max. 3 mW/cm ²

CIRCUIT DESIGN VALUES

Focusing voltage	V_{g2}	250 to 375 V per kV of V_{g3}
Control grid voltage for visual extinction of focused spot	$-V_{g1}$	0 to 62, 5 V per kV of V_{g3}
Deflection coefficient		
horizontal	M_x	66 to 90 V/cm per kV of V_{g3}
vertical	M_y	41 to 56 V/cm per kV of V_{g3}
Control grid circuit resistance	R_{g1}	max. 0, 5 M Ω
Deflection plate circuit resistance	R_x, R_y	max. 5 M Ω

¹) A graticule, consisting of concentric rectangles of 43.2 mm x 43.2 mm and 40 mm x 40 mm is aligned with the electrical x axis of the tube. The edges of a raster will fall between these rectangles with optimum correction potentials applied.

INSTRUMENT CATHODE -RAY TUBE

Cathode-ray tube for monitoring purposes.

QUICK REFERENCE DATA

Accelerator voltage	$V_{g3(t)}$	800	V
Display area	Both directions full scan		
Deflection coefficient, horizontal	M_x	62,5	V/cm
vertical	M_y	40	V/cm

SCREEN

	Colour	Persistence
DG7-6	yellowish green	medium short

Useful screen diameter	>	65	mm
Useful scan, horizontal	full scan		
vertical	full scan		

HEATING : Indirect by a.c. or d.c. ; parallel supply

Heater voltage	V_f	6,3	V
Heater current	I_f	300	mA

MECHANICAL DATADimensions and connections

See also outline drawing

Overall length	<	160	mm
Face diameter	<	71	mm
<u>Net mass</u>	approx.	140	g

Accessories

Mu-metal shield	type	55530
-----------------	------	-------

Dimensions in mm

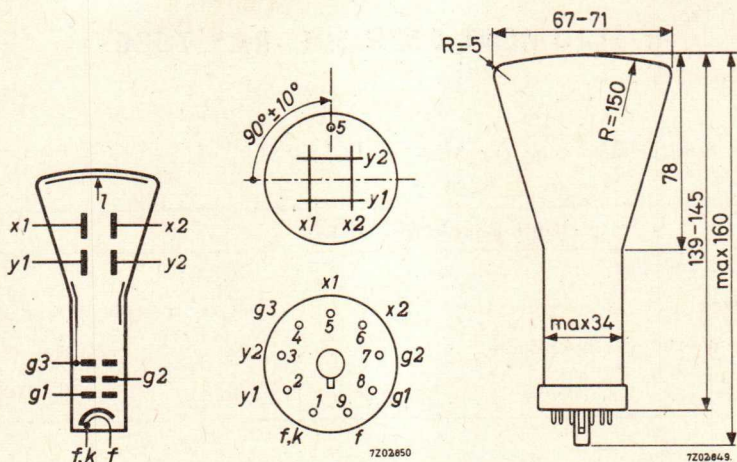

Mounting position: any

The tube should not be supported by the base alone and under no circumstances should the socket be allowed to support the tube.

Base English loctal 9-pin

CAPACITANCES

x1 to all other elements except x2	$C_{x1(x2)}$	2,8	pF
x2 to all other elements except x1	$C_{x2(x1)}$	2,8	pF
y1 to all other elements except y2	$C_{y1(y2)}$	3,0	pF
y2 to all other elements except y1	$C_{y2(y1)}$	3,3	pF
x1 to x2	C_{x1x2}	0,8	pF
y1 to y2	C_{y1y2}	0,6	pF
Control grid to all other elements	C_{g1}	7,0	pF
Cathode to all other elements	C_k	3,2	pF

FOCUSING electrostatic

DEFLECTION double electrostatic

x plates asymmetrical
 x_1 has to be connected to the accelerator electrode.
 Earthing of the accelerator electrode is recommended.

y plates symmetrical

Angle between x and y traces $90^\circ \pm 1,5^\circ$

LINE WIDTH

Measured on a circle of 50 mm diameter

Accelerator voltage	$V_{g3(l)}$	800	V
Beam current	I_l	0,5	μA
Line width	l. w.	0,4	mm

TYPICAL OPERATING CONDITIONS

Accelerator voltage	$V_{g3(l)}$	800	V
Focusing electrode voltage	V_{g2}	200 to 300	V
Control grid voltage for visual extinction of focused spot	V_{g1}	< -50	V
Deflection coefficient, horizontal	M_x	53 to 72	V/cm
vertical	M_y	33 to 45	V/cm
Geometry distortion		see note 1	
Useful scan, horizontal		full scan	
vertical		full scan	

¹⁾ A graticule consisting of concentric rectangles of 43,2 mm x 43,2 mm and 40 mm x 40 mm is aligned with the electrical x axis of the tube. The edges of a raster will fall between these rectangles with optimum correction potentials applied.

INSTRUMENT CATHODE-RAY TUBE

Low accelerator voltage cathode-ray tube with asymmetrical deflection, intended for monitoring purposes.

QUICK REFERENCE DATA			
Final accelerator voltage	$V_{g4g2(\ell)}$	500	V
Display area	Both directions full scan		
Deflection coefficient, horizontal	M_x	37	V/cm
	vertical	M_y	21 V/cm

SCREEN

	Colour	Persistence
DG7-31	yellowish green	medium short

Useful diameter > 65 mm
 Useful scan, horizontal full scan
 vertical full scan

HEATING

Indirect by a.c. or d.c.; parallel supply

Heater voltage V_f 6,3 V
 Heater current I_f 300 mA

MECHANICAL DATA

Dimensions in mm

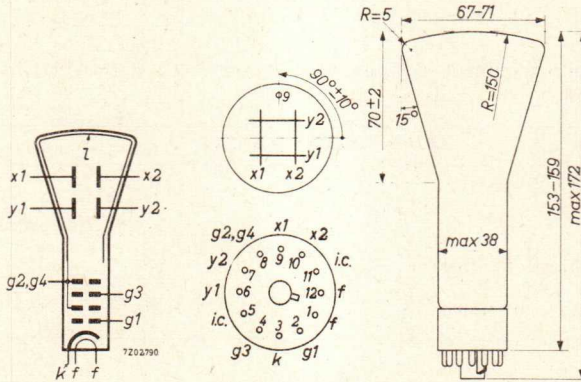

Mounting position: any

The tube should not be supported by the base alone and under no circumstances should the socket be allowed to support the tube.

Base Duodecal 12 pin

Dimensions and connections

See also outline drawing

Overall length < 172 mm

Face diameter < 71 mm

Net mass approx. 120 g

Accessories

Mu-metal shield type 55530

LIMITING VALUES (Absolute max. rating system)

Accelerator voltage	$V_{g4g2(l)}$	max.	800	V
		min.	400	V
Focusing electrode voltage	V_{g3}	max.	200	V
Control grid voltage, negative	$-V_{g1}$	max.	200	V
		positive	V_{g1}	max. 0 V
		positive peak	V_{g1p}	max. 2 V
Cathode to heater voltage, positive	V_{kf}	max.	200	V
		negative	$-V_{kf}$	max. 125 V
Voltage between accelerator electrode and any deflection plate	$V_{g4/x}$	max.	500	V
		$V_{g4/y}$	max.	500 V
		Screen dissipation	W_l	max. 3

CIRCUIT DESIGN VALUES

Control grid circuit resistance	R_{g1}	max.	0,5	MΩ
Deflection plate circuit resistance	R_x, R_y	max.	5	MΩ
Focusing electrode current	I_{g3}	-15 to +10	μA ²⁾	

1) A graticule, consisting of concentric rectangles of 43,2 mm x 43,2 mm and 40 mm x 40 mm is aligned with the electrical x-axis of the tube. The edges of a raster will fall between these rectangles with optimum correction potentials applied.

2) Values to be taken into account for the calculation of the focus potentiometer.

Remark: A contrast improving transparent conductive coating connected to $g4g2(l)$ is present between glass and fluorescent layer. This enables the application of a high potential to $g4g2(l)$ with respect to earth, without the risk of picture distortion by touching the face (electrostatic body-effect).

INSTRUMENT CATHODE-RAY TUBE

Low accelerator voltage cathode-ray tube with symmetrical deflection, intended for monitoring purposes.

QUICK REFERENCE DATA

Final accelerator voltage	$V_{g4g2(\ell)}$	500	V
Display area	Both directions full scan		
Deflection coefficient, horizontal	M_x	37	V/cm
vertical	M_y	21	V/cm

SCREEN

	Colour	Persistence
DG7-32	yellowish green	medium short

Useful diameter	> 65	mm
Useful scan, horizontal	full scan	
vertical	full scan	

HEATING

Indirect by a. c. or d. c. : parallel supply

Heater voltage	V_f	6,3	V
Heater current	I_f	300	mA

MECHANICAL DATA

Dimensions in mm

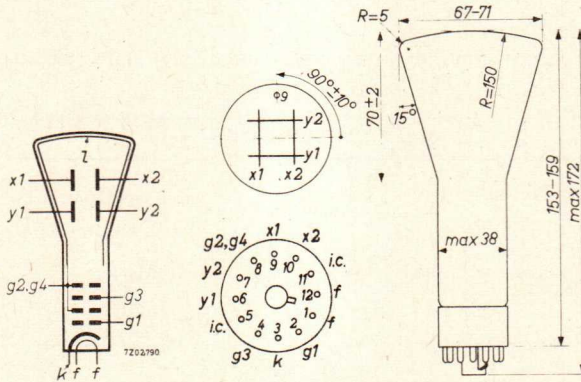

Mounting position: any

The tube should not be supported by the base alone and under no circumstances should the socket be allowed to support the tube.

Base Duodecal 12 pin

Dimensions and connections

See also outline drawing

Overall length < 172 mm

Face diameter < 71 mm

Net mass approx. 120 g

Accessories

Mu-metal shield type 55530

INSTRUMENT CATHODE-RAY TUBE

Low accelerator voltage cathode-ray tube for monitoring purpose

QUICK REFERENCE DATA

Accelerator voltage	$V_{g4, g2, y2}(\ell)$ 500 V
Display area	Both directions full scan
Deflection coefficient, horizontal	M_x 56,5 V/cm
vertical	M_y 49 V/cm

SCREEN

	Colour	Persistence
DH3-91	green	medium short

Useful screen diameter min. 28 mm

Useful scan

horizontal full scan

vertical full scan

HEATING

Indirect by a. c. or d. c. ; parallel supply

Heater voltage V_f 6,3 V

Heater current I_f 300 mA

MECHANICAL DATA

Dimensions in mm

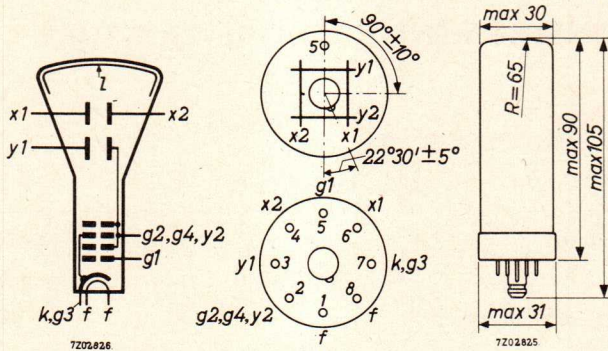

Mounting position: any

The tube should not be supported by the base alone and under no circumstances should the socket be allowed to support the tube.

Base: English Loctal 8-pin

Dimensions and connections

See also outline drawing

Overall length < 105 mm

Face diameter < 30 mm

Net mass: approx. 39 g

Accessories

Mu-metal shield type 55525

CAPACITANCES

x_1 to all other elements except x_2	$C_{x_1(x_2)}$	4,5 pF
x_2 to all other elements except x_1	$C_{x_2(x_1)}$	4,5 pF
y_1 to all other elements except y_2	$C_{y_1(y_2)}$	3,5 pF
x_1 to x_2	$C_{x_1x_2}$	1,0 pF
Control grid to all other elements	C_{g_1}	5,6 pF

FOCUSING electrostatic self focusing

DEFLECTION double electrostatic

x plates	symmetrical
y plates	asymmetrical

LINE WIDTH

Measured on a circle of 25 mm diameter

Accelerator voltage	$V_{g_4, g_2, y_2(\ell)}$	500 V
Beam current	$I(\ell)$	0,5 μ A
Line width	l.w.	0,6 mm

TYPICAL OPERATING CONDITIONS

Accelerator voltage	$V_{g_4, g_2, y_2(\ell)}$	500 V
Control grid voltage for visual extinction of focused spot	$-V_{g_1}$	8 to 27 V
Deflection coefficient		
horizontal	M_x	41 to 72 V/cm
vertical	M_y	35 to 63 V/cm
Useful scan		
horizontal		full scan
vertical		full scan

LIMITING VALUES (Absolute max. rating system)

Accelerator voltage	$V_{g_4, g_2, y_2}(\ell)$	max. 1000 V min. 350 V
Control grid voltage		
negative	$-V_{g_1}$	max. 200 V
positive	V_{g_1}	max. 0 V
positive peak	$V_{g_{1p}}$	max. 2 V
Cathode to heater voltage		
cathode positive	$V_{+k/f-}$	max. 200 V
cathode negative	$V_{-k/f+}$	max. 125 V
Screen dissipation	W_ℓ	max. 3 mW/cm ²

CIRCUIT DESIGN VALUES

Control grid voltage for visual extinction of focused spot	$-V_{g_1}$	16 to 54 V per kV of V_{g_4, g_2, y_2}
Deflection coefficient		
horizontal	M_x	90 to 120 V/cm per kV of V_{g_4, g_2, y_2}
vertical	M_y	38, 5 to 52, 5 V/cm per kV of V_{g_4, g_2, y_2}
Control grid circuit		
resistance	R_{g_1}	max. 1 M Ω
Deflection plate circuit		
resistance	R_x, R_y	max. 5 M Ω

REMARK

A contrast improving transparent conductive coating connected to the accelerator electrode is present between glass and fluorescent layer. This enables the application of a high potential with respect to earth to the accelerator electrode, without the risk of picture distortion by touching the face (electrostatic body-effect).

INSTRUMENT CATHODE-RAY TUBE

Oscilloscope tube with 7 cm diameter flat face and post deflection acceleration by means of a helical electrode. The low heater consumption together with the high sensitivity render this tube suitable for transistorized equipment.

QUICK REFERENCE DATA

Final accelerator voltage	$V_{g6(\ell)}$	1200	V
Display area		4,5 x 6	cm ²
Deflection coefficient, horizontal	M_x	10,7	V/cm
vertical	M_y	3,65	V/cm

SCREEN

	Colour	Persistence
DH7-11	green	medium short
DN7-11	bluish green	medium short
DP7-11	yellowish green	long

Useful diameter	>	68	mm
Useful scan at $V_{g6(\ell)}/V_{g4} = 4$, horizontal	>	60	mm
vertical	>	45	mm

HEATING : Indirect by a.c. or d.c.; parallel supply

Heater voltage	V_f	6,3	V
Heater current	I_f	95	mA

MECHANICAL DATA

Dimensions and connections

See also outline drawing

Overall length	<	296	mm
Face diameter	<	77,8	mm
<u>Net mass</u>	approx.	370	g

Dimensions in mm

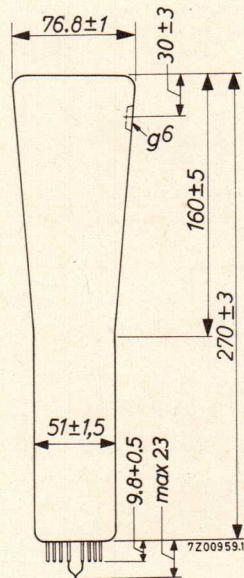
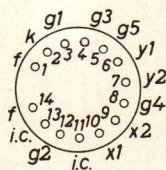
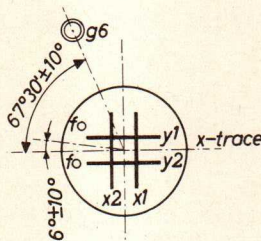
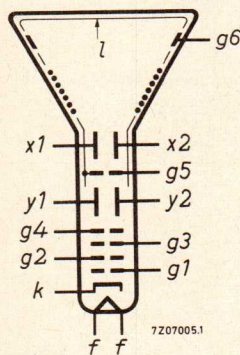

Mounting position: any

The tube should not be supported by the base alone and under no circumstances should the socket be allowed to support the tube.

Base 14 pin all glass

Accessories

Socket (supplied with tube)	type	40467
Final accelerator contact connector	type	55563A
Mu-metal shield	type	55532

CAPACITANCES

x1 to all other elements except x2	$C_{x1(x2)}$	4,0	pF
x2 to all other elements except x1	$C_{x2(x1)}$	4,0	pF
y1 to all other elements except y2	$C_{y1(y2)}$	3,5	pF
y2 to all other elements except y1	$C_{y2(y1)}$	3,5	pF
x1 to x2	C_{x1x2}	1,9	pF
y1 to y2	C_{y1y2}	1,7	pF
Control grid to all other elements	C_{g1}	5,7	pF
Cathode to all other elements	C_k	3,0	pF

CIRCUIT DESIGN VALUES

Focusing voltage	V_{g3}	35 to 165	V per kV of V_{g4}
Control grid voltage for visual extinction of focused spot	V_{g1}	-30 to -60	V per kV of V_{g2}
Deflection coefficient at $V_{g6(\ell)}/V_{g4} = 4$			
horizontal	M_x	31, 3 to 40, 0	V/cm per kV of V_{g4}
vertical	M_y	10, 7 to 13, 7	V/cm per kV of V_{g4}
Control grid circuit resistance	R_{g1}	max. 1, 5	$M\Omega$
Deflection plate circuit resistance	R_x, R_y	max. 50	$k\Omega$
Focusing electrode current	I_{g3}	-15 to +10	μA ⁵⁾

LIMITING VALUES (Absolute max. rating system)

Final accelerator voltage	$V_{g6(\ell)}$	max. 5000 V min. 1200 V
Geometry control electrode voltage	V_{g5}	max. 2200 V
Astigmatism control electrode voltage	V_{g4}	max. 2100 V min. 300 V
Focusing electrode voltage	V_{g3}	max. 1000 V
First accelerator voltage	V_{g2}	max. 1600 V min. 800 V
Control grid voltage, negative	$-V_{g1}$	max. 200 V
positive	V_{g1}	max. 0 V
positive peak	V_{g1p}	max. 2 V
Cathode to heater voltage, positive	V_{kf}	max. 100 V
negative	$-V_{kf}$	max. 15 V
Voltage between astigmatism control electrode and any deflection plate	$V_{g4/x}$ $V_{g4/y}$	max. 500 V max. 500 V
Screen dissipation	W_ℓ	max. 3 W/cm^2
Ratio $V_{g6(\ell)}/V_{g4}$	$V_{g6(\ell)}/V_{g4}$	max. 4

Notes see page 5

NOTES

- 1) This tube is designed for optimum performance when operating at the ratio $V_{g6(l)}/V_{g4} = 4$. Operation at other ratio may result in changes in deflection uniformity and geometry distortion. The geometry control electrode voltage should be adjusted for optimum performance. For any necessary adjustment its potential will be within the stated range.
- 2) The astigmatism control electrode voltage should be adjusted for optimum spot shape. For any necessary adjustment its potential will be within the stated range.
- 3) The sensitivity at a deflection of less than 75% of the useful scan will not differ from the sensitivity of 25% of the useful scan by more than the indicated value.
- 4) A graticule consisting of concentric rectangles of 40,8 mm x 40,8 mm and 39,2 mm x 39,2 mm is aligned with the electrical x axis of the tube. The edges of a raster will fall between these rectangles with optimum correction potentials applied.
- 5) Values to be taken into account for the calculation of the focus potentiometer.

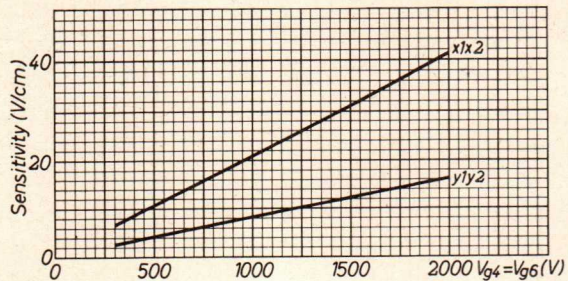
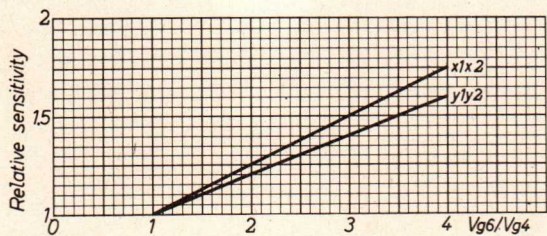
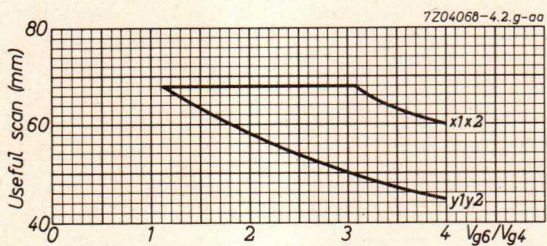

INSTRUMENT CATHODE-RAY TUBE

10 cm diameter flat faced double gun oscilloscope tube, post-deflection acceleration by means of a helical electrode and low interaction between traces. The tube features beam-blanking.

QUICK REFERENCE DATA		
Final accelerator voltage	$V_{g8}(\ell)$	3000 V
Display area	horizontal full scan	
	vertical	7 cm
Deflection coefficient, horizontal	M_x	15 V/cm
	vertical	M_y

SCREEN

	colour	persistence
E10-12GH	green	medium short
E10-12GM	yellowish green	long
E10-12GP	bluish green	medium short

Useful screen diameter min. 85 mm

Useful scan (each gun) at $V_{g8}(\ell)/V_{g5} = 3$

horizontal full scan

vertical min. 70 mm

The useful scan may vertically be shifted to a max. of 5 mm with respect to the geometric centre of the face plate.

HEATING

Indirect by A. C. or D. C.; parallel supply

Heater voltage	each gun	V_f	6.3 V
Heater current		I_f	300 mA

MECHANICAL DATA

Dimensions in mm

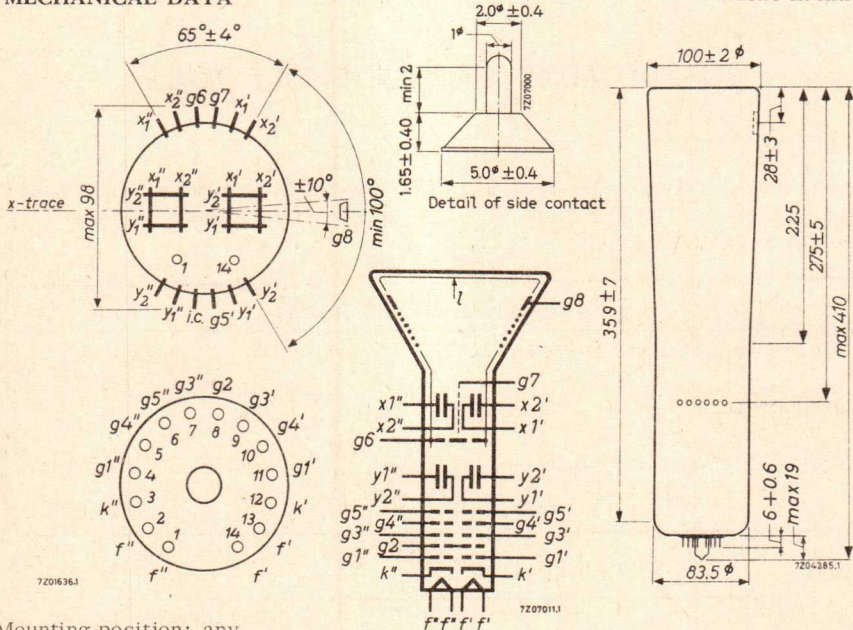

Mounting position: any

The tube should not be supported by the base alone and under no circumstances should the socket be allowed to support the tube.

Base

14 pin all glass

Dimensions and connections

Overall length	max.	410	mm
Face diameter	max.	102	mm

Net weight

approx. 800 g

Accessories

Socket, supplied with tube	type	55566
→ Final accelerator contact connector	type	55563A
Side contact connector	type	55561
Mu-metal shield	type	55545

LIMITING VALUES (each gun, if applicable) (Absolute max. rating system)

Final accelerator voltage	$V_{g8}(\ell)$	max.	3300 V
		min.	2700 V
Intergun shield voltage	V_{g7}	max.	1200 V
Geometry control electrode voltage	V_{g6}	max.	1200 V
Astigmatism control electrode voltage	V_{g5}	max.	1200 V
		min.	800 V
Focusing electrode voltage	V_{g4}	max.	1200 V
Beam blanking electrode voltage	V_{g3}	max.	1200 V
First accelerator voltage	V_{g2}	max.	1200 V
		min.	200 V
Control grid voltage,			
negative	$-V_{g1}$	max.	200 V
positive	V_{g1}	max.	0 V
positive peak	V_{g1p}	max.	2 V
Cathode to heater voltage,			
cathode positive	V_{kf}	max.	200 V
cathode negative	$-V_{kf}$	max.	125 V
Average cathode current	I_k	max.	300 μ A
Screen dissipation	W_ℓ	max.	3 mW/cm ²
Ratio $V_{g8}(\ell)/V_{g5}$	$V_{g8}(\ell)/V_{g5}$	max.	3

CIRCUIT DESIGN VALUES (each gun, if applicable)

Focusing voltage	V_{g4}	180 to 380	V/kV of V_{g2}
Control grid voltage for visual cut-off focused spot	V_{g1}	25 to -90	V/kV of V_{g2}
Deflection coefficient $V_{g8}(\ell)/V_{g5} = 3$			
horizontal	M_x	10 to 20	V/cm per kV of V_{g5}
vertical	M_y	6 to 8	V/cm per kV of V_{g5}
Focusing electrode current	I_{g4}	-15 to +10	μA
Control grid circuit resistance	R_{g1}	max. 1.5	$M\Omega$

- 1) This tube is designed for optimum performance when operating at the ratio $V_{g8}(\ell)/V_{g5} = 3$. Operation at other ratio may result in changes in deflection uniformity and geometry distortion. The geometry control electrode voltage and the intergunshield voltage should be adjusted for optimum performance. For any necessary adjustment its potential will be within the stated range.
- 2) This voltage should be equal to the mean x- and y plates potential.
- 3) The astigmatism control electrode voltage should be adjusted for optimum spot shape. For any necessary adjustment its potential will be within the stated range.
- 4) The sensitivity at a deflection of less than 75% of the useful scan will not differ from the sensitivity at a deflection of 25% of the useful scan by more than the indicated value.
- 5) A graticule consisting of concentric rectangles of 60 mm x 60 mm and 57 mm x 57 mm is aligned with electrical x axis of the tube. The edges of a raster will fall between these rectangles with optimum potentials applied.
- 6) The deflection of one beam when balanced dc voltage are applied to the deflection plates of the other beam, will not be greater than the indicated value.
- 7) With 50 mm vertical traces superimposed at the tube face centre and deflected horizontally ± 4 cm by voltages proportional to the relative deflection factors, horizontal separation of the corresponding points of the traces shall not be greater than the indicated value.

INSTRUMENT CATHODE-RAY TUBE

10 cm diameter metal-backed flat-faced double gun oscilloscope tube with post-deflection acceleration by means of a helical electrode and low interaction between beams.

QUICK REFERENCE DATA

Final accelerator voltage	$V_{g8}(\ell)$	4000 V
Display area	horizontal	full scan
	vertical	7 cm
Deflection coefficient, horizontal	M_x	17 V/cm
	vertical	M_y

SCREEN

	Colour	Persistence
E10-130GH	green	medium short
E10-130GM	yellowish green	long
E10-130GP	bluish green	medium short

Useful screen diameter min. 85 mm

Useful scan (each gun) at $V_{g8}(\ell)/V_{g5} = 4$

horizontal	full scan
vertical	min. 70 mm

The useful scan may be shifted vertically to a maximum of 5 mm with respect to the geometric centre of the face plate.

HEATING

Indirect by A.C. or D.C.; parallel supply

Heater voltage	V_f	6.3 V
Heater current	I_f	300 mA

MECHANICAL DATA

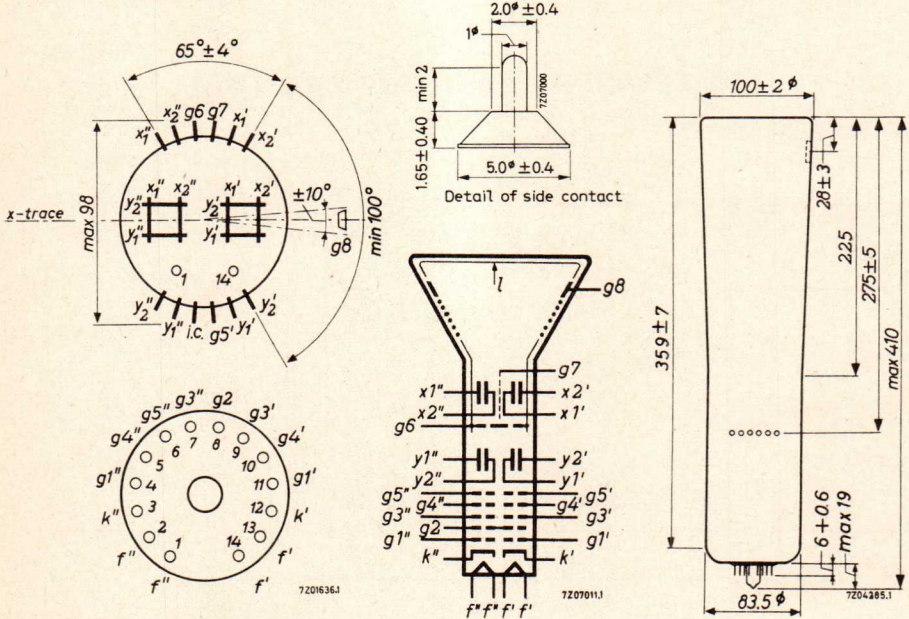

Mounting position: any

The tube should not be supported by the base alone and under no circumstances should the socket be allowed to support the tube.

Base

14 pin, all glass

Dimensions and connections

Overall length max. 410 mm

Face diameter max. 102 mm

Net weight

approx. 800 g

Accessories

Socket, supplied with tube type 55566

Final-accelerator contact connector type 55563A

Side contact connector type 55561

Mu-metal shield type 55545

CAPACITANCES

x_1' to all other elements except x_2'	$C_{x_1'}(x_2')$	4.5 pF
x_2' to all other elements except x_1'	$C_{x_2'}(x_1')$	3 pF
x_1'' to all other elements except x_2''	$C_{x_1''}(x_2'')$	3 pF
x_2'' to all other elements except x_1''	$C_{x_2''}(x_1'')$	4.5 pF
y_1 to all other elements except y_2	$C_{y_1}(y_2)$	2 pF
y_2 to all other elements except y_1	$C_{y_2}(y_1)$	2 pF
x_1 to x_2	$C_{x_1x_2}$	2 pF
y_1 to y_2	$C_{y_1y_2}$	1.5 pF
Grid No.1 to all other elements	C_{g_1}	5.2 pF
Cathode to all other elements	C_k	5 pF

FOCUSING Electrostatic**DEFLECTION** Double electrostatic

x plates symmetrical

y plates symmetrical

Angle between x and y traces (each gun) 90 ± 1 °Angle between corresponding x traces
at the centre of the screen max. 0.6 °Angle between corresponding y traces
at the centre of the screen max. 1 °

If use is made of the full deflection capabilities of the tube the deflection plates will intercept part of the electron beam; hence a low impedance deflection plate drive is desirable.

LINE WIDTH

Measured with the shrinking-raster method in the centre of the screen.

Final accelerator voltage	$V_{g_8}(\ell)$	4000 V
Astigmatism-control electrode voltage	V_{g_5}	1000 V 2)
First accelerator voltage	V_{g_2}	1000 V
Beam current	$I_{g_8}(\ell)$	10 μ A
Line width	l. w.	0.4 mm

HELIXPost-deflection accelerator helix resistance min. 100 M Ω

2) See page 5

TYPICAL OPERATING CONDITIONS (each gun, if applicable)

Final accelerator voltage	$V_{g8}(\ell)$	4000	V	
Intergun shield voltage	V_{g7}	1000 \pm 100	V	1)
Geometry-control electrode voltage	V_{g6}	1000 \pm 100	V	1)
Astigmatism-control electrode voltage	V_{g5}	1000 \pm 100	V	2)
Focusing electrode voltage	V_{g4}	200 to 320	V	
Deflection-blanking electrode voltage	V_{g3}	1000	V	
Deflection-blanking control voltage for blanking a beam current $I_{g8}(\ell) = 10 \mu\text{A} \Delta V_{g3}$	V_{g3}	max.	40	V
First accelerator voltage	V_{g2}	1000	V	
Control grid voltage for extinction of focused spot	V_{g1}	-25 to -90	V	
Deflection coefficient, horizontal	M_x	14 to 20	V/cm	
vertical	M_y	6.4 to 8.4	V/cm	
Deviation of linearity of deflection		max.	2	% 3)
Geometry distortion			see note 4	
Interaction factor		max.	$2 \cdot 10^{-3}$	mm/ V_{DC} 5)
Tracking error			1.2	mm 6)

LIMITING VALUES (each gun, if applicable) (Absolute max. rating system)

Final accelerator voltage	$V_{g8}(\ell)$	max.	5000	V
		min.	2700	V
Intergun shield voltage	V_{g7}	max.	1200	V
Geometry control electrode voltage	V_{g6}	max.	1200	V
Astigmatism control electrode voltage	V_{g5}	max.	1200	V
		min.	800	V
Focusing electrode voltage	V_{g4}	max.	1200	V
Beam blanking electrode voltage	V_{g3}	max.	1200	V
First accelerator voltage	V_{g2}	max.	1200	V
		min.	200	V
Control grid voltage, negative	$-V_{g1}$	max.	200	V
positive	V_{g1}	max.	0	V
Cathode to heater voltage, cathode positive	V_{kf}	max.	125	V
cathode negative	$-V_{kf}$	max.	125	V
Average cathode current	I_k	max.	300	μA
Screen dissipation	W_ℓ	max.	3	mW/cm ²
Ratio $V_{g8}(\ell)/V_{g5}$	$V_{g8}(\ell)/V_{g5}$	max.	4	

1) 2) 3) 4) 5) 6) See page 5

CIRCUIT DESIGN VALUES (each gun, if applicable)

Focusing voltage	V_{g4}	200 to 320 V	per kV of V_{g2}
Control grid voltage for extinction of focused spot	V_{g1}	-25 to -90 V	per kV of V_{g2}
Deflection coefficient at $V_{g8}(\ell)/V_{g5} = 4$			
horizontal	M_x	14 to 20 V/cm	per kV of V_{g5}
vertical	M_y	6.4 to 8.4 V/cm	per kV of V_{g5}
Focusing electrode current	I_{g4}	-15 to +10 μ A	
Control grid circuit resistance	R_{g1}	max. 1.5 $M\Omega$	

- 1) This tube is designed for optimum performance when operating at the ratio $V_{g8}(\ell)/V_{g5} = 4$. Operation at higher ratio may result in changes in deflection uniformity and geometry distortion. The geometry control electrode voltage and the intergun shield voltage should be adjusted for optimum performance. For any necessary adjustment its potential will be within the stated range.
- 2) The astigmatism control electrode voltage should be adjusted for optimum spot shape. For any necessary adjustment its potential will be within the stated range.
- 3) The sensitivity at a deflection of $\leq 75\%$ of the useful scan will not differ from the sensitivity at a deflection of 25% of the useful scan by more than the indicated value.
- 4) A graticule consisting of concentric rectangles of 60 mm x 60 mm and 57.5 mm x 57.5 mm is aligned with the electrical x axis of the tube. The edges of a raster will fall between these rectangles with optimum potentials applied.
- 5) The deflection of one beam when balanced DC voltages are applied to the deflection plates of the other beam, will not be greater than the indicated value.
- 6) With 50 mm vertical traces superimposed at the tube face centre and deflected horizontally ± 4 cm by voltages proportional to the relative deflection factors, horizontal separation of the corresponding points of the traces will not be greater than the indicated value.

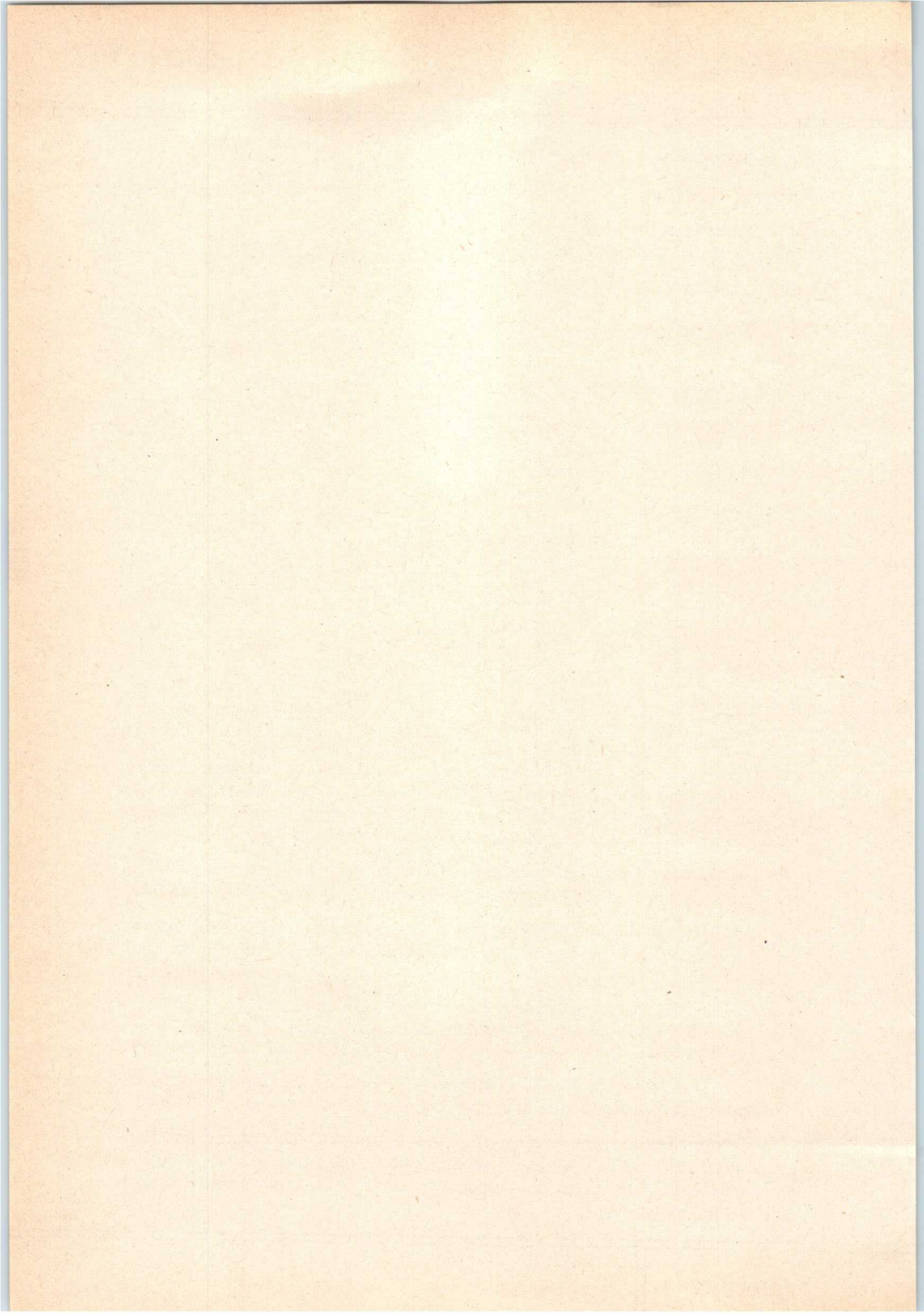

INSTRUMENT CATHODE-RAY TUBE

14 cm diagonal, rectangular flat faced, split-beam oscilloscope tube with mesh and metal-backed screen.

QUICK REFERENCE DATA			
Final accelerator voltage	$V_{g7(\ell)}$	10	kV
Display area		100 x 80	mm^2
Deflection coefficient, horizontal vertical	M_x	13,5	V/cm
	M_y'	9	V/cm
	M_y''	9	V/cm
Overlap of the systems		100	%

SCREEN : Metal-backed phosphor

	Colour	Persistence
E 14- 100GH	green	medium short

Useful screen dimensions	min.	100 x 80	mm^2
Useful scan at $V_{g7(\ell)}/V_{g2}, g4 = 6,7$			
horizontal	min.	100	mm
vertical (each system)	min.	80	mm
overlap		100	%
Spot eccentricity in horizontal direction	max.	7	mm
in vertical direction	max.	10	mm

HEATING : indirect by A. C. or D. C. ; parallel supply

Heater voltage	V_f	6,3	V
Heater current	I_f	300	mA

MECHANICAL DATA

Dimensions in mm

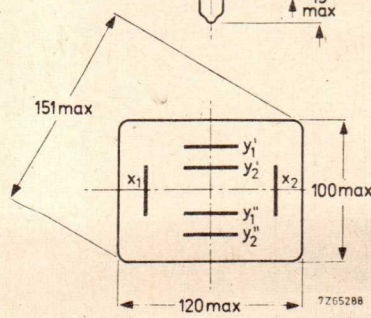
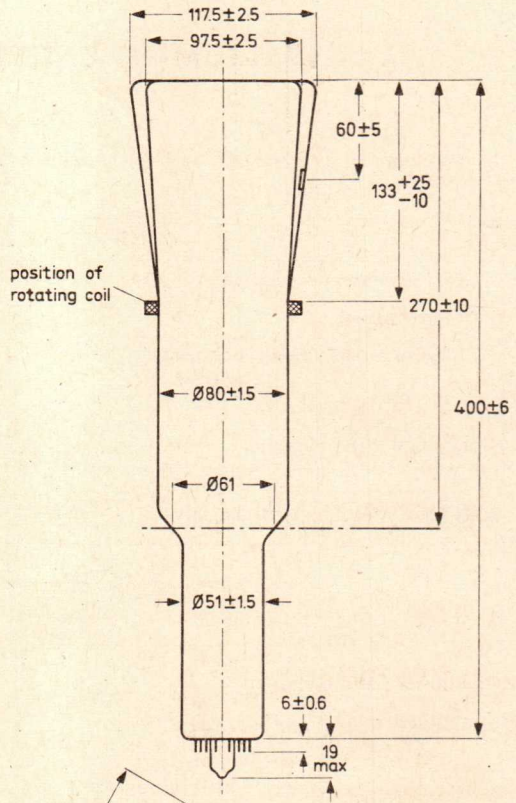
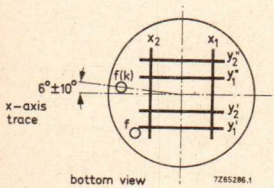
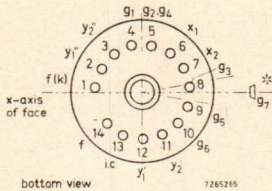
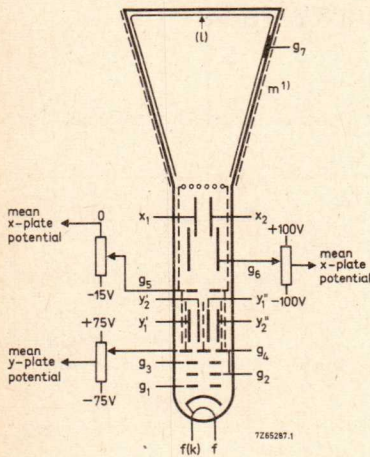

1) The external conductive coating should be earthed

* The centre of the contact is located within a square of 10 mm x 10 mm around the true geometrical position.

Mounting position: any

The tube should not be supported by the base alone and under no circumstances should the socket be allowed to support the tube.

MECHANICAL DATA (continued)Dimensions and connections

See also outline drawing.

Overall length (socket included)	max.	425 mm
Face dimensions	max.	120 x 100 mm ²

<u>Net weight</u>	approx.	900 g
-------------------	---------	-------

<u>Base</u>	14-pin all glass
-------------	------------------

Accessories

Socket (supplied with tube)	type	55566
Final accelerator contact connector	type	55563A

FOCUSING Electrostatic

DEFLECTION Double electrostatic
 x-plates symmetrical
 y-plates symmetrical

If the full deflection capacity of the tube is used, part of the beam is intercepted by the deflection plates; hence a low-impedance deflection plate drive is desirable.

Angle between x and y traces (each beam)		$90 \pm 1^\circ$
Angle between corresponding y traces at screen centre	max.	45'
Angle between x trace and horizontal axis of the face	max.	0°

See page 6

LINE WIDTH

Measured with the shrinking raster method under typical operating conditions, and adjusted for optimum spot size at a beam current of 5 μ A per system.

Line width at screen centre	l.w approx.	0,35 mm
-----------------------------	-------------	---------

CAPACITANCES

x_1 to all other elements except x_2	$C_{x_1(x_2)}$	8 pF
x_2 to all other elements except x_1	$C_{x_2(x_1)}$	8 pF
y_1' to all other elements except y_2'	$C_{y_1'(y_2')}$	4 pF
y_2' to all other elements except y_1'	$C_{y_2'(y_1')}$	5,5 pF
y_1'' to all other elements except y_2''	$C_{y_1''(y_2'')}$	5 pF
y_2'' to all other elements except y_1''	$C_{y_2''(y_1'')}$	4 pF
External conductive coating to all other elements	C_m	800 pF

CAPACITANCES (continued)

x_1 to x_2	$C_{x_1x_2}$	3 pF
y_1' to y_2'	$C_{y_1'y_2'}$	1 pF
y_1'' to y_2''	$C_{y_1''y_2''}$	1 pF
y_1' to y_1''	$C_{y_1'y_1''}$	0,005 pF
y_2' to y_2''	$C_{y_2'y_2''}$	0,005 pF
y_1' to y_2''	$C_{y_1'y_2''}$	0,001 pF
y_2' to y_1''	$C_{y_2'y_1''}$	0,015 pF
Control grid to all other elements	C_{g_1}	6 pF
Cathode and heater to all other elements	$C_{kf/R}$	3 pF

NOTES

- 1) This tube is designed for optimum performance when operating at a ratio $V_{g7(\ell)}/V_{g2, g4} = 6, 7$.
The geometry control voltage V_{g_6} should be adjusted within the indicated range (values with respect to the mean x-plate potential).
- 2) A negative control voltage on g_5 (with respect to the mean x-plate potential) will cause some pincushion distortion and less background light. By varying the two voltages V_{g_5} and V_{g_6} it is possible to find the best compromise between background light and raster distortion.
- 3) The astigmatism control electrode voltage should be adjusted for optimum spot shape. For any necessary adjustment its potential will be within the stated range.
- 4) The sensitivity at a deflection less than 75% of the useful scan will not differ from the sensitivity at a deflection of 25% of the useful scan by more than the indicated value.
- 5) A graticule, consisting of concentric rectangles of 100 mm x 80 mm and 96 mm x 77 mm is aligned with the electrical x-axis of the tube. With optimum correction potentials applied a raster of each system will fall between these rectangles.

TYPICAL OPERATING CONDITIONS

Final accelerator voltage	$V_{g7}(\ell)$	10	kV	
Geometry control electrode voltage	V_{g6}	1500 ± 100	V	1)
Interplate shield voltage	V_{g5}	1500	V	
Background illumination control voltage	ΔV_{g5}	0 to -15	V	2)
Focusing electrode voltage	V_{g3}	350 to 650	V	
First accelerator voltage	$V_{g2}, g4$	1500	V	
Astigmatism control voltage	$\Delta V_{g2}, g4$	± 75	V	3)
Control grid voltage for extinction of focused spot	V_{g1}	-20 to -70	V	
Deflection coefficient, horizontal	M_x	12,5	V/cm	
		< 14	V/cm	
		9	V/cm	
vertical	M_y'	< 10	V/cm	
		9	V/cm	
	M_y''	< 10	V/cm	
Deviation of deflection linearity		< 2	%	4)
Geometry distortion		see note 5)		
Useful scan, horizontal		> 100	mm	
		> 80	mm	
Overlap of the two systems, horizontal		100	%	
		100	%	

LIMITING VALUES (Absolute max. rating system)

Final accelerator voltage	$V_{g7}(\ell)$	max.	13	kV
		min.	9	kV
Geometry control electrode voltage	V_{g6}	max.	2200	V
Interplate shield voltage	V_{g5}	max.	2200	V
Focusing electrode voltage	V_{g3}	max.	2200	V
First accelerator and astigmatism control electrode voltage	$V_{g2}, g4$	max.	2200	V
		min.	1350	V
Control grid voltage	$-V_{g1}$	max.	200	V
		min.	0	V
Voltage between astigmatism control electrode and any deflection plate	V_{g4}/x V_{g4}/y	max.	500	V
		max.	500	V
Grid drive average		max.	30	V
Screen dissipation	W_l	max.	8	mW/cm ²
Ratio $V_{g7}(\ell)/V_{g2}, g4$	$V_{g7}(\ell)/V_{g2}, g4$	max.	6,7	

CORRECTION COILS

General

The E14-100GH is provided with a pair of coils L1 and L2 for image rotation which enable the alignment of the x-trace with the x-lines of the graticule.

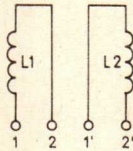

The image rotating coils are wound concentrically around the tube neck. Under typical operating conditions 50A turns are required for the maximum rotation of 5° . Both coils have 850 turns. This means that a current of max. 30 mA per coil is required which can be obtained by using a 24 V supply when the coils are connected in series, or a 12 V supply when they are in parallel.

Connecting the coils

The coi's have been connected to the 4 solderingtags as follows:

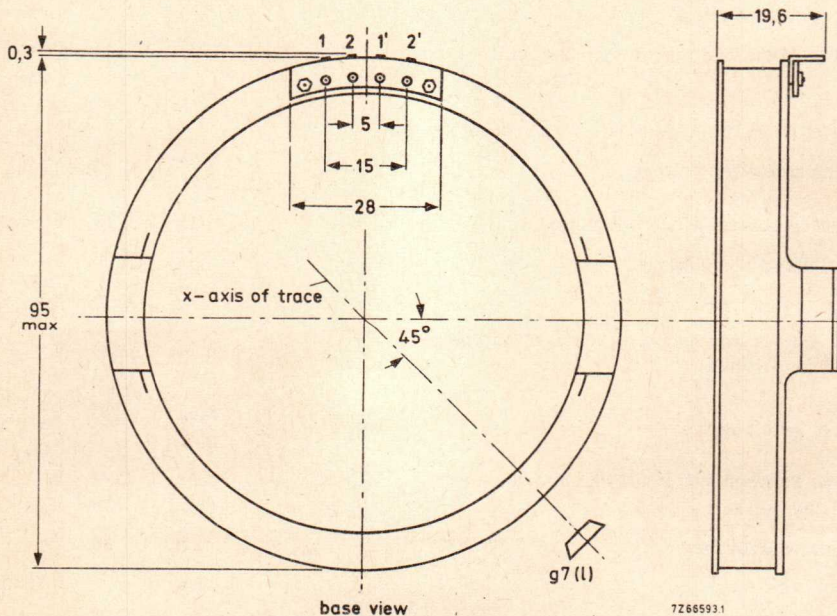

7266593.1

INSTRUMENT CATHODE-RAY TUBE

The E14-101GH is equivalent to the E14-100GH but has no rotating coil.

Devoegen

Correction magnet

bruidelentring.



INSTRUMENT CATHODE-RAY TUBE

14 cm-diagonal rectangular flat-faced direct-view storage tube with variable persistence and internal graticule, intended for oscilloscope applications.

QUICK REFERENCE DATA

Final accelerator voltage	$V_{g10}(\ell)$	8,5	kV
Display area (10 x 8 divisions of 9 mm)		90 x 72	mm ²
Deflection coefficient, horizontal	M_x	9,5	V/div
	vertical	M_y	4,1 V/div
Writing speed		1	cm/ μ s

SCREEN

Metal backed phosphor

	Colour	Persistence (non-store mode)	Persistence (store mode)
L14-110GH/55	green	medium-short	variable

Useful screen dimensions	min.	90 x 72	mm
Useful scan, horizontal	min.	90	mm
	vertical	min.	72 mm
Spot eccentricity in horizontal and vertical directions	max.	6	mm

The scanned raster can be shifted and aligned with the internal graticule by means of correction coils fitted around the tube by the manufacturer.

HEATING

Writing section

Indirect by a.c. or d.c.; parallel supply

Heater voltage	V_f	6,3	V
Heater current	I_f	300	mA

Viewing section

Indirect by d.c.; parallel supply

Heater voltage	$V_{f'}$	6,3	V
Heater current	$I_{f'}$	300	mA
Heater voltage	$V_{f''}$	6,3	V
Heater current	$I_{f''}$	300	mA



MECHANICAL DATA

Dimensions in mm

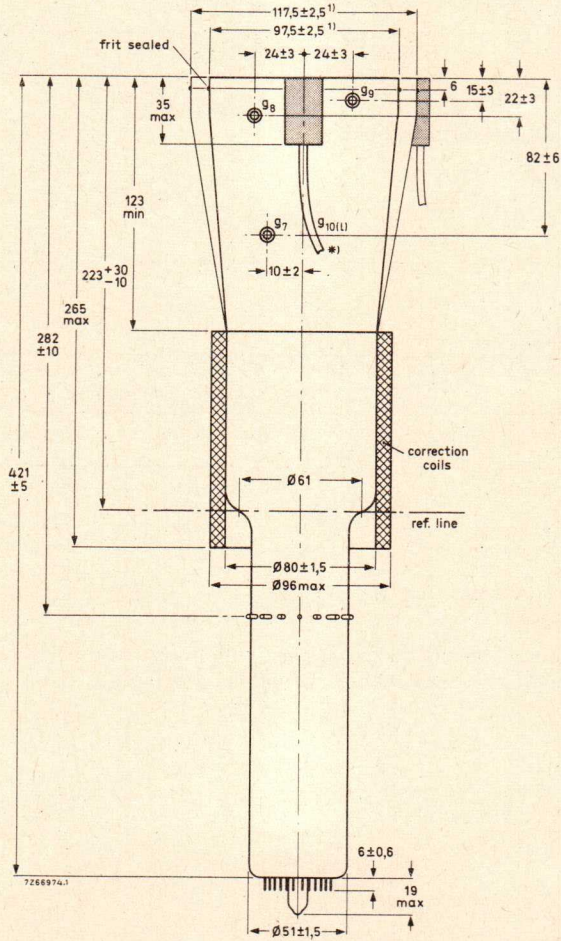

* min. length of cable: 420 mm

¹⁾ The bulge at the frit seal may increase the indicated max. values by not more than 3 mm.

MECHANICAL DATA

Dimensions in mm

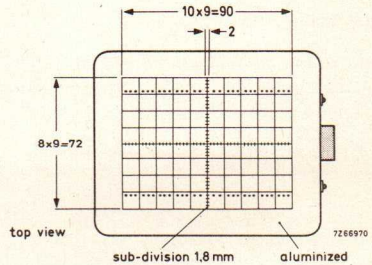
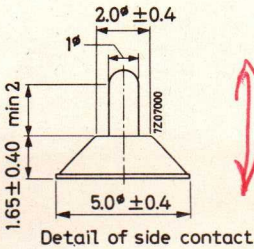
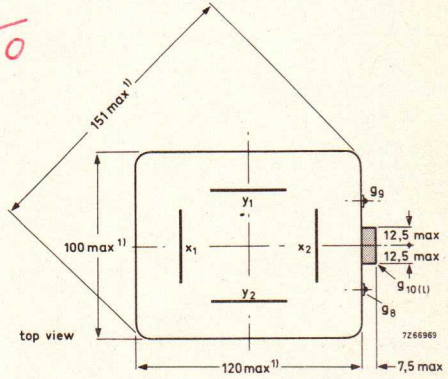
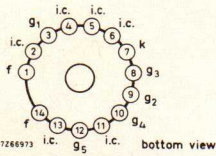
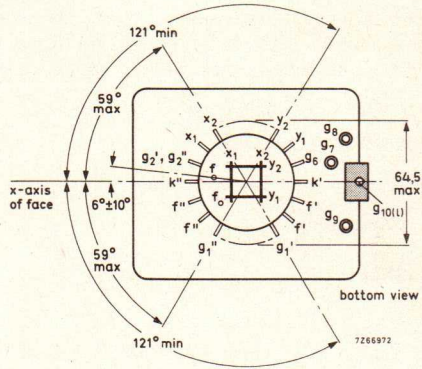
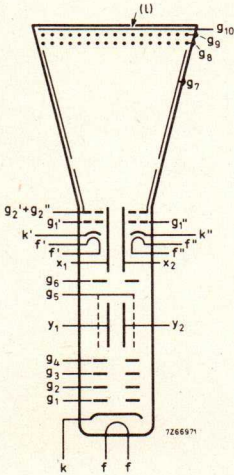

64.5
49.5
15.0
7.5

1.65 - 0.4
2
1.25

Colour of graticule: brown-black
Line width 0,15 mm
Dot diameter 0,3 mm

MECHANICAL DATA (continued)

Mounting position: any

The tube should not be supported by the base alone and under no circumstances should the socket be allowed to support the tube.

The tags near the screen should not be subjected to mechanical stress.

Dimensions and connections

See also outline drawing

Overall length (socket included) max. 445 mm

Face dimensions max. 100 x 120 mm

Net mass approx. 1,1 kg

Base 14 pin, all glass

Accessories

Socket (supplied with tube) type 55566

Side contact connector (14 required) type 55561

FOCUSING electrostatic

DEFLECTION double electrostatic

x-plates symmetrical

y-plates symmetrical

Angle between x and y traces 90 °

Angle between x-trace and x-axis of the internal graticule 0 °

See also "Correction coils"

LINE WIDTH

Measured with the shrinking raster method in the centre of the screen under typical operating conditions, adjusted for optimum spot size at a beam current $I_b = 10 \mu A$ (measured against x-plates)

Line width at the centre of the screen l.w. 0,35 mm

CAPACITANCES

x_1 to all other elements except x_2	$C_{x_1(x_2)}$	6	pF
x_2 to all other elements except x_1	$C_{x_2(x_1)}$	6	pF
y_1 to all other elements except y_2	$C_{y_1(y_2)}$	3	pF
y_2 to all other elements except y_1	$C_{y_2(y_1)}$	3	pF
x_1 to x_2	$C_{x_1x_2}$	2,5	pF
y_1 to y_2	$C_{y_1y_2}$	2	pF
g_1 to all other elements	C_{g_1}	6	pF
g_1' to all other elements	$C_{g_1'}$	5,5	pF
g_1'' to all other elements	$C_{g_1''}$	5,5	pF
k to all other elements	C_k	5	pF
k' to all other elements	$C_{k'}$	5	pF
k'' to all other elements	$C_{k''}$	5	pF
g_7 to all other elements	C_{g_7}	30	pF
g_9 to all other elements	C_{g_9}	<u>25</u>	pF

TYPICAL OPERATION

Conditions

A. Writing section (voltages with respect to writing gun cathode k)

Final accelerator voltage	$V_{g10}(\ell)$	8500	V ¹⁾
Geometry control electrode voltage	V_{g6}	1500 ± 100	V
Deflection plate shield voltage	V_{g5}	1500	V ⁸⁾
Astigmatism control electrode voltage	V_{g4}	1500 ± 50	V
Focusing electrode voltage	V_{g3}	400 to 600	V
First accelerator voltage	V_{g2}	1500	V
Control grid voltage for visual extinction of focused spot	V_{g1}	-40 to -80	V

B. Viewing section (voltages with respect to viewing gun cathodes k' and k'')

Final accelerator voltage	$V_{g10}(\ell)$	7050	V ¹⁾
Backing electrode voltage, storage operation	V_{g9}	0 to 5	V
non-storage operation	V_{g9}	-35	V
Collector voltage	V_{g8}	150	V
Collimator voltage	V_{g7}	30 to 120	V ⁴⁾
First accelerator voltage	$V_{g2'}, g2''$	50	V ⁵⁾
Control grid voltage for cut-off	$V_{g1'}, V_{g1}''$	-30 to -70	V
Cathode current (each viewing gun)	$I_{k'}, I_{k}''$	0,4	mA

Performance

Grid drive for 10 μ A beam current		≈ 25	V
Deflection coefficient, horizontal	M_x		9,5 V/div
		max.	10,5 V/div
vertical	M_y		4,1 V/div
		max.	4,4 V/div
Geometry distortion		see note 2	
Deviation of linearity of deflection		max.	2 % ³⁾
Useful scan, horizontal		min.	90 mm
		vertical	min.
Writing speed in store mode		greater than 100	div/ms ⁶⁾
Storage time		greater than 1,5	min ⁷⁾

NOTES

- 1) These values are valid at cut-off of both flood guns and the writing gun. The H. T. unit must be capable to supply 0,5 mA. To protect the tube against excessive surge current during erasure, an adequately dimensioned RC-network must be connected in series with the screen terminal lead.

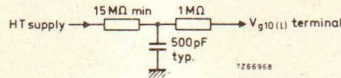

- 2) A graticule consisting of concentric rectangles of 88 mm x 70 mm and 86 mm x 68,5mm is aligned with the electrical x-axis of the tube. With optimum corrections applied, a raster will fall between these rectangles.
- 3) The sensitivity at a deflection less than 75 % of the useful scan will not differ from the sensitivity at a deflection of 25 % of the useful scan by more than the indicated value.
- 4) The collimator electrode voltage should be adjusted for optimum uniformity of background illumination.
- 5) The voltage $V_{g_2', g_2''}$ should be equal to the mean x-plate potential.
- 6) *2-2*
L14-110-
The writing speed is defined as the maximum speed at which a written trace is just visible, starting from a background which is just black. The indicated value is guaranteed for a centred rectangle of 6 (vertical) x 8 (horizontal) divisions, except for the outer corner halves of the four 1 x 1 areas.
The writing speed can be increased to approx. 1 cm/μs if some background is tolerated.
- 7) The storage time is defined as the time required for the brightness of the unwritten background to rise from just zero brightness (viewing-beam cut-off) to 10 % of saturated brightness. At reduced intensity (by pulsing the flood beams) the storage time can be increased.
- 8) This voltage should be equal to the mean y-plate potential.
The mean x and y-plate potentials should be equal for optimum spot quality.

CORRECTION COILS

General

The L14-110GH/55 is provided with a coil unit consisting of: (see Fig. 1)

1. a pair of coils L_3 and L_4 which enable the angle between the x and y traces at the centre of the screen to be made exactly 90° (orthogonality correction).
2. a pair of coils L_1 and L_2 for image rotation which enable the alignment of the x-trace with the x-lines of the graticule.

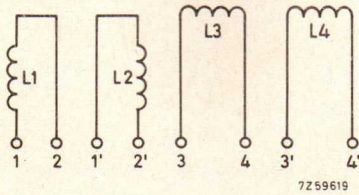

Fig. 1

Orthogonality (coils L3 and L4)

The current required under typical operating conditions without a mu-metal shield being used is max. 20 mA for complete correction of orthogonality. It will be 30% to 50% lower with shield, depending on the shield diameter. The resistance of the coil is approx. 225 Ω .

Image rotation (coils L1 and L2)

The image rotation coils are wound concentrically around the tube neck. Under typical operating conditions 22 A-turns are required for maximum rotation of 5°. Both coils have 850 turns. This means that a current of max. 12,5 mA per coil is required which can be obtained by using a 12 V supply when the coils are connected in series or a 6 V supply when they are in parallel.

Connecting the coils

The coils have been connected to 8 soldering tags according to Fig. 2.

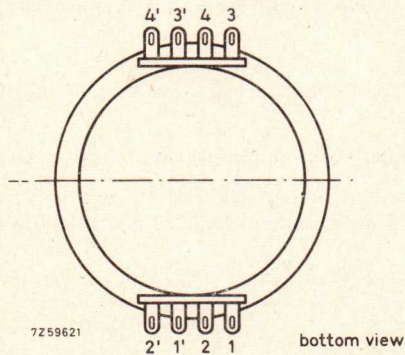

Fig. 2

With L3 and L4 connected in series according to Fig. 3 a current in the direction indicated will produce a clockwise rotation of the vertical trace and an anti-clockwise rotation of the horizontal trace.

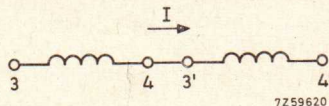

Fig. 3

OPERATING NOTES**Modes of operation**1 Store mode

a. Dynamic erasure (variable persistence)

Dynamic erasure can be achieved by applying erasing pulses of positive polarity to the backing electrode.

The pulse amplitude required is approximately 9 V (< 15 V) and the persistence of a stored display can be controlled by varying the duty factor of these pulses.

b. Static erasure

If no dynamic erasing pulses are applied, the storage time is limited by the potential shift of the storage layer due to landing of positive ions.

In order to erase a stored display, the backing electrode should first be connected to the collector electrode voltage and then returned to its original potential for about 100 ms; after that, an erasing pulse of positive polarity and a duration of not less than 300 ms should be applied. For the adjustment of the amplitude of this pulse see "Procedure of adjustment".

2 Non-store mode

For non-store operation, it is sufficient to make the backing electrode about 35 V negative with respect to the viewing gun cathodes. The viewing guns should not be switched off in this mode of operation since slight variations in raster geometry and deflection sensitivity might otherwise be caused. Care should be taken, especially when switching from store mode to non-store mode, that excessive writing beam current is avoided, as otherwise the storage layer may be damaged.

Procedure of adjustment

a. Adjust the cathode current of each viewing gun to 0,4 mA by means of its control grid voltage.

b. Adjustment of the erasing pulse amplitude (static erasure)

The pulse amplitude should be just sufficient to suppress any background illumination at the centre of the display area (this adjustment should be done under low ambient light conditions).

Data on storage time and maximum writing speed are based on erasure to "just black". A larger pulse amplitude (erasure to "blacker than black") yields a longer storage time at the expense of maximum writing speed. On the other hand, writing speed can be increased if some background illumination is tolerated.

To erase to "just black" the amplitude of this pulse is approximately 9 V.

c. Adjustment of the collimator voltage

With dynamic erasing pulses applied and a persistence control setting that yields a convenient background illumination intensity, the collimator voltage is adjusted for optimum background uniformity. This voltage will be approximately 80 V with respect to the viewing gun cathode potential. If this voltage is too high or too low, there is a decrease of intensity at the four corners or at the centres of the vertical edges of the display area respectively.

For a good erasure of the display, the collimator voltage should be as low as possible.

INSTRUMENT CATHODE-RAY TUBE

14 cm-diagonal rectangular flat-faced direct-view storage tube with split-beam writing gun, variable persistence and internal graticule, intended for oscilloscope applications.

QUICK REFERENCE DATA

Final accelerator voltage	$V_{g10} (\ell)$	8,5	kV
Useful scan (10 x 8 divisions of 9 mm)		90 x 72	mm
Deflection coefficient, horizontal	M_x	9,5	V/div
vertical, system 1	$M_{y'}$	8,5	V/div
vertical, system 2	$M_{y''}$	8,5	V/div
Overlap of the systems		100	%
Writing speed		1	cm/ μ s

SCREEN

Metal-backed phosphor

	Colour	Persistence (non-store mode)	Persistence (store mode)
L14-130GH/55	green	medium short	variable

Useful screen dimensions	min.	90 x 72	mm
Useful scan, horizontal	min.	90	mm
vertical (each system)	min.	72	mm
overlap		100	%
Spot eccentricity in horizontal direction	max.	6	mm
in vertical direction	max.	9	mm

The scanned raster can be aligned with the internal graticule by means of correction coils fitted around the tube by the manufacturer.

HEATING

Writing section

Indirect by a. c. or d. c. ; parallel supply

Heater voltage	V_f	6,3	V
Heater current	I_f	300	mA

Viewing section

Indirect by d. c. ; parallel supply

Heater voltage	$V_{f'}$	6,3	V
Heater current	$I_{f'}$	300	mA
Heater voltage	$V_{f''}$	6,3	V
Heater current	$I_{f''}$	300	mA

MECHANICAL DATA

Dimensions in mm

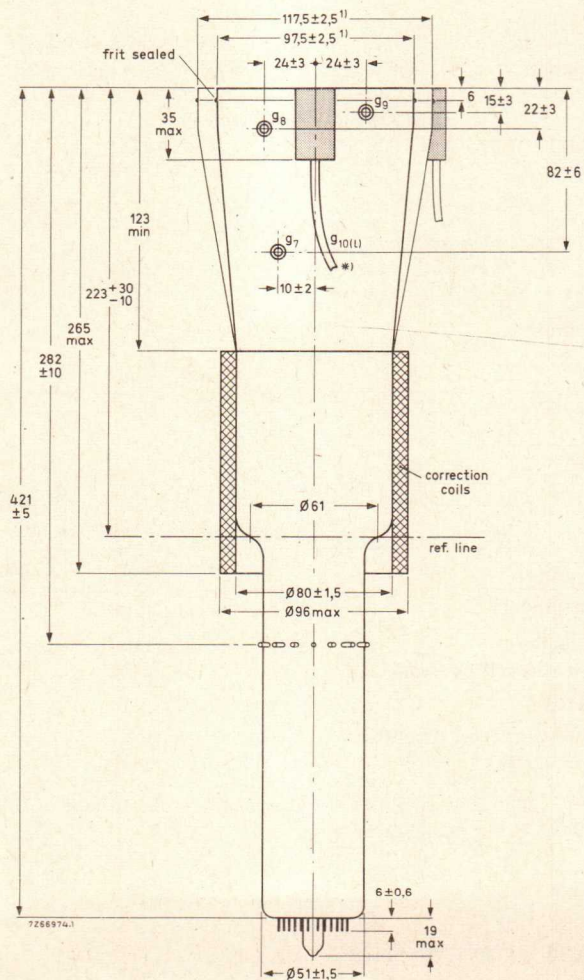

* min. length of cable: 420 mm

¹⁾ The bulge at the frit seal may increase the indicated max. values by not more than 3 mm.

Dimensions in mm

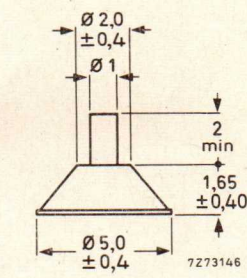
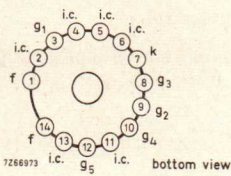
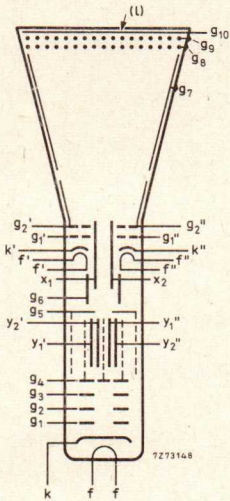

detail of side contact

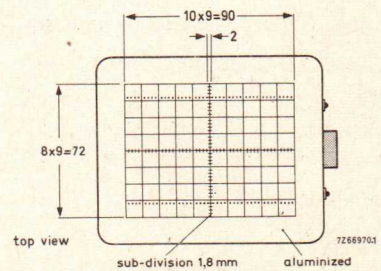
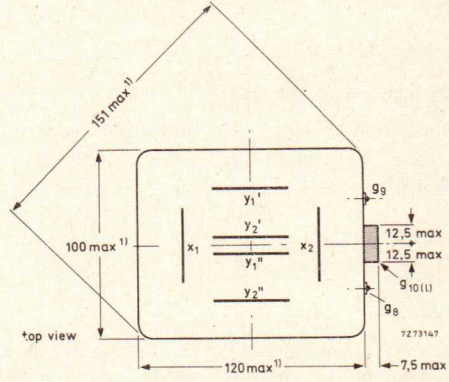
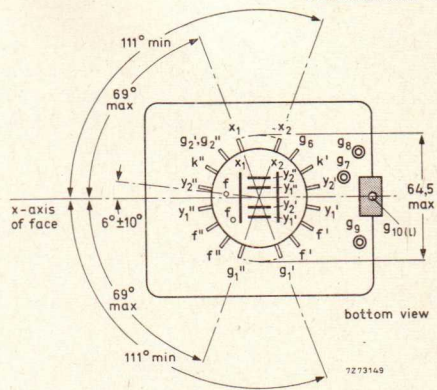

Colour of graticule	brown-black
Line width	0,15
Dot diameter	0,3 mm

Mounting position: any

The tube should not be supported by the base alone and under no circumstances should the socket be allowed to support the tube.

The tags near the screen should not be subjected to mechanical stress.

Dimensions and connections

See also outline drawing

Overall length (socket included)	max.	445	mm
Face dimensions	max.	100 x 120	mm
<u>Net mass</u>	approx.	1, 1	kg
<u>Base</u>		14 pin, all glass	

Accessories

Socket (supplied with tube)	type	55566
Side contact connector (16 required)	type	55561

FOCUSING

electrostatic

DEFLECTION

double electrostatic

x-plates

symmetrical

y-plates

symmetrical

If use is made of the full deflection capabilities of the tube the deflection plates will block part of the electron beams; hence a low impedance deflection plate drive is desirable.

Angle between x and y traces, each beam 90°

Angle between x-trace and x-axis of the internal graticule 0°

Angle between corresponding y-traces at the centre of the screen < 45'

See also "Correction coils"

LINE WIDTH

Measured in the centre of the screen with the shrinking raster method, under typical operating conditions, adjusted for optimum spot size at a beam current $I_B = 5 \mu A$ per system (measured against x-plates)

Line width at the centre of the screen l. w. 0, 40 mm

CAPACITANCES

Writing section

x_1 to all other elements except x_2	$C_{x_1(x_2)}$	9 pF
x_2 to all other elements except x_1	$C_{x_2(x_1)}$	9 pF
y_1' to all other elements except y_2'	$C_{y_1'(y_2')}$	5 pF
y_2' to all other elements except y_1'	$C_{y_2'(y_1')}$	6 pF
y_1'' to all other elements except y_2''	$C_{y_1''(y_2'')}$	6 pF
y_2'' to all other elements except y_1''	$C_{y_2''(y_1'')}$	5 pF
x_1 to x_2	$C_{x_1 x_2}$	2, 5 pF
y_1' to y_2'	$C_{y_1' y_2'}$	0, 6 pF
y_1'' to y_2''	$C_{y_1'' y_2''}$	0, 6 pF
y_1' to y_1''	$C_{y_1' y_1''}$	4 fF
y_2' to y_2''	$C_{y_2' y_2''}$	7 fF
y_1' to y_2''	$C_{y_1' y_2''}$	0, 1 fF
y_2' to y_1''	$C_{y_2' y_1''}$	5 fF
g_1 to all other elements	C_{g_1}	5 pF
k to all other elements	C_k	5 pF

Viewing section

g_1' to all other elements	$C_{g_1'}$	5 pF
g_1'' to all other elements	$C_{g_1''}$	5 pF
k' to all other elements	$C_{k'}$	5 pF
k'' to all other elements	$C_{k''}$	5 pF
g_7 to all other elements	C_{g_7}	35 pF
g_9 to all other elements	C_{g_9}	20 pF

1 fF = 1 femto farad = 10^{-15} farad

TYPICAL OPERATION

Conditions

A. Writing section (voltages with respect to writing gun cathode k)

Final accelerator voltage	$V_{g10(\ell)}$	8500 V ¹⁾
Geometry control electrode voltage	V_{g6}	1500 ± 100 V
Deflection plate shield voltage	V_{g5}	1500 V ⁸⁾
Astigmatism control electrode voltage	V_{g4}	1500 ± 75 V
Focusing electrode voltage	V_{g3}	350 to 650 V
First accelerator voltage	V_{g2}	1500 V
Control grid voltage for visual extinction of focused spot	V_{g1}	-40 to -80 V

B. Viewing section (voltages with respect to viewing gun cathodes k' and k'')

Final accelerator voltage	$V_{g10(\ell)}$	7050 V ¹⁾
Backing electrode voltage, store mode	V_{g9}	1 V
non-store mode	V_{g9}	-35 V
Collector voltage	V_{g8}	150 V
Collimator voltage	V_{g7}	30 to 120 V ⁴⁾
First accelerator voltage	$V_{g2'}, V_{g2''}$	50 V ⁵⁾
Control grid voltage for cut-off	$V_{g1'}, V_{g1''}$	-30 to -70 V
Cathode current (each viewing gun)	$I_{k'}, I_{k''}$	0,4 mA

Performance

Grid drive for 5 µA beam current, per system		≈ 30 V
Deflection coefficient, horizontal	M_x	< 9,5 V/div
		< 10,5 V/div
	vertical, system 1	$M_{y'}$ < 8,5 V/div
	vertical, system 2	$M_{y''}$ < 9,5 V/div
Geometry distortion		see note 2
Deviation of linearity of deflection		max. 2 % ³⁾
Useful scan, horizontal		min. 90 mm
	vertical	min. 72 mm
Writing speed in store mode		greater than 100 div/ms ⁶⁾
Storage time		greater than 1,5 min ⁷⁾

Notes see page 8

NOTES

- 1) These values are valid at cut-off of both viewing (flood) guns and the writing gun. The H. T. unit must be capable of supplying 0,5 mA. To protect the tube against excessive surge current during erasure, an adequately dimensioned RC-network must be connected in series with the screen terminal lead.

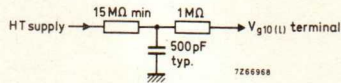

- 2) A graticule consisting of concentric rectangles of 88 mm x 70 mm and 84,8 mm x 67,6 mm is aligned with the electrical x-axis of the tube. With optimum corrections applied, a raster will fall between these rectangles.
- 3) The sensitivity at a deflection less than 75% of the useful scan will not differ by more than the indicated value from the sensitivity at the deflection of 25% of the useful scan.
- 4) The collimator electrode voltage should be adjusted for optimum uniformity of background illumination.
- 5) The voltage V_{g2}' , V_{g2}'' should be equal to the mean x-plate potential.
- 6) *ok* The writing speed is defined as the maximum speed at which a written trace is just visible, starting from a background which is just black. The indicated value is guaranteed for the central 80% of the minimum screen area. In addition, in any corner not more than 4 square divisions fall outside the guaranteed area.
The writing speed etc. see h14-110
- 7) The storage time is defined as the time required for the brightness of the unwritten background to rise from just zero brightness (viewing-beam cut-off) to 10% of saturated brightness. At reduced intensity (by pulsing the flood beams) the storage time can be increased.
- 8) This voltage should be equal to the mean y-plate potential.
The mean x and y-plate potentials should be equal for optimum spot quality.

CORRECTION COILS

General

The L14-130GH/55 is provided with a coil unit consisting of (see Fig. 1):

1. A pair of coils L_3 and L_4 which enable the angle between the x and y traces at the centre of the screen to be made exactly 90° (orthogonality correction).
2. A pair of coils L_1 and L_2 for image rotation which enable the alignment of the x-trace with the x-lines of the graticule.

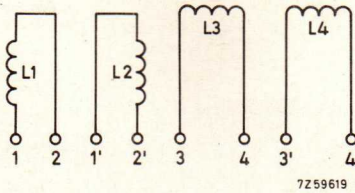

Fig. 1

Orthogonality (coils L₃ and L₄)

The current required under typical operating conditions without a mu-metal shield being used is max. 20 mA for complete correction of orthogonality.

With a shield it will be 30% to 50% lower, depending on the shield diameter.
The resistance of the coil is approx. 225 Ω .

Image rotation (coils L₁ and L₂)

The image rotation coils are wound concentrically around the tube neck.

Under typical operating conditions 22 ampere-turns are required for maximum rotation of 5°. Both coils have 850 turns. This means that a current of max. 12,5 mA per coil is required which can be obtained by using a 12 V supply when the coils are connected in series or a 6 V supply when they are in parallel.

Connecting the coils

The coils have been connected to 8 soldering tags as shown in Fig. 2.

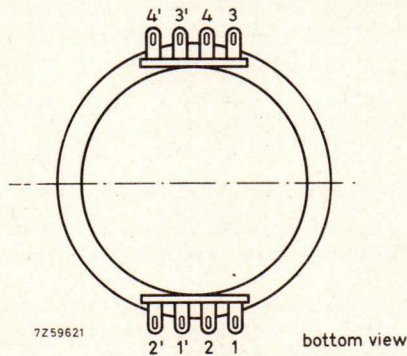

Fig. 2

With L₃ and L₄ connected in series as in Fig. 3 a current in the direction indicated will produce a clockwise rotation of the vertical trace and an anti-clockwise rotation of the horizontal trace.

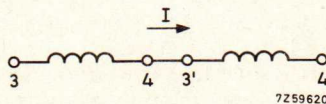

Fig. 3

OPERATING NOTES**Modes of operation**1 Store mode

a. Dynamic erasure (variable persistence)

Dynamic erasure can be achieved by applying erasing pulses of positive polarity to the backing electrode.

The pulse amplitude required is approximately 9 V (< 15 V) and the persistence of a stored display can be controlled by varying the duty factor of these pulses.

b. Static erasure

If no dynamic erasing pulses are applied, the storage time is limited by the potential shift of the storage layer due to landing of positive ions.

In order to erase a stored display, the backing electrode should first be connected to the collector electrode voltage and then returned to its original potential for about 100 ms; after that, an erasing pulse of positive polarity and a duration of not less than 300 ms should be applied. For the adjustment of the amplitude of this pulse see "Procedure of adjustment".

2 Non-store mode

For non-store operation, it is sufficient to make the backing electrode about 35 V negative with respect to the viewing gun cathodes. The viewing guns should not be switched off in this mode of operation since slight variations in raster geometry and deflection sensitivity might otherwise be caused. Care should be taken, especially when switching from store mode to non-store mode, that excessive writing beam current is avoided, otherwise the storage layer may be damaged.

Procedure of adjustment

a. Adjust the cathode current of each viewing gun to 0,4 mA by means of its control grid voltage.

b. Adjustment of the erasing pulse amplitude (static erasure)

The pulse amplitude should be just sufficient to suppress any background illumination at the centre of the display area (this adjustment should be done under low ambient light conditions).

Data on storage time and maximum writing speed are based on erasure to "just black". A larger pulse amplitude (erasure to "blacker than black") yields a longer storage time at the expense of maximum writing speed. On the other hand, writing speed can be increased if some background illumination is tolerable.

To erase to "just black" the amplitude of this pulse is approximately 9 V.

c. Adjustment of the collimator voltage

With dynamic erasing pulses applied and a persistence control setting that yields a convenient background illumination intensity, the collimator voltage is adjusted for optimum background uniformity. This voltage will be approximately 80 V with respect to the viewing gun cathode potential. If this voltage is too high or too low, there is a decrease in intensity at the four corners or at the centres of the vertical edges of the display area respectively.

Monitor and display tubes



MONITOR AND DISPLAY TUBES

PREFERRED TYPES

(Recommended types for new designs)

M17-140W

M17-141W

M24-100W

M24-101W

M31-130W

M31-131W

SCREENS

Although W is the standard screen, certain applications require screens of a different persistence and/or colour (e.g. GH, GR, GM).

Tubes with such screens are supplied to special order.

MONITOR TUBE

17 cm flat-faced rectangular picture tube primarily intended for use as a viewfinder in television cameras.

QUICK REFERENCE DATA

Deflection angle, diagonal	70 °
Focusing	electrostatic
Resolution	min. 650 lines
Overall length	max. 234 mm

SCREEN

Metal-backed phosphor

Luminescence white

Useful rectangle min. 124 x 93 mm²

HEATING

Indirect by A. C. or D. C.; parallel supply

Heater voltage	V_f 6.3 V
Heater current	I_f 300 mA

MECHANICAL DATA

Mounting position: any

Base: Neo Eightar (B8H)

Cavity contact CT8

Accessories

Final accelerator contact
connector 55563A

MECHANICAL DATA

Dimensions in mm

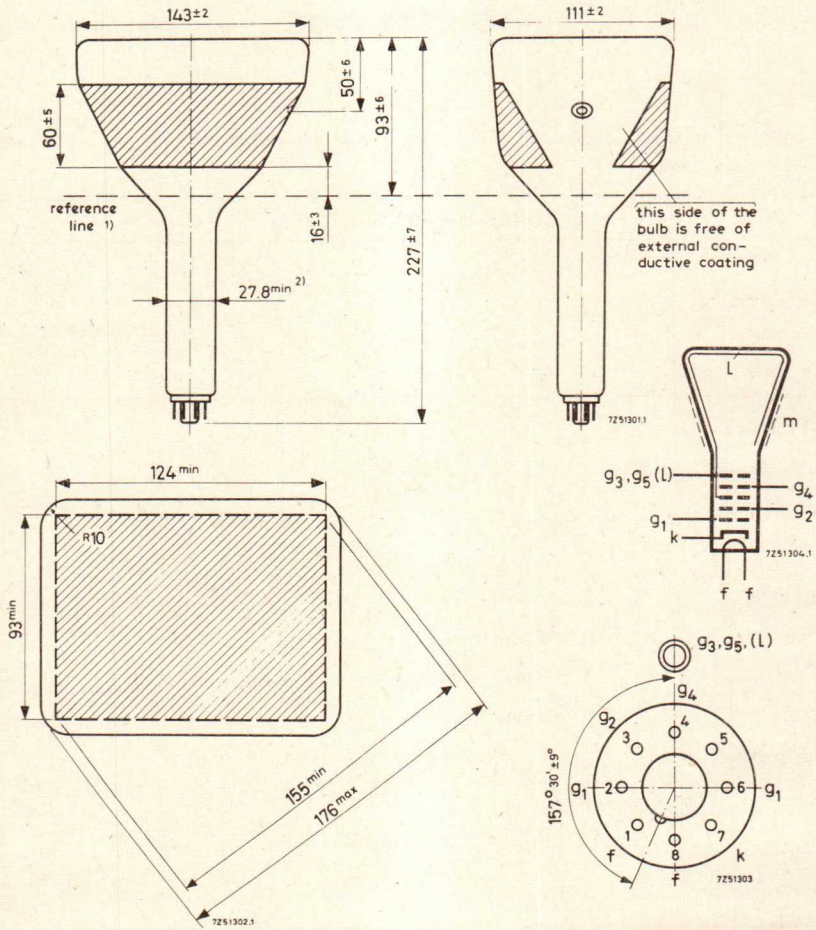

1) Reference line, determined by the plane of the upper edge of the flange of the reference line gauge when the gauge is resting on the cone.

2) The maximum dimension is determined by the reference line gauge.

FOCUSING Electrostatic

The range of focus voltage shown under "Typical operating conditions" results in optimum focus at a beam current of 50 μ A.

DEFLECTION Magnetic ¹⁾

Diagonal deflection angle 70°

REFERENCE LINE GAUGE

Dimensions in mm

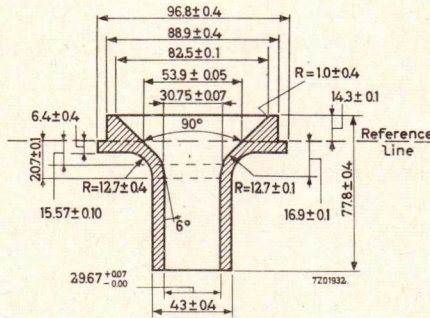

REMARK

With the high voltage used with this tube internal flash-overs may occur, which may destroy the cathode. Therefore it is necessary to provide protective circuits using sparkgaps. The sparkgaps must be connected as follows:

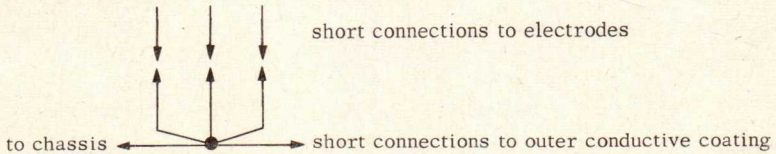

No other connections between outer conductive coating and chassis are permissible.

CAPACITANCES

Final accelerator to external conductive coating	$C_{g3}, g_5(\ell)/m$	300 pF
Cathode to all other elements	C_k	5 pF
Grid No. 1 to all other elements	C_{g1}	7 pF

¹⁾ Recommended deflection coil AT 1071/01

TYPICAL OPERATING CONDITIONS

Final accelerator voltage	$V_{g_3, g_5(\ell)}$	14	kV
Focusing electrode voltage	V_{g_4}	0 to 400	V
First accelerator voltage	V_{g_2}	400	V
Grid no.1 voltage for extinction of focused raster	V_{g_1}	-30 to -62	V

RESOLUTION

Resolution at screen centre measured with shrinking raster method (non-interlaced raster)

at $V_{g_3, g_5(\ell)} = 14$ kV, $V_{g_2} = 400$ V,

$I_f = 50 \mu\text{A}$, $B = 500$ cd/m² (500 nit) min. 650 lines ¹⁾

LIMITING VALUES (Absolute max. rating system)

Final accelerator voltage	$V_{g_3, g_5(\ell)}$	max.	16	kV
		min.	12	kV
Focusing electrode voltage	V_{g_4} $-V_{g_4}$	max.	1	kV
		max.	0.5	kV
		max.	800	V
First accelerator voltage	V_{g_2}	min.	300	V
Grid no.1 voltage, negative	$-V_{g_1}$	max.	150	V
positive	V_{g_1}	max.	0	V
positive peak	V_{g1p}	max.	2	V
Cathode to heater voltage, positive	V_{kf}	max.	250	V
positive peak	V_{kf_p}	max.	300	V ²⁾
negative	$-V_{kf}$	max.	135	V
negative peak	$-V_{kf_p}$	max.	180	V

WARNING

X-ray shielding of the cone is advisable to give protection against possible danger of personal injury arising from prolonged exposure at close range to this tube when operated above 14 kV.

¹⁾ If necessary the resolution can be improved by the use of a beam centring magnet. This magnet, type number 3322 142 11401, is supplied with each tube.

²⁾ During a warm-up period not exceeding 15 s the heater may be 410 V negative with respect to the cathode.

MONITOR TUBE

17 cm flat-faced rectangular picture tube primarily intended for use as a viewfinder in television cameras. The tube is provided with a bonded face plate and a metal mounting band.

QUICK REFERENCE DATA

Deflection angle, diagonal	70 °
Focusing	electrostatic
Resolution	min. 700 lines
Overall length	max. 240 mm

SCREEN

Metal-backed phosphor

Luminescence white

Useful rectangle min. 124 x 93 mm²

HEATING

Indirect by A.C. or D.C.; parallel supply

Heater voltage V_f 6.3 V

Heater current I_f 300 mA

MECHANICAL DATA

Mounting position: any

Base: Neo Eightar (B8H)

Cavity contact CT8

Accessories

Final-accelerator contact connector 55563A

MECHANICAL DATA

Dimensions in mm

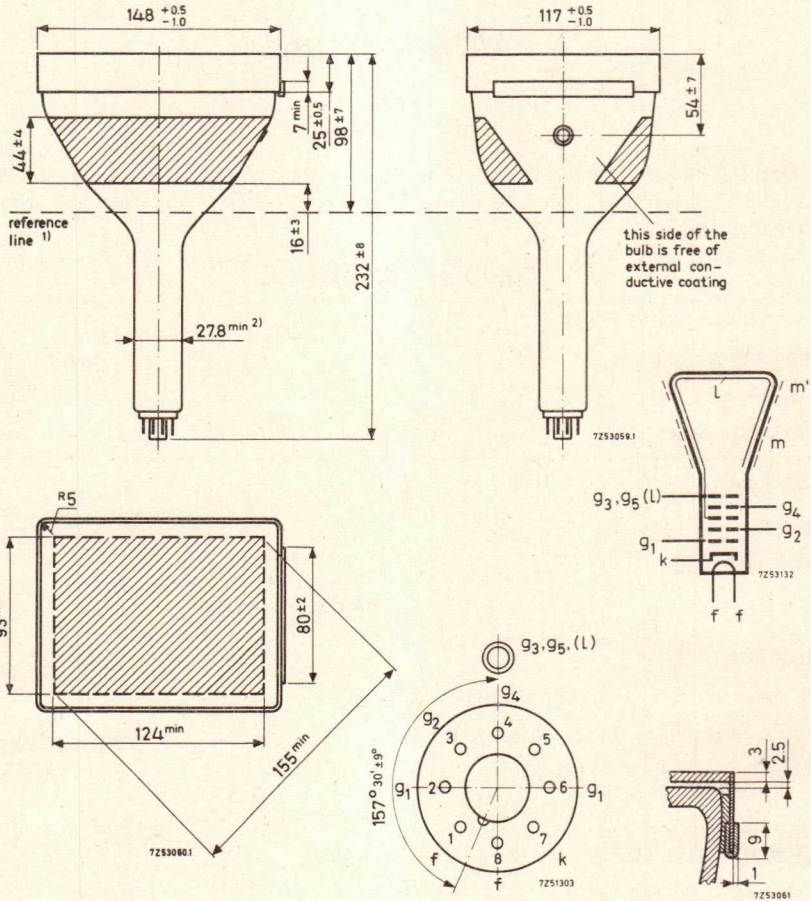

1) Reference line, determined by the plane of the upper edge of the flange of the reference line gauge when the gauge is resting on the cone.

2) The maximum dimension is determined by the reference line gauge.

FOCUSING Electrostatic

The range of focus voltage shown under "Typical operating conditions" results in optimum focus at a beam current of 50 μ A.

DEFLECTION Magnetic 1)

Diagonal deflection angle 70°

REFERENCE LINE GAUGE

Dimensions in mm

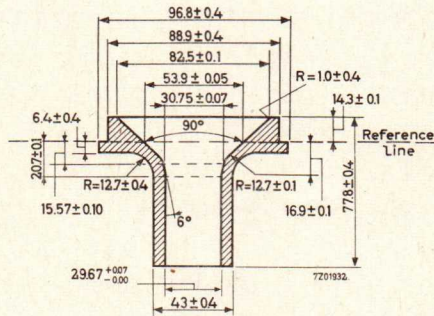

REMARK

With the high voltage used with this tube internal flash-overs may occur, which may destroy the cathode. Therefore it is necessary to provide protective circuits using sparkgaps. The sparkgaps must be connected as follows:

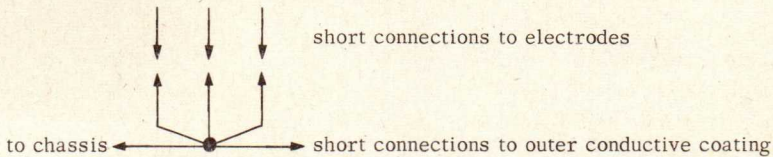

No other connections between outer conductive coating and chassis are permissible.

CAPACITANCES

Final accelerator to metal band	$C_{g_3, g_5}(\ell)/m'$	135 pF
Final accelerator to external conductive coating	$C_{g_3, g_5}(\ell)/m$	240 pF
Cathode to all other elements	C_k	5 pF
Grid No. 1 to all other elements	C_{g_1}	7 pF

1) Recommended deflection coil AT1071/01

TYPICAL OPERATING CONDITIONS

Final accelerator voltage	$V_{g_3, g_5(\ell)}$	14	16	kV
Focusing electrode voltage	V_{g_4}	0 to 400	0 to 400	V
First accelerator voltage	V_{g_2}	400	600	V
Grid no.1 voltage for extinction of focused raster	V_{g_1}	-30 to -62	-40 to -90	V

RESOLUTION

Resolution at screen centre measured with shrinking raster method (non-interlaced raster)

at $V_{g_3, g_5(\ell)} = 14$ kV, $V_{g_2} = 400$ V,

$I_\ell = 50 \mu\text{A}$, $B = 500 \text{ cd/m}^2$ (500 nit) min. 650 lines ¹⁾

at $V_{g_3, g_5(\ell)} = 16$ kV, $V_{g_2} = 600$ V,

$I_\ell = 50 \mu\text{A}$, $B = 600 \text{ cd/m}^2$ (600 nit) min. 700 lines ¹⁾

LIMITING VALUES (Absolute max. rating system)

Final accelerator voltage	$V_{g_3 g_5(\ell)}$	max.	18	kV	
		min.	12	kV	
Focusing electrode voltage	V_{g_4}	max.	1	kV	
		$-V_{g_4}$	max.	0.5 kV	
First accelerator voltage	V_{g_2}	max.	800	V	
		min.	300	V	
Grid no.1 voltage, negative	$-V_{g_1}$	max.	150	V	
		positive	V_{g_1}	max.	0 V
		positive peak	$V_{g_1 p}$	max.	2 V
Cathode to heater voltage, positive	V_{kf}	max.	250	V	
		positive peak	V_{kf}^p	max.	300 V ²⁾
		negative	$-V_{kf}^p$	max.	135 V
		negative peak	$-V_{kf p}$	max.	180 V

WARNING

X-ray shielding of the cone is advisable to give protection against possible danger of personal injury arising from prolonged exposure at close range to this tube when operated above 14 kV.

¹⁾ If necessary the resolution can be improved by the use of a beam centring magnet. This magnet, type number 3322 142 11401, is supplied with each tube.

²⁾ During a warm-up period not exceeding 15 s the heater may be 410 V negative with respect to cathode.

MONITOR TUBE

21 cm rectangular television tube with metal-backed screen primarily intended for use as a precision monitor.

SCREEN

Metal-backed phosphor

Luminescence white

HEATING

Indirect by a. c. or d. c. ; parallel supply

Heater voltage

V_f 11 $V \pm 10\%$

Heater current

I_f 70 mA

FOCUSING

electrostatic

DEFLECTION

magnetic

Diagonal deflection angle

90°

REFERENCE LINE GAUGE

Dimensions in mm

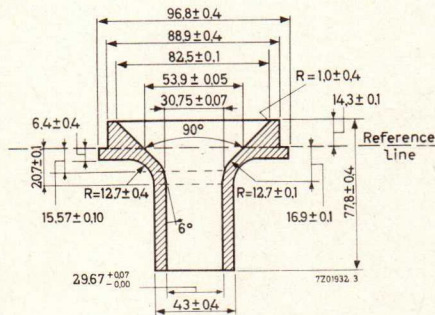

TYPICAL OPERATING CONDITIONS

Final accelerator voltage	$V_{g3, g5(l)}$	12	kV
Focusing electrode voltage	V_{g4}	0 to 400	V
First accelerator voltage	V_{g2}	400	V
Grid no. 1 voltage for visual extinction of focused raster (grid drive service)	V_{g1}	-32 to -69	V
Cathode voltage for visual extinction of focused raster (cathode drive service)	V_k	29 to 62	V

MECHANICAL DATA

Base; Neo eightar (B8H)

Final accelerator connector type 55563A

MECHANICAL DATA (continued)

Dimensions in mm

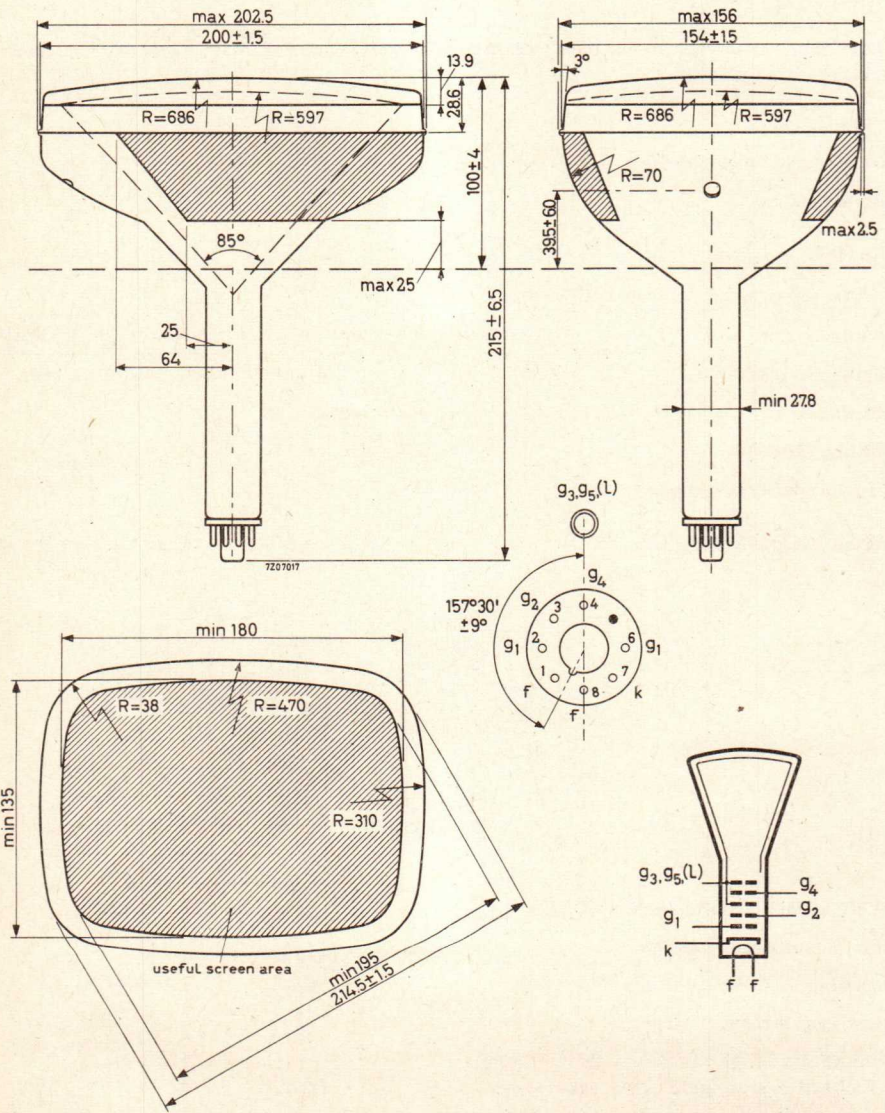

Mounting position: any

Except vertical with the screen downward and the axis of the tube making an angle of less than 20° with the vertical.

MONITOR TUBE

21 cm rectangular television tube with metal backed screen primarily intended for use as a picture monitor tube.

SCREEN

Metal backed phosphor

Luminescence white

Light transmission of face glass 80 %

HEATING

Indirect by A.C. or D.C.; parallel supply

Heater voltage $V_f = 6.3 \text{ V}$

Heater current $I_f = 300 \text{ mA}$

FOCUSING electrostatic

The range of focus voltage shown under "Typical operating conditions" results in optimum focus at a beam current of $100 \mu\text{A}$.

DEFLECTION magnetic

Diagonal deflection angle 110°

TYPICAL OPERATION

Final accelerator voltage $V_{g_3, g_5(\ell)} = 16 \text{ kV}$

Focusing electrode voltage $V_{g_4} = 0 \text{ to } 400 \text{ V}$

First accelerator voltage $V_{g_2} = 300 \text{ V}$

Grid No.1 voltage for extinction of
focused raster $V_{g_1} = -35 \text{ to } -72 \text{ V}$

MECHANICAL DATA

Dimensions in mm

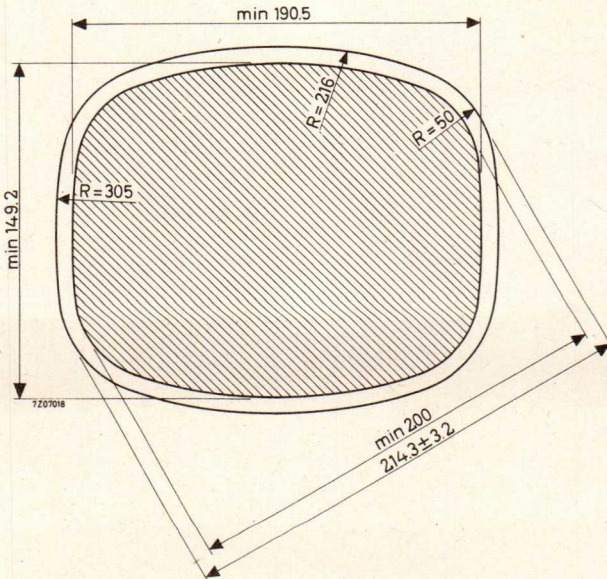
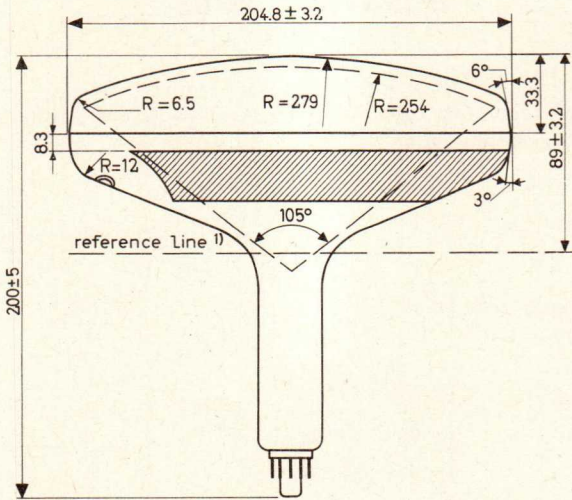

MECHANICAL DATA (continued)

Dimensions in mm

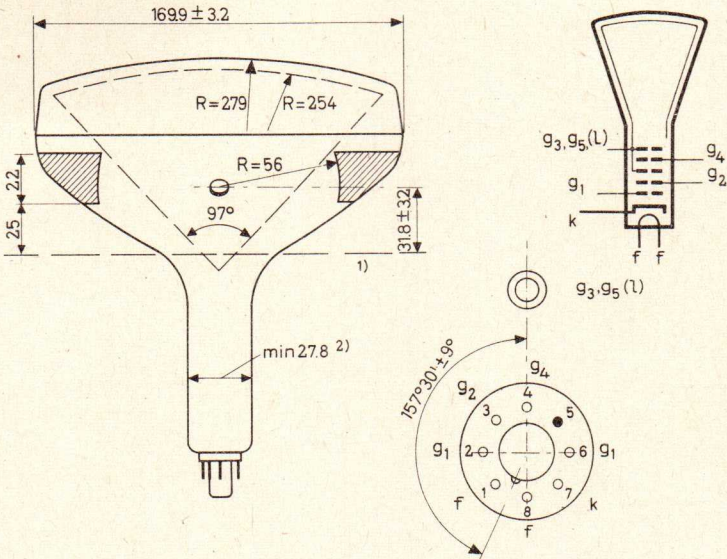

Mounting position: any

Except vertical with the screen downward and the axis of the tube making an angle of less than 20° with the vertical.

Base:

Neo Eightar (B8H)

Cavity contact

CT8

Accessories

Final accelerator connector

type 55563A

1) Reference line, determined by the plane of the upper edge of the flange of the reference line gauge JEDEC 126 when the gauge is resting on the cone.

2) The maximum dimension is determined by the reference line gauge.

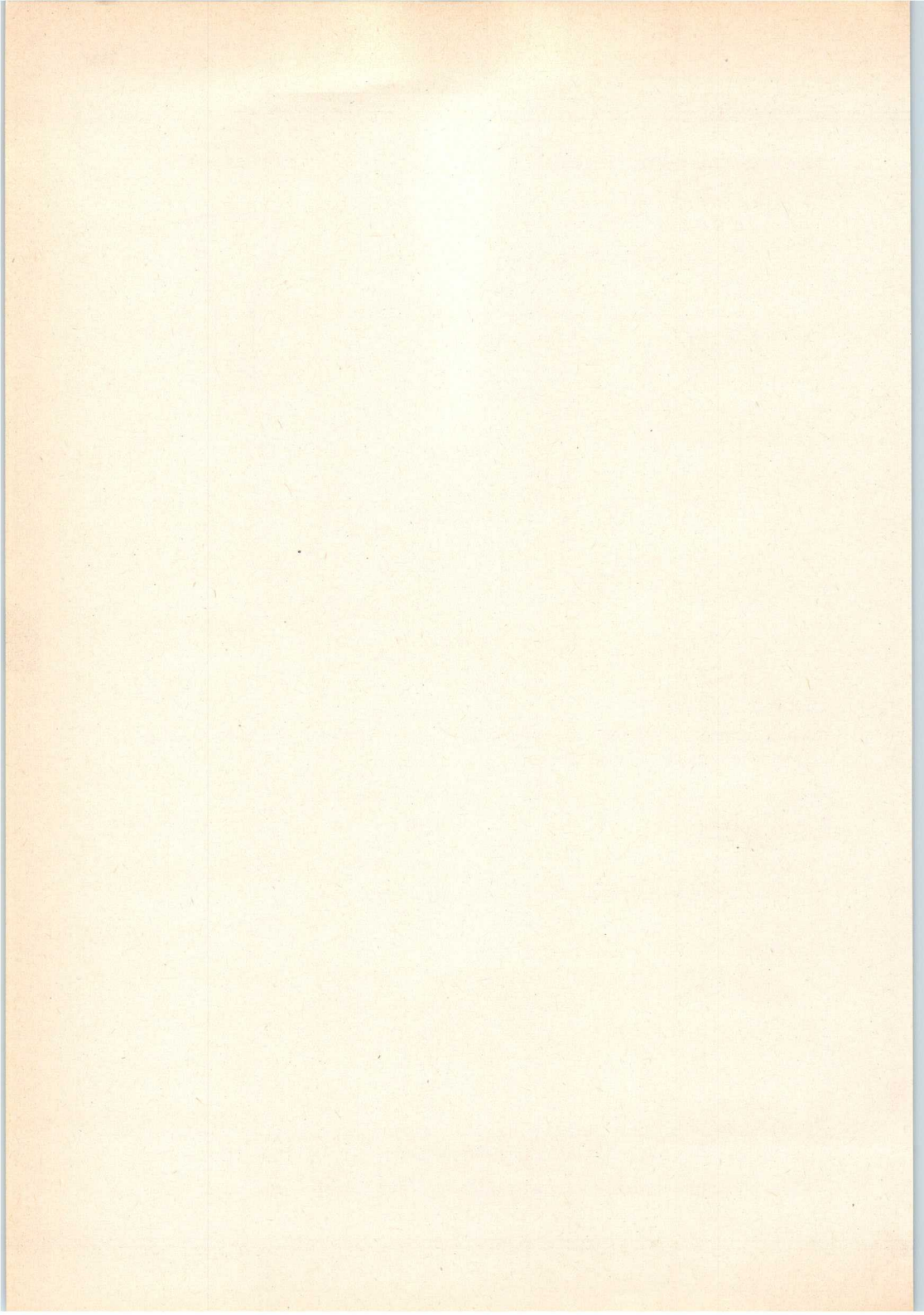

MONITOR TUBE

The M24-100W is a 24 cm-diagonal rectangular television tube with metal-backed screen primarily intended for use as a monitor or display tube.

QUICK REFERENCE DATA

Deflection angle	90 °
Focusing	electrostatic
Resolution	900 lines
Overall length	max. 260 mm

SCREEN

Metal-backed phosphor

Luminescence	white
Light transmission of face glass	52 %
Useful diagonal	min. 225 mm
Useful width	min. 190 mm
Useful height	min. 140 mm

HEATING

Indirect by a.c. or d.c.; parallel supply

Heater voltage	V_f	6,3	V
Heater current	I_f	300	mA

CAPACITANCES

Final accelerator to external conductive coating	$C_{g_3, g_5(l)}$	420	pF
Cathode to all other elements	C_k	5	pF
Control grid to all other elements	C_{g_1}	7	pF

FOCUSING

electrostatic

For focusing voltage providing optimum focus at a beam current of 100 μ A see under "Typical operating conditions".

DEFLECTION 3)

Diagonal deflection angle

MECHANICAL DATA

magnetic

90°

Dimensions in mm

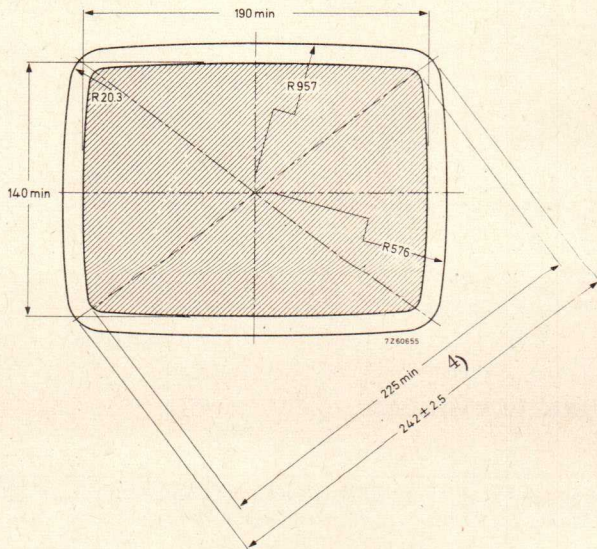
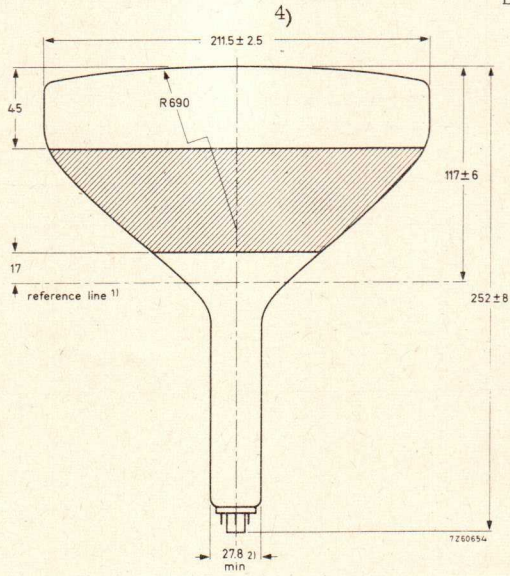

Notes see page 3

MECHANICAL DATA (continued)

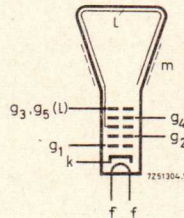
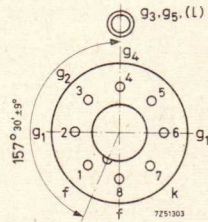
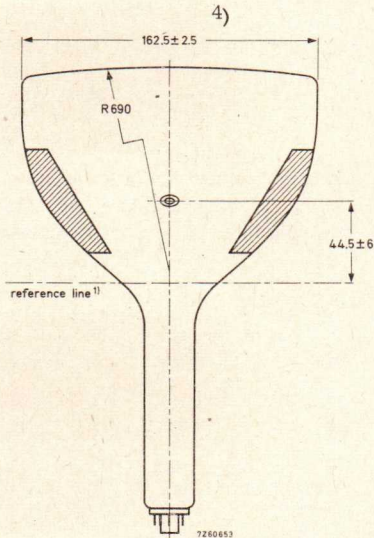

Mounting position : any, except vertical with the screen downward and the axis of the tube making an angle of less than 20° with the vertical.

Base

Neo eightar (B8H)

Cavity contact

CT8

Accessories

Socket

2422 501 06001

Final accelerator contact connector

type 55563A

PICTURE CENTRING MAGNET

Field intensity perpendicular to the tube axis adjustable from 0 to 800 A/m (0 to 10 Oe). Adjustment of the centring magnet should not be such that a general reduction in brightness or shading of the raster occurs.

NOTES

- 1) The reference line is determined by the plane of the upper edge of the of the flange of reference line gauge when the gauge is resting on the cone.
- 2) The maximum dimension is determined by the reference line gauge.
- 3) Deflection coil AT1071/01 is recommended. If another coil is considered, it is advisable to contact the local tube supplier.
- 4) The bulge at the spliceline seal may increase the indicated maximum values for envelope width, diagonal and height by not more than 6,4 mm, but at any point around the seal the bulge will not protrude more than 3,2 mm beyond the envelope surface.

MONITOR TUBE

The M24-101W is a 24 cm-diagonal rectangular television tube with integral protection primarily intended for use as a monitor or display tube.

QUICK REFERENCE DATA

Deflection angle	90 °	
Focusing	electrostatic	
Resolution	900	lines
Overall length	≤ 260	mm

SCREEN

Metal backed phosphor

Luminescence	white	
Light transmission of face glass	52	%
Useful diagonal	≥ 225	mm
Useful width	≥ 190	mm
Useful height	≥ 140	mm

HEATING

Indirect by a. c. or d. c.; parallel supply

Heater voltage	V_f	6.3	V
Heater current	I_f	300	mA

FOCUSING

electrostatic

For focusing voltage providing optimum focus at a beam current of 100 μ A see under "Typical operating conditions".

DEFLECTION

magnetic

Diagonal deflection angle	90 °
Horizontal deflection angle	80 °
Vertical deflection angle	65 °

Deflection coil AT1071/01 is recommended.

MECHANICAL DATA

Dimensions in mm

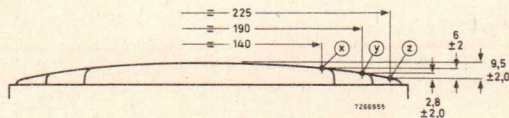
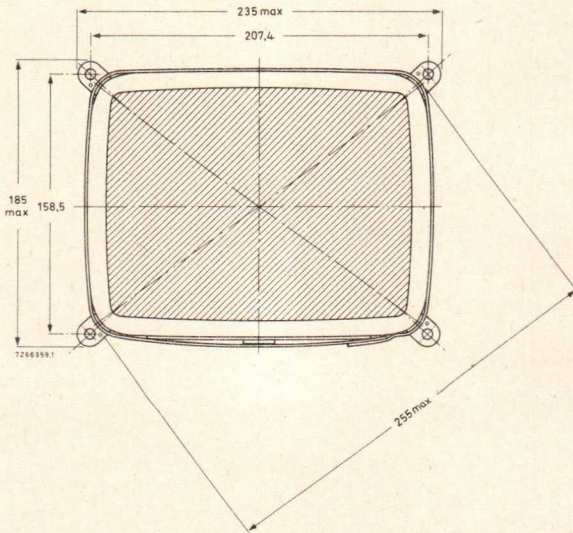
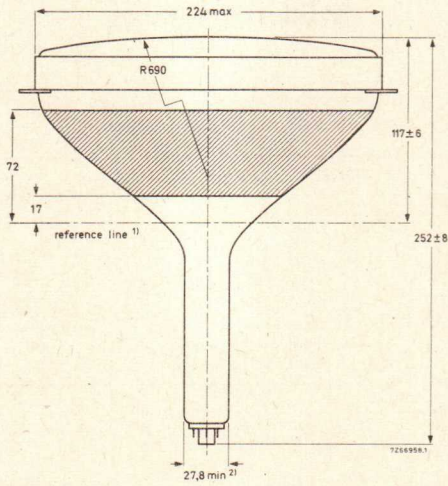

Notes see page 4.

MECHANICAL DATA (continued)

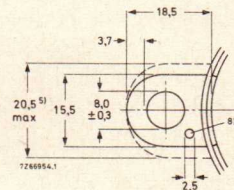
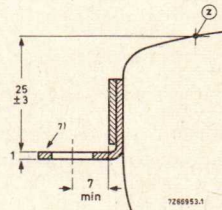
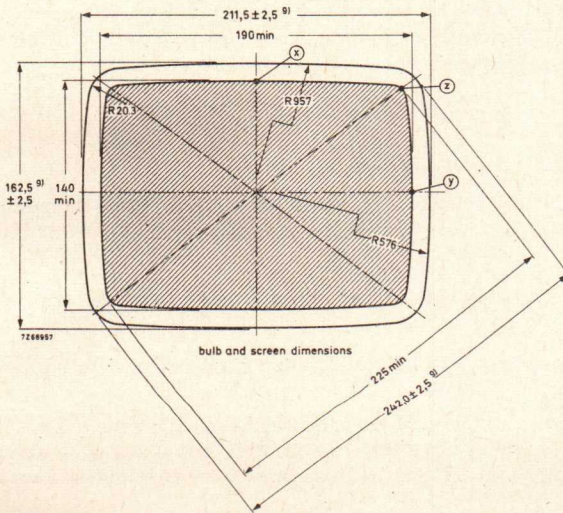
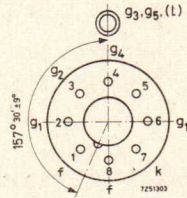
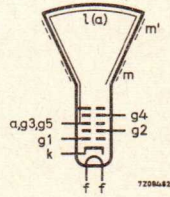
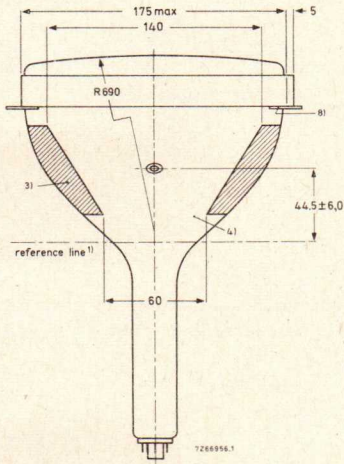

Notes see page 4.

MECHANICAL DATA (continued)

Mounting position : any

Base Neo eightar (B8H), IEC 67-I-31a

Cavity contact CT8, IEC67-III-2

Accessories

Socket 2422 501 06001

Final accelerator contact connector

PICTURE CENTRING MAGNET

Field intensity perpendicular to the tube axis adjustable from 0 to 800 A/m (0 to 10 Oe). Adjustment of the centring magnet should not cause a general reduction in brightness or shading of the raster.

NOTES TO OUTLINE DRAWINGS

- 1) The reference line is determined by the plane of the upper edge of the flange of the reference line gauge with the gauge resting on the cone.
- 2) The maximum dimension is determined by the reference line gauge.
- 3) This tube has an external conductive coating (m), which must be earthed. The capacitance of this coating to the final accelerator is used for smoothing the EHT. The tube marking and warning labels are on the side of the cone opposite the final accelerator contact, and this side should not be used for making contact to the conductive coating.
- 4) This area must be kept clean.
- 5) Minimum space to be reserved for mounting lugs.
- 6) The mounting screws in the cabinet must be situated within a circle with a diameter of 4 mm drawn around the true geometrical position (corners of a rectangle of 207,4 mm x 158,5 mm).
- 7) The maximum displacement of any lug with respect to the plane through the other three lugs is 2 mm.
- 8) The metal rim-band must be earthed. The hole of 2,5 mm diameter in each lug is provided for this purpose.
- 9) The bulge at the spliceline seal may increase the indicated maximum values for envelope width, diagonal and height by not more than 6,4 mm, but at any point around the seal the bulge will not protrude more than 3,2 mm beyond the envelope surface.

CAPACITANCES

Final accelerator to external conductive coating	$C_{g3, g5(\ell)}/m$	420	pF
Final accelerator to metal band	$C_{g3, g5(\ell)}/m'$	200	pF
Cathode to all other elements	C_k	5	pF
Control grid to all other elements	C_{g1}	7	pF

TYPICAL OPERATING CONDITIONS

Final accelerator voltage	$V_{g3, g5(\ell)}$	16	kV
Focusing electrode voltage	V_{g4} 0 to	400	V
First accelerator voltage	V_{g2}	600	V
Grid 1 voltage for extinction of focused raster	V_{g1} -32 to	-85	V

RESOLUTION

Resolution at screen centre measured with the shrinking raster method (non-interlaced raster), under typical operating conditions, and at a beam current of 50 μ A: 900 lines (luminance \approx 200 cd/m²).

If necessary, the picture quality can be improved by using a beam centring magnet. This magnet, catalogue number 3322 142 11401, can be supplied on request.

LIMITING VALUES (Absolute max. rating system)

Final accelerator voltage	$V_{g3, g5(\ell)}$	max. 18 min. 10	kV kV
Focusing electrode voltage, positive	V_{g4}	max. 1000	V
negative	$-V_{g4}$	max. 500	V
First accelerator voltage	V_{g2}	max. 800 min. 300	V V
Grid 1 voltage, negative	$-V_{g1}$	max. 150	V
positive	V_{g1}	max. 0	V
positive peak	V_{g1p}	max. 2	V
Cathode to heater voltage, positive	V_{kf}	max. 250	V
positive peak	V_{kfp}	max. 300	V ¹⁾
negative	$-V_{kf}$	max. 135	V
negative peak	$-V_{kfp}$	max. 180	V

¹⁾ During a warm-up period not exceeding 15 s the heater may be 410 V negative with respect to the cathode.

REFERENCE LINE GAUGE

Dimensions in mm

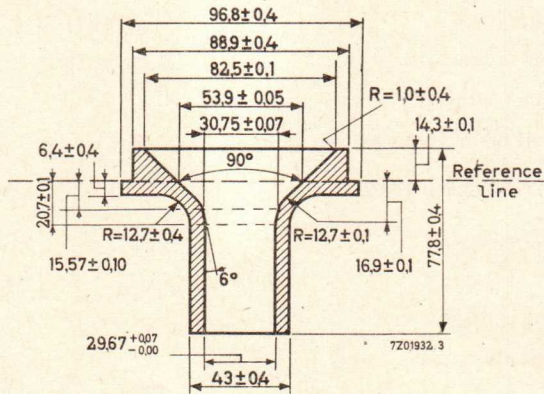

MONITOR TUBE

The M31-130W is a 31 cm-diagonal rectangular television tube with metal-backed screen primarily intended for use as a monitor or display tube.

QUICK REFERENCE DATA

Deflection angle	90°
Focusing	electrostatic
Resolution	900 lines
Overall length	max. 310 mm

SCREEN

Metal-backed phosphor

Luminescence	white
Light transmission of face glass	approx. 50 %
Useful diagonal	min. 295 mm
Useful width	min. 257 mm
Useful height	min. 195 mm

HEATING

Indirect by a.c. or d.c.; parallel supply

Heater voltage	V_f	6, 3	V
Heater current	I_f	300	mA

FOCUSING

electrostatic

For focusing voltage providing optimum focus at a beam current of 100 μ A see under "Typical operating conditions".

DEFLECTION

magnetic

Diagonal deflection angle	90°
---------------------------	-----

For a deflection coil please contact the local tube supplier.

MECHANICAL DATA

Dimensions in mm

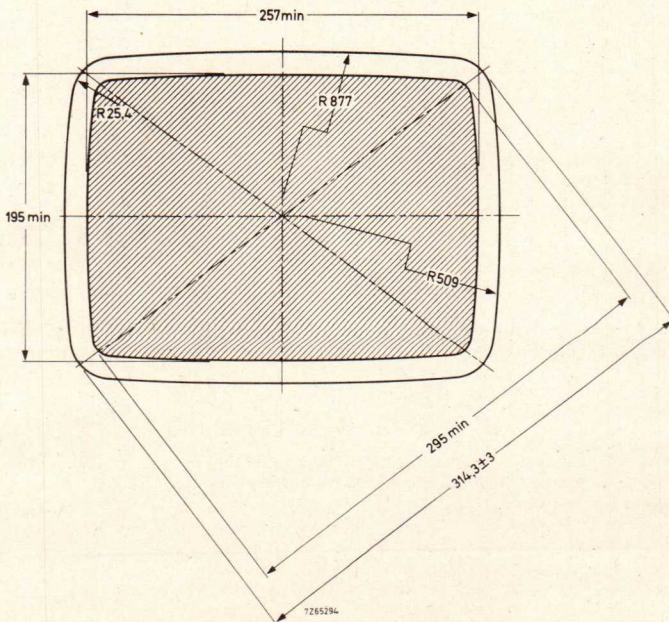
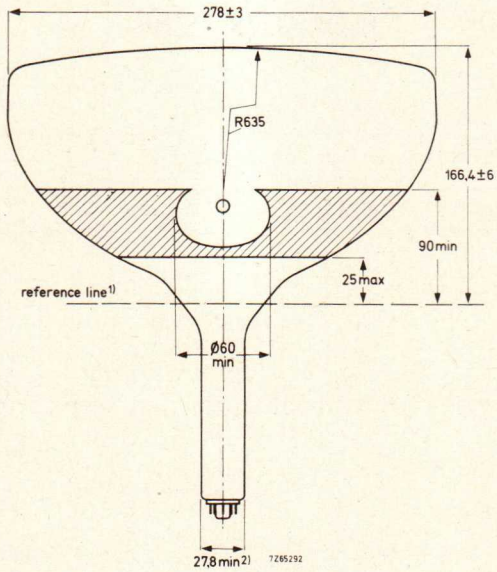

MECHANICAL DATA (continued)

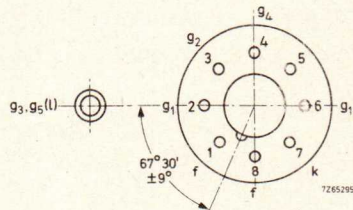
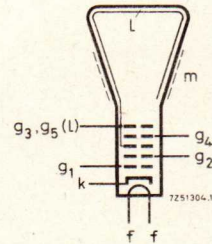
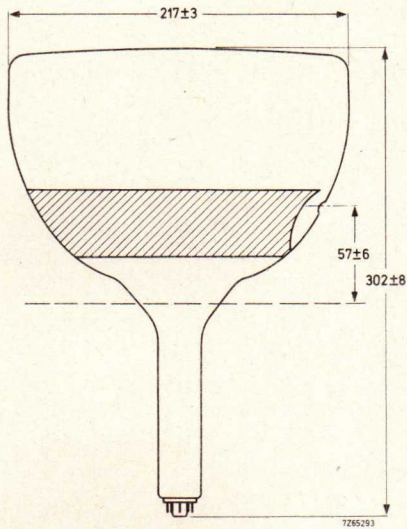

Mounting position: any, except vertical with the screen down and the axis of the tube making an angle of less than 20° with the vertical.

<u>Base</u>	Neo eightar (B8H), IEC67-I-31a
<u>Cavity contact</u>	CT8, IEC67-III-2
<u>Accessories</u>	
Socket	2422 501 06001
Final accelerator contact connector	type 55563A

CAPACITANCES

Final accelerator to external conductive coating	$C_{g3, g5(l)/m}$	1100 pF
Cathode to all other elements	C_k	5 pF
Control grid to all other elements	C_{g1}	7 pF

1) The reference line is determined by the plane of the upper edge of the flange of the reference line gauge with the gauge resting on the cone.

2) The maximum dimension is determined by the reference line gauge.

MONITOR TUBE

The M31-131W is a 31 cm-diagonal rectangular television tube with integral protection primarily intended for use as a monitor or display tube.

QUICK REFERENCE DATA

Deflection angle	90 °	
Focusing	electrostatic	
Resolution	900	lines
Overall length	≤ 310	mm

SCREEN

Metal backed phosphor

Luminescence	white	
Light transmission of face glass	approx. 50	%
Useful diagonal	≥ 295	mm
Useful width	≥ 257	mm
Useful height	≥ 195	mm

HEATING

Indirect by a.c. or d.c.; parallel supply

Heater voltage	V_f	6,3	V
Heater current	I_f	300	mA

FOCUSING

electrostatic

For focusing voltage providing optimum focus at a beam current of 100 μ A see under "Typical operating conditions".

DEFLECTION

magnetic

Diagonal deflection angle 90 °

For a deflection coil please contact the local tube supplier.

MECHANICAL DATA

Dimensions in mm

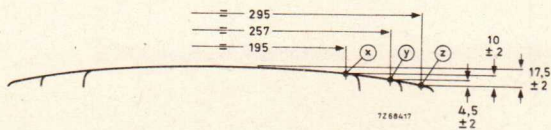
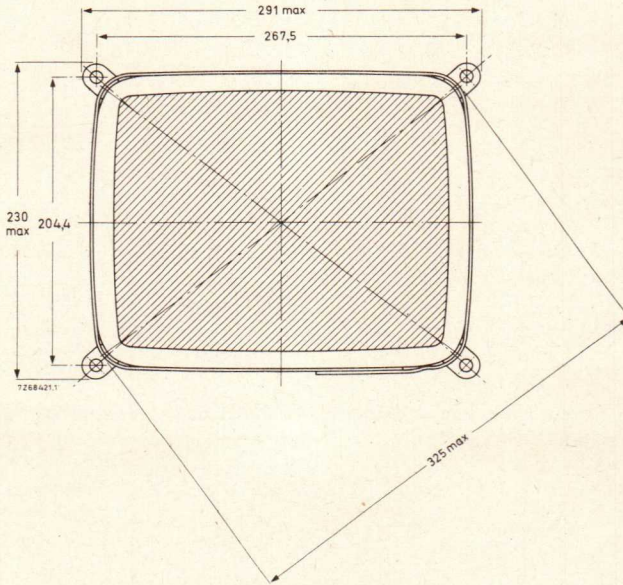
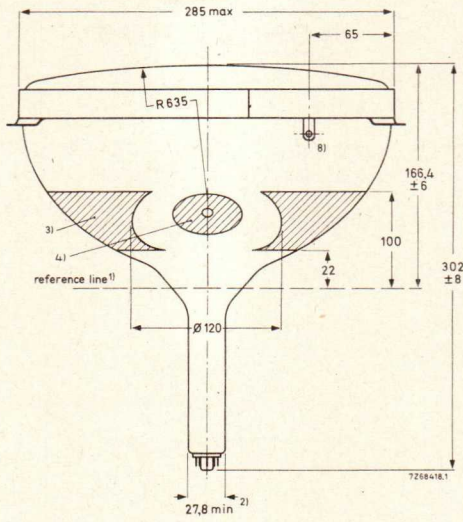

Notes see page 4

MECHANICAL DATA (continued)

Dimensions in mm

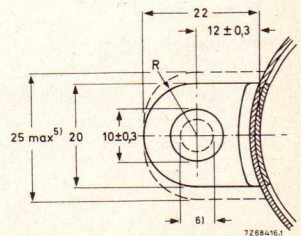
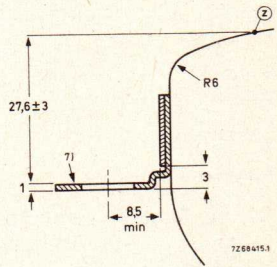
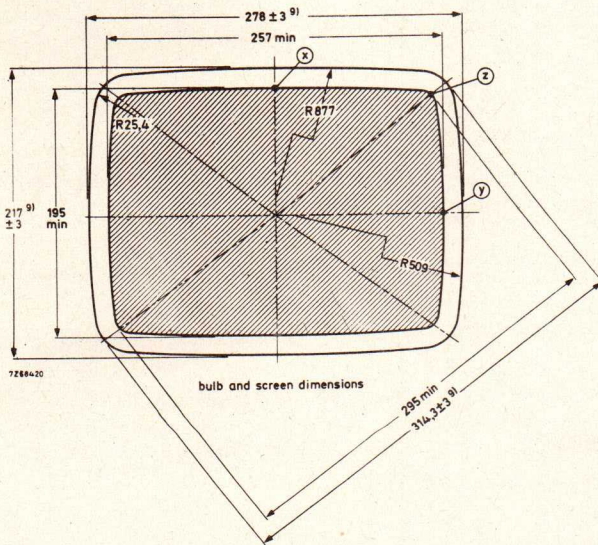
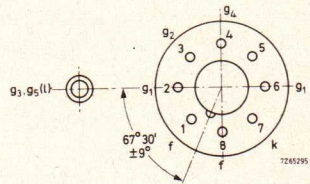
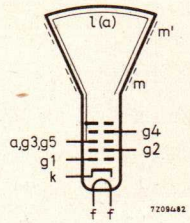
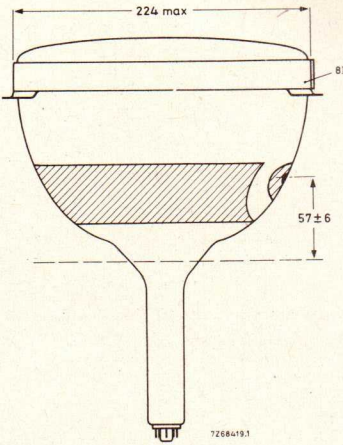

Notes see page 4

MECHANICAL DATA (continued)

Mounting position : anyBase

Neo eightar (B8H), IEC 67-I-31a

Cavity contact

CT8, IEC 67-III-2

Accessories

Socket

2422 501 06001

Final accelerator contact connector

type 55563A

PICTURE CENTRING MAGNET

Field intensity perpendicular to the tube axis adjustable from 0 to 800 A/m (0 to 10 Oe). Adjustment of the centring magnet should not cause a general reduction in brightness or shading the raster.

NOTES TO OUTLINE DRAWINGS

- 1) The reference line is determined by the plane of the upper edge of the flange of the reference line gauge with the gauge resting on the cone.
- 2) The maximum dimension is determined by the reference line gauge.
- 3) This tube has a external conductive coating (m), which must be earthed.
The capacitance of this coating to the final accelerator is used for smoothing the EHT.
The tube marking and warning labels are on the side of the cone opposite the final accelerator contact, and this side should not be used for making contact to the conductive coating.
- 4) This area must be kept clean.
- 5) Minimum space to be reserved for mounting lugs.
- 6) The mounting screws in the cabinet must be situated within a circle with a diameter of 6 mm drawn around the true geometrical position (corners of a rectangle of 267,5 mm x 204,4 mm).
- 7) The maximum displacement of any lug, with respect to the plane through the other three lugs is 2 mm.
- 8) The metal rim-band must be earthed. For this purpose the band is provided with a tag.
- 9) The bulge of the spliceline seal may increase the indicated maximum values for envelope width, diagonal, and height by not more than 6,4 mm, but at any point around the seal the bulge will not protrude more than 3,2 mm beyond the envelope surface.

CAPACITANCES

Final accelerator to external conductive coating	$C_{g3, g5(\ell)/m}$	1200	pF
Final accelerator to metal band	$C_{g3, g5(\ell)/m}$	150	pF
Cathode to all other elements	C_k	5	pF
Control grid to all other elements	C_{g1}	7	pF

TYPICAL OPERATING CONDITIONS

Final accelerator voltage	$V_{g3, g5(\ell)}$	16	kV
Focusing electrode voltage	V_{g4}	0 to 400	V
First accelerator voltage	V_{g2}	600	V
Grid 1 voltage for extinction of focused raster	V_{g1}	-32 to -85	V

RESOLUTION

Resolution at screen centre measured with the shrinking raster method (non-interlaced raster), under typical operating conditions, and at a beam current of 50 μ A: 900 lines

If necessary, the picture quality can be improved by using a beam centring magnet.

This magnet, catalogue number 3322 142 11401, can be supplied on request.

LIMITING VALUES (Absolute max. rating system)

Final accelerator voltage	$V_{g3, g5(\ell)}$	max.	18	kV	
		min.	10	kV	
Focusing electrode voltage, positive	V_{g4}	max.	1000	V	
	negative	$-V_{g4}$	max.	500	V
First accelerator voltage	V_{g2}	max.	800	V	
		min.	300	V	
Grid voltage, negative	$-V_{g1}$	max.	150	V	
	positive	V_{g1}	max.	0	V
	positive peak	V_{g1p}	max.	2	V
Cathode to heater voltage, positive	V_{kf}	max.	250	V	
	positive peak	V_{kfp}	max.	300	V
	negative	$-V_{kf}$	max.	135	V ¹⁾
	negative peak	$-V_{kfp}$	max.	180	V

1) During a warm-up period not exceeding 15 s the heater may be 410 V negative with respect to the cathode.

REFERENCE LINE GAUGE

Dimensions in mm

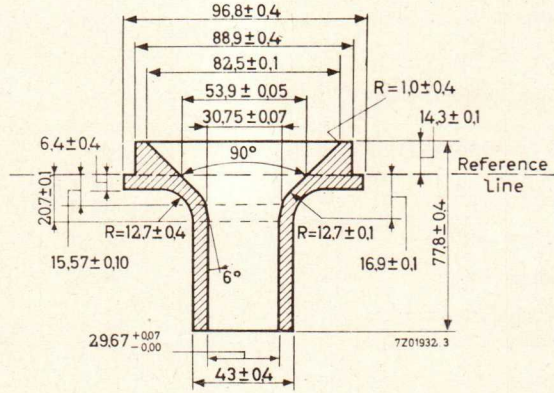

MONITOR TUBE

The M38-120W is a 38 cm-diagonal rectangular television tube with metal backed screen and integral protection primarily intended for use as a monitor tube. On request this tube can also be supplied with a WA screen phosphor.

QUICK REFERENCE DATA

Deflection angle	110°	
Focusing	electrostatic	
Resolution	min. 650	lines
Overall length	max. 279,5	mm

SCREEN

Metal backed phosphor

Luminescence	white	
Light transmission of face glass	50	%
Useful diagonal	min. 350	mm
Useful width	min. 290	mm
Useful height	min. 226	mm

HEATING

Indirect by a.c. or d.c.; parallel or series supply

Heater voltage	V_f	6,3	V
Heater current	I_f	300	mA

FOCUSING

electrostatic

For focusing voltage providing optimum focus at screen centre at a beam current of 100 μ A see under "Typical operating conditions".

DEFLECTION

magnetic

Diagonal deflection angle	110°
Horizontal deflection angle	93°
Vertical deflection angle	76°

MECHANICAL DATA (continued)

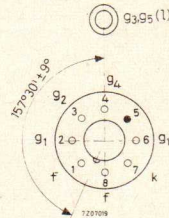
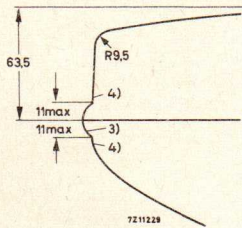
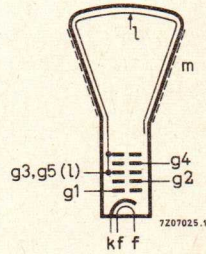
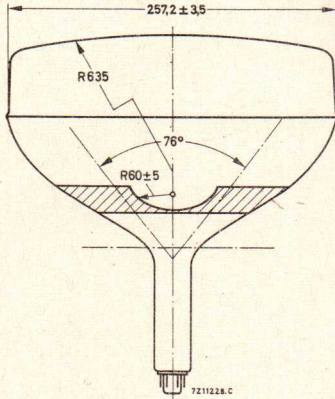

Mounting position: any

Base

Neo eightar (B8H), IEC67-I-31a

Cavity contact

CT8, IEC67-III-2

Accessories

Final accelerator contact connector

type 55563A

Socket

2422 501 06001

NOTES TO OUTLINE DRAWING

- 1) The reference line is determined by the plane of the upper edge of the flange of reference line gauge, (JEDEC 126) when the gauge is resting on the cone.
- 2) End of guaranteed contour. The maximum neck and cone contour is given by the Reference line gauge (see page 4).
- 3) Bulge at splice-line seal may increase the indicated maximum value for envelope width, diagonal and height by not more than 6,4 mm, but at any point around the seal, the bulge will not protrude more than 3,2 mm beyond the envelope surface at the location specified for dimensioning the envelope width, diagonal and height.
- 4) The tube should be supported on both sides of the bulge. The mechanism used should provide clearance for the maximum dimensions of the bulge.
- 5) The maximum dimension is determined by the reference line gauge

PICTURE CENTRING MAGNET

Field intensity perpendicular to the tube axis adjustable from 0 to 800 A/m (0 to 10 oersted). Adjustment of the centring magnet should not be such that a general reduction in brightness or shading of the raster occurs.

CAPACITANCE

Control grid to all other elements	C_{g1}	6,0	pF
Cathode to all other elements	C_k	5,0	pF
Final accelerator to external conductive coating	$C_{g3, g5(\ell)/m}$	600	pF

TYPICAL OPERATING CONDITIONS

Final accelerator voltage	$V_{g3, g5(\ell)}$	16	kV
Focusing electrode voltage	V_{g4}	0 to 400	V ¹⁾
First accelerator voltage	V_{g2}	400	V
Grid No. 1 voltage for visual extinction of a focused raster	$-V_{g1}$	40 to 85	V

RESOLUTION

Resolution at screen centre, measured with the shrinking raster method (non-interlaced raster), under typical operating conditions, a beam current of 100 μ A, and focusing voltage adjusted for optimum spot size

min.	650	lines
------	-----	-------

LIMITING VALUES (Absolute max. rating system)

Voltages are specified with respect to cathode unless otherwise stated.

Final accelerator voltage	$V_{g3, g5(\ell)}$	max.	18	kV
		min.	13	kV
Focusing electrode voltage	V_{g4}	max.	1	kV
	$-V_{g4}$	max.	0,5	kV
First accelerator voltage	V_{g2}	max.	550	V
		min.	350	V
Control grid voltage, negative	$-V_{g1}$	max.	150	V
positive	V_{g1}	max.	0	V
positive peak	V_{g1p}	max.	2	V
Cathode to heater voltage, positive	V_{kf}	max.	250	V
positive peak	V_{kfp}	max.	300	V
negative	$-V_{kf}$	max.	135	V
negative peak	$-V_{kfp}$	max.	180	V

¹⁾ With the small change in focus spot size with variation of focus voltage the limit of 0 to 400 V is such that an acceptable focus quality is obtained within this range. If it is required to pass through the point of focus, a voltage of at least -100 V to +500 V will be required.

CIRCUIT DESIGN VALUES

Focusing electrode current, positive	I_{g4}	max.	25	μA
negative	$-I_{g4}$	max.	25	μA
Grid no. 2 current, positive	I_{g2}	max.	5	μA
negative	$-I_{g2}$	max.	5	μA

MAXIMUM CIRCUIT VALUES

Resistance between cathode and heater	R_{kf}	max.	1	$\text{M}\Omega$
Impedance between cathode and heater ($f = 50 \text{ Hz}$)	Z_{kf}	max.	500	$\text{k}\Omega$
Resistance between grid no. 1 and earth	R_{g1}	max.	1,5	$\text{M}\Omega$
Impedance between cathode and earth ($f = 50 \text{ Hz}$)	Z_k	max.	100	$\text{k}\Omega$

WARNING

X-ray shielding is advisable to give protection against possible danger of personal injury arising from prolonged exposure at close range to this tube when operated above 16 kV.

EXTERNAL CONDUCTIVE COATING

This tube has an external conductive coating (m), which must be earthed and capacitance of this to the final electrode is used to provide smoothing for the EHT supply. The tube marking and warning labels are on the side of the cone opposite the final electrode connector and this side should not be used for making contact to the external conductive coating.

REFERENCE LINE GAUGE

Dimensions in mm

JEDEC 126

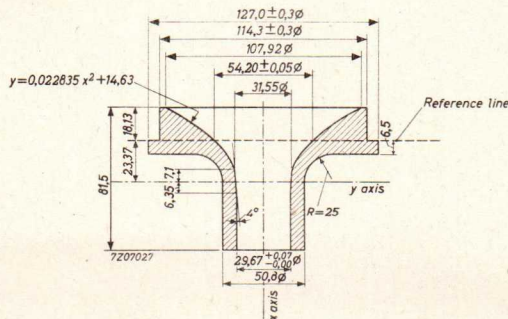

REMARK

With the high voltage used with this tube internal flash-overs may occur. These may destroy the cathode of the tube. Therefore it is necessary to provide protective circuits, using spark gaps.

The spark gaps must be connected as follows:

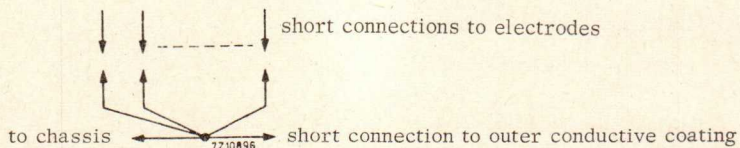

No other connections between the outer conductive coating and the chassis are permissible.

On request the tube can be supplied with spark traps mounted in the base (ring trap base).

MONITOR TUBE

The M38-121 is a 38 cm-diagonal rectangular television tube with metal backed screen and integral protection primarily intended for use as a monitor or display tube.

QUICK REFERENCE DATA

Deflection angle	110°	
Focusing	electrostatic	
Resolution	min. 650	lines
Overall length	max. 279,5	mm

SCREEN

Metal backed phosphor

Luminescence	white	
Light transmission of face glass	50	%
Useful diagonal	min. 350	mm
Useful width	min. 290	mm
Useful height	min. 226	mm

HEATING

Indirect by a. c. or d. c. ; parallel or series supply

Heater voltage	V_f	6,3	V
Heater current	I_f	300	mA

FOCUSING

electrostatic

For focusing voltage providing optimum focus at screen centre at a beam current of 100 μ A see under "Typical operating conditions".

DEFLECTION

magnetic

Diagonal deflection angle	110°
Horizontal deflection angle	93°
Vertical deflection angle	76°

MECHANICAL DATA

Dimensions in mm

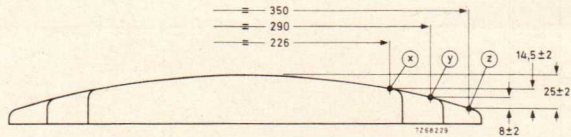
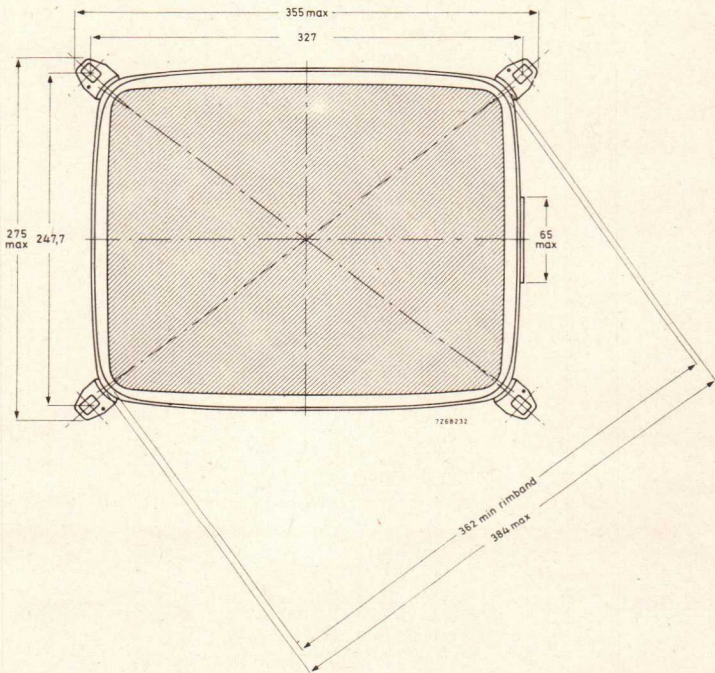
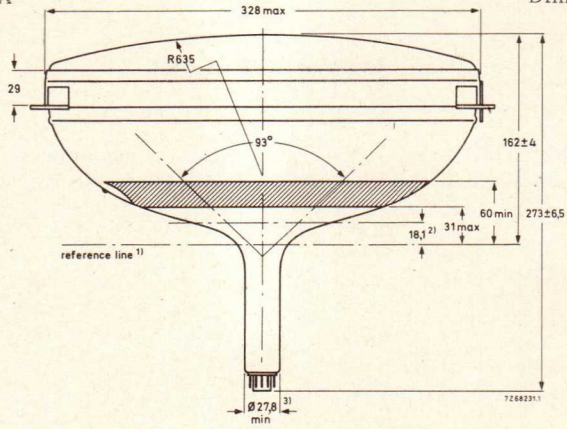

MECHANICAL DATA (continued)

Dimensions in mm

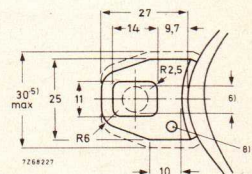
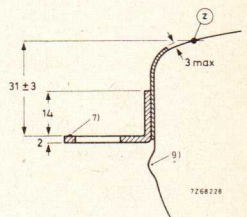
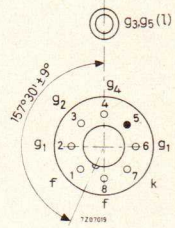
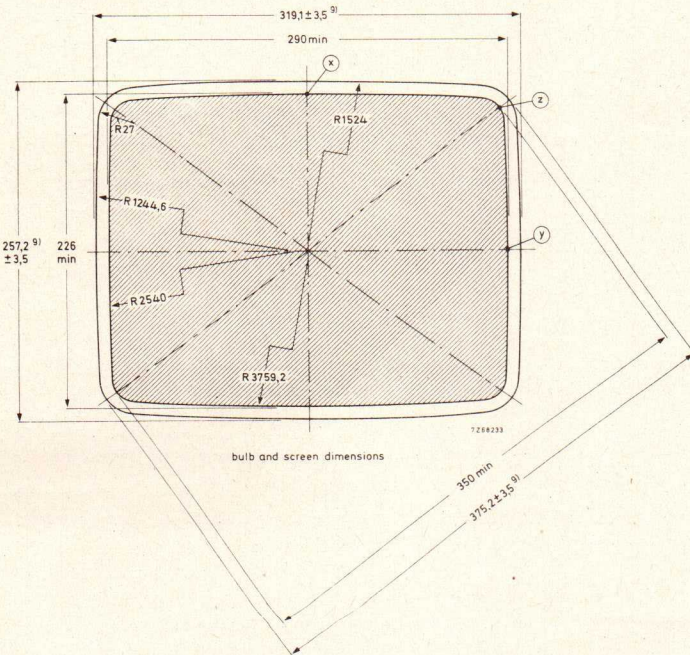
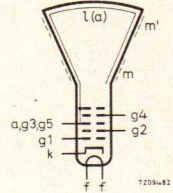
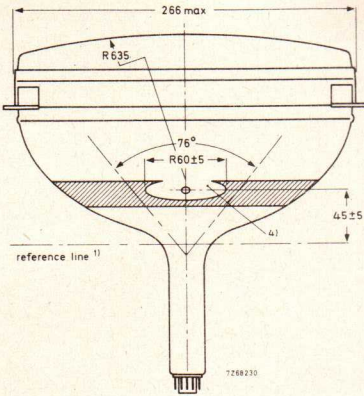

MECHANICAL DATA (continued)

Mounting position: anyBase Neo eightar (B8H), IEC67-1-31aCavity contact CT8, IEC67-III-2Accessories

Socket 2422 501 06001

Final accelerator contact connector type 55563

PICTURE CENTRING MAGNET

Field intensity perpendicular to the tube axis from 0 to 800 A/m (0 to 10 Oe). Adjustment of the centring magnet should not cause a general reduction in brightness or shading of the raster.

NOTES TO OUTLINE DRAWING

- 1) The reference line is determined by the plane of the upper edge of the flange of the reference line gauge, (JEDEC 126) when the gauge is resting on the cone.
- 2) End of guaranteed contour. The maximum neck and cone contour is given by the reference line gauge.
- 3) The maximum dimension is given by the reference line gauge.
- 4) This area must be kept clean.
- 5) Minimum space to be reserved for mounting lugs.
- 6) The mounting screws in the cabinet must be situated within a circle with a diameter of 7,5 mm drawn around the true geometrical positions (corners of a rectangle of 327 mm x 247,7 mm).
- 7) The maximum displacement of any lug with respect to the plane through the other three lugs is 2 mm.
- 8) The metal rimband must be earthed. Holes of 3 mm diameter in each lug are provided for this purpose.
- 9) The bulge at the pliceline seal may increase the indicated maximum value for envelope width, diagonal and height by not more than 6,4 mm, but at any point around the seal the bulge will not protrude more than 3,2 mm beyond the envelope surface.

CAPACITANCES

Final accelerator to external conductive coating	$C_{g3, g5(\ell)}/m$	450 to 650	pF
Final accelerator to metal band	$C_{g3, g58\ell 9}/m'$	240	pF
Cathode to all other elements	C_k	5	pF
Control grid to all other elements	C_{g1}	6	pF

TYPICAL OPERATING CONDITIONS

Final accelerator voltage	$V_{g3, g5(\ell)}$	16	kV
Focusing electrode voltage	V_{g4}	0 to 400	V ¹⁾
First accelerator voltage	V_{g2}	400	V
Grid No. 1 voltage for visual extinction of a focused raster	V_{g1}	40 to 85	V

RESOLUTION

Resolution at screen centre, measured with the shrinking raster method (non-interlaced raster), under typical operating conditions, a beam current of $100, \mu A$, and focusing voltage adjusted for optimum spot size

min. 650 lines

LIMITING VALUES (Absolute max. rating system)

Voltages are specified with respect to cathode unless otherwise stated.

Final accelerator voltage	$V_{g3, g5(\ell)}$	max. 18	kV
		min. 13	kV
Focusing electrode voltage	V_{g4}	max. 1000	V
	$-V_{g4}$	max. 500	V
First accelerator voltage	V_{g2}	max. 550	V
		min. 350	V
Control grid voltage, negative	$-V_{g1}$	max. 150	V
positive	V_{g1}	max. 0	V
positive peak	V_{g1p}	max. 2	V
Cathode to heater voltage, positive	V_{kf}	max. 250	V
positive peak	V_{kfp}	max. 300	V
negative	$-V_{kf}$	max. 135	V
negative peak	$-V_{kfp}$	max. 180	V

¹⁾ With the small change in focus spot size with variation of focus voltage the limit of 0 to 400 V is such that an acceptable focus quality is obtained within this range. If it is required to pass through the point of focus, a voltage range of at least -100 to +500 V will be required.

CIRCUIT DESIGN VALUES

Focusing electrode current, positive	I_{g4}	max.	25	μA
negative	$-I_{g4}$	max.	25	μA
Grid No. 2 current, positive	I_{g2}	max.	5	μA
negative	$-I_{g2}$	max.	5	μA

MAXIMUM CIRCUIT VALUES

Resistance between cathode and heater	R_{kf}	max.	1	$\text{M}\Omega$
Impedance between cathode and heater ($f = 50 \text{ Hz}$)	Z_{kf}	max.	500	$\text{k}\Omega$
Resistance between grid no. 1 and earth	R_{g1}	max.	1,5	$\text{M}\Omega$
Impedance between cathode and earth ($f = 50 \text{ Hz}$)	Z_k	max.	100	$\text{k}\Omega$

WARNING

X-ray shielding is advisable to give protection against possible danger of personal injury arising from prolonged exposure at close range to this tube when operated above 16 kV.

EXTERNAL CONDUCTIVE COATING

This tube has an external conductive coating (m), which must be earthed and capacitance of this to the final electrode is used to provide smoothing for the EHT supply. The tube marking and warning labels are on the side of the cone opposite the final electrode connector and this side should not be used for making contact to the external conductive coating.

REFERENCE LINE GAUGE

Dimensions in mm

JEDEC 126

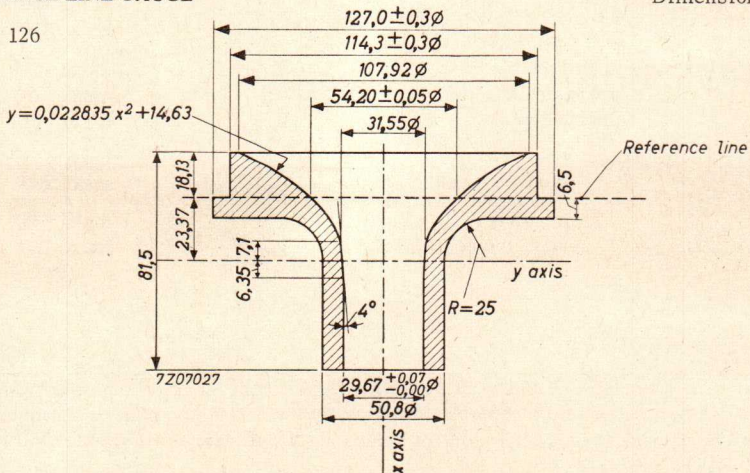

REMARK

With the high voltage used with this tube internal flash -overs may occur. These may destroy the cathode of the tube. Therefore it is necessary to provide protective circuits, using spark gaps.

The spark gaps must be connected as follows:

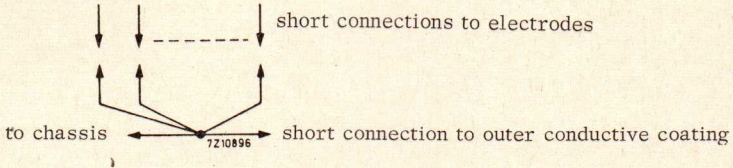

No other connections between the outer conductive coating and the chassis are permissible.

On request the tube can be supplied with spark traps mounted in the base (ring trap base).



C-R tubes for special applications



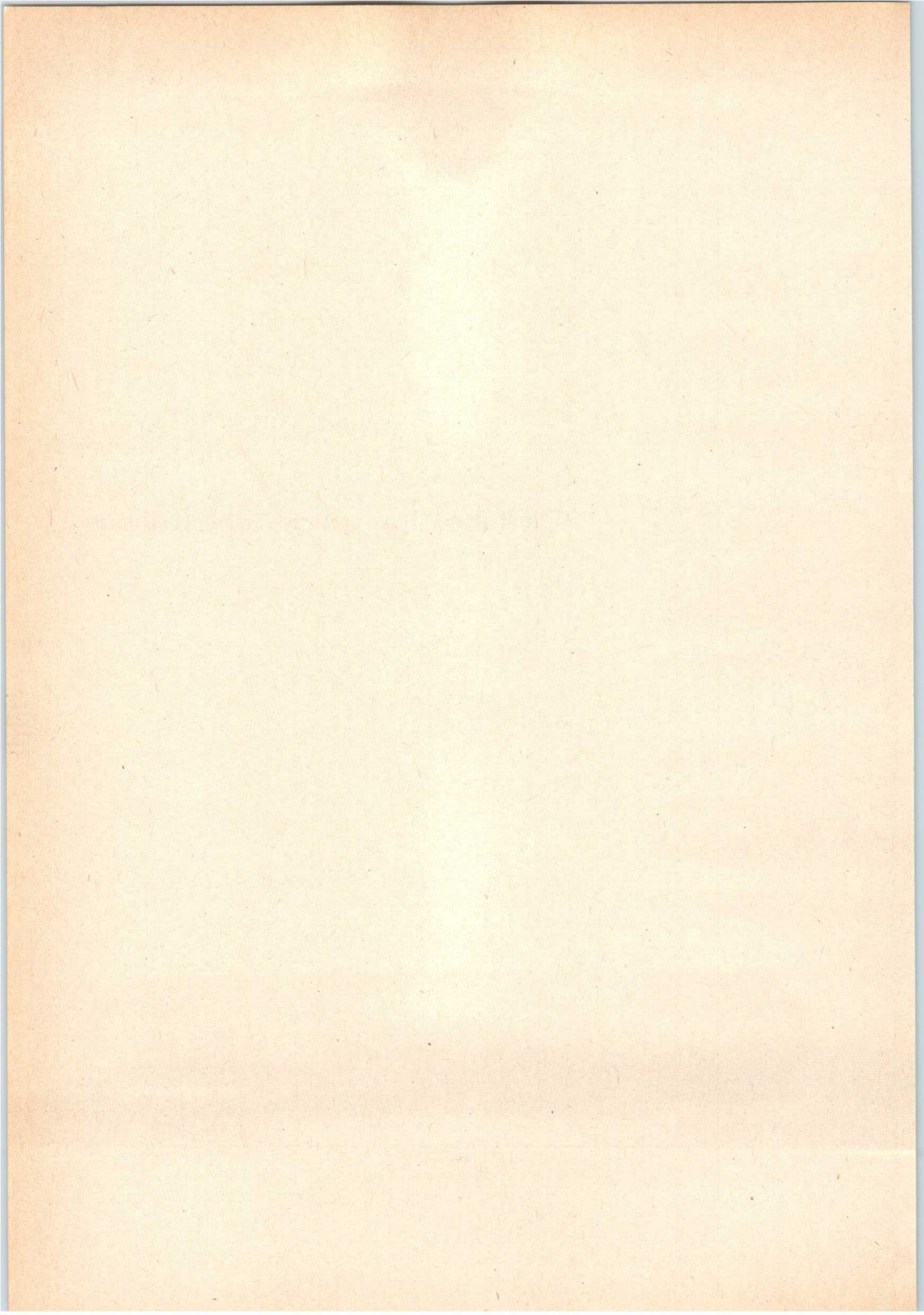

PROJECTION TUBE

The M. 13-38 is a 13 cm diameter projection tube designed for large screen projection of colour TV displays.

QUICK REFERENCE DATA

Final accelerator voltage	$V_{g2(\ell)}$	50	kV
Deflection angle		47	deg
Focusing			magnetic

SCREEN

Type	MG13-38	MU13-38	MY13-38
Colour	green	blue	red
Colour point	$x = 0,19 \quad y = 0,72$	$x = 0,17 \quad y = 0,13$	$x = 0,66 \quad y = 0,33$
Useful screen area			$92 \times 69 \text{ mm}^2$

Luminance

MG13-38	2000	mcd/cm ²
MU13-38	290	mcd/cm ²
MY13-38	600	mcd/cm ²

measured at $V_{g2(\ell)} = 50 \text{ kV}$; $I_{\ell} = 500 \mu\text{A}$, raster size $92 \text{ mm} \times 69 \text{ mm}$

HEATING

Indirect by a. c. or d. c. ; parallel series supply

Heater voltage	V_f	6,3	V
Heater current	I_f	300	mA

CAPACITANCES

Control grid to all other elements	C_{g1}	< 10	pF
Cathode to all other elements	C_k	< 9	pF

MECHANICAL DATA

Dimensions in mm

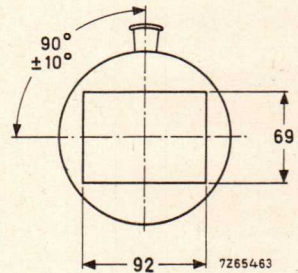
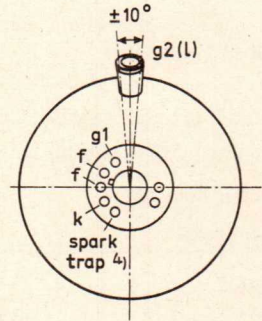
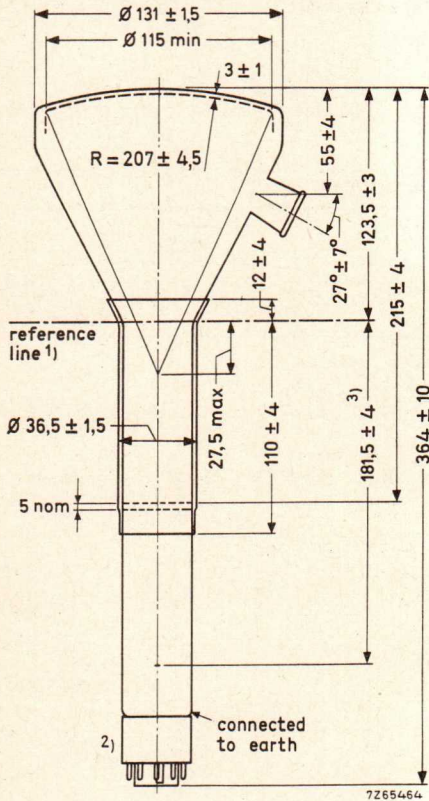

- 1) The reference line is determined by the position where a gauge 38,1 $\begin{matrix} +0,05 \\ -0,00 \end{matrix}$ mm diameter and 50 mm long will rest on the cone of the envelope.
- 2) The socket for this base should not be rigidly mounted; it should have flexible leads and be allowed to move freely. The bottom circumference of the base shell will fall within a circle with a diameter of 50 mm concentric with the cone axis.
- 3) Distance reference line to top-centre of grid.
- 4) This pin must be connected to earth.

MECHANICAL DATA (continued)

Mounting position: any, except screen downwards with the axis at an angle of less than 50° to the vertical.

The tube should not be supported by the base alone and under no condition should the socket be allowed to support the tube.

Base

Duodecal 7 p

Dimensions and connections

Overall length

max. 374 mm

Face diameter

max. 132,5 mm

Net weight

approx. 950 g

Accessories

Socket

type 5912/20

Final accelerator contact connector

supplied with tube

FOCUSING magnetic

Distance from the centr of the air gap of the focusing coil to the front of the screen
240 mm

DEFLECTION double magnetic
deflection angle 47°

TYPICAL OPERATING CONDITIONS

Accelerator voltage

 $V_{g2}^{(l)}$ 50 kVControl grid voltage for visual
extinction of a focused raster V_{g1} -100 to -100 V

Peak accelerator current

 I_{g2p} min. 2500 μ A

LIMITING VALUES (Absolute max. rating system)

Measured with respect to cathode

Accelerator voltage	$V_{g2}(\ell)$	max.	55	kV
		min.	40	kV
Control grid voltage,				
negative	$-V_{g1}$	max.	200	V
positive	V_{g1}	max.	0	V
positive peak	V_{g1p}	max.	0	V
Accelerator current	$I_{g2}(\ell)$	max.	500	μA ¹⁾
Cathode to heater voltage,				
cathode positive	V_{kf}	max.	100	V ²⁾
cathode negative	$-V_{kf}$	max.	50	V
Resistance between heater and cathode	R_{kf}	max.	20	$\text{k}\Omega$
Resistance between grid no. 1 and earth	R_{g1}	max.	1,5	$\text{M}\Omega$
Impedance between grid no. 1 and earth (f = 50 Hz)	Z_{g1}	max.	0,5	$\text{M}\Omega$

¹⁾ To prevent the possible occurrence of cracked faces the accelerator should be kept lower than the indicated value for images with concentrated bright areas (high screen loads). This applies particularly for stationary pictures.

²⁾ To avoid excessive hum, the A.C. component of the heater to cathode voltage should be as low as possible and must not exceed a r.m.s. value of 20 V.

GENERAL OBSERVATIONS

It is essential that means be provided for the instantaneous removal of the beam current if either one or both time-bases should fail. Unless such a safety device is incorporated, a failure of this type will immediately destroy the screen of the tube.

Shielding, equivalent to a lead thickness of 1 mm, is required to protect the observer against X-radiation.

The raster dimensions should not come below the minimum of $92 \times 69 \text{ mm}^2$.

The screen shall be given adequate cooling by exposure to a continuous airblast of approx. $0,06 \text{ m}^3/\text{s}$.

To prevent damage to the tube caused by a momentary internal arc, a resistor of $50 \text{ k}\Omega$ must be connected between the anode contact and the power supply.

Before removing the tube, the screen and the cone should be discharged.

The spark trap and the outer coating of the tube must be connected to earth.

It is recommend to use the E.H.T. connector supplied with each tube.

It is necessary to centre the focusing coil for optimum sharpness.



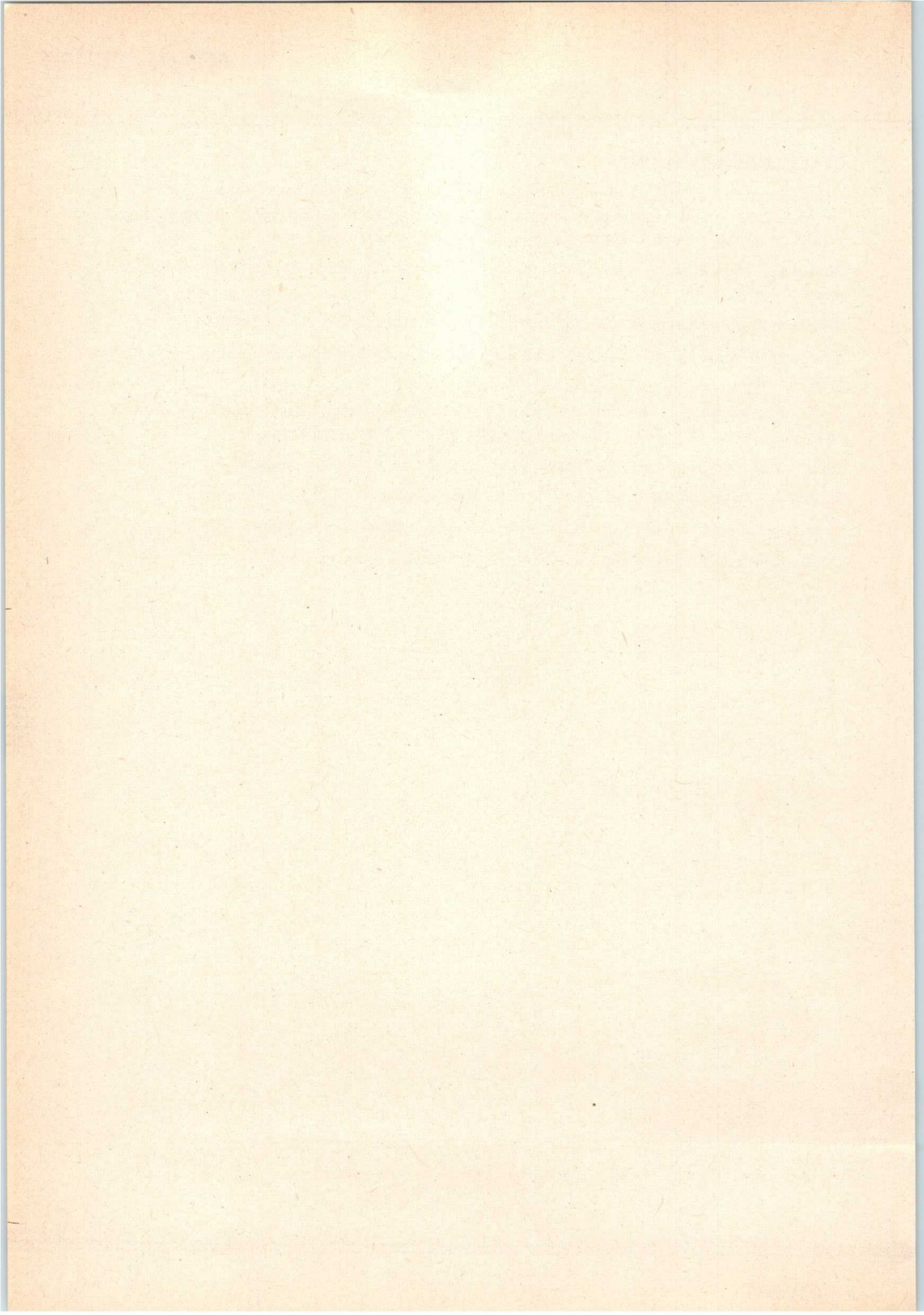

PROJECTION TUBE

The MW13-38 is a 13 cm diameter projection tube designed for large screen projection of TV displays.

QUICK REFERENCE DATA

Final accelerator voltage	$V_{g2(\ell)}$	50	kV
Deflection angle		47	deg
Focusing			magnetic

SCREEN

Metal backed

Colour white

Useful screen area 92 x 69 mm²

Luminance 870 mcd/cm²

measured at $V_{g2(\ell)} = 50$ kV

$I_{\ell} = 500$ μ A

raster size 92 x 69 mm²

HEATING

Indirect by a. c. or d. c. ; parallel series supply

Heater voltage V_f 6,3 V

Heater current I_f 300 mA

CAPACITANCES

Control grid to all other elements C_{g1} < 10 pF

Cathode to all other elements C_k < 9 pF

MECHANICAL DATA

Dimensions in mm

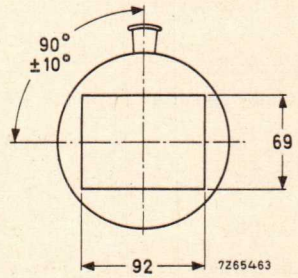
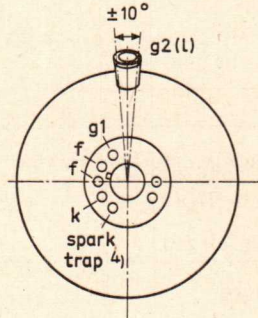
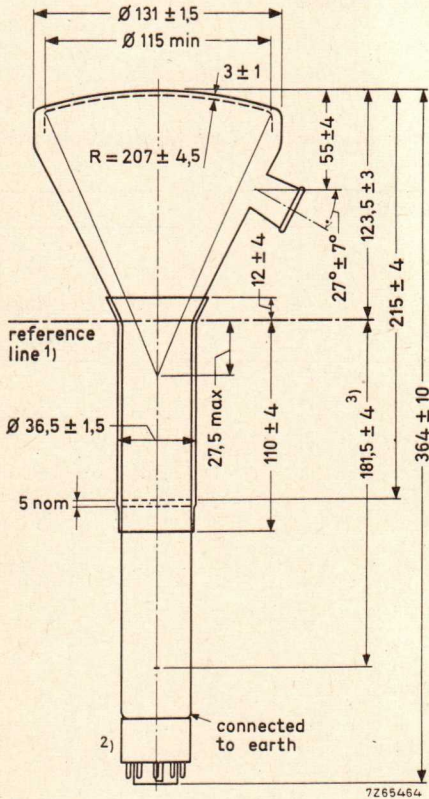

- 1) The reference line is determined by the position where a gauge $38,1^{+0,05}_{-0,00}$ mm diameter and 50 mm long will rest on the cone of the envelope.
- 2) The socket for this base should not be rigidly mounted; it should have flexible leads and be allowed to move freely. The bottom circumference of the base shell will fall within a circle with a diameter of 50 mm concentric with the cone axis.
- 3) Distance reference line to top-centre of grid.
- 4) This pin must be connected to earth.

MECHANICAL DATA (continued)

Mounting position: any, except with screen downwards with the axis at an angle of less than 50° to the vertical.

The tube should not be supported by the base alone and under no circumstances should the socket be allowed to support the tube.

<u>Base</u>	Duodecal 7 p
<u>Dimensions and connections</u>	
Overall length	max. 374 mm
Face diameter	max. 132,5 mm
<u>Net weight</u>	approx. 950 g
<u>Accessories</u>	
Socket	type 5912/20
Final accelerator contact connector	supplied with tube

FOCUSING magnetic

Distance from the centre of the air gap of the focusing coil to the front of the screen: 240 mm

DEFLECTION double magnetic
deflection angle 47° **TYPICAL OPERATING CONDITIONS**

Accelerator voltage	$V_{g2}(\ell)$	50	kV
Control grid voltage for visual extinction of focused raster	V_{g1}	-100 to -170	V
Peak accelerator current	$I_{g2(\ell)_p}$	min. 2500	μA

LIMITING VALUES (Absolute max. rating system)

Measured with respect to cathode

Accelerator voltage	$V_{g2(\ell)}$	max.	55	kV
		min.	40	kV
Control grid voltage,				
negative	$-V_{g1}$	max.	200	V
positive	V_{g1}	max.	0	V
positive peak	V_{g1p}	max.	0	V
Accelerator current	$I_{g2(\ell)}$	max.	500	μA ¹⁾
Cathode to heater voltage,				
cathode positive	V_{kf}	max.	100	V
cathode negative	$-V_{kf}$	max.	50	V ²⁾
Resistance between heater and cathode	R_{kf}	max.	20	$k\Omega$
Resistance between grid no. 1 and earth	R_{g1}	max.	1,5	$M\Omega$
Impedance between grid no. 1 and earth (f = 50 Hz)	Z_{g1}	max.	0,5	$M\Omega$

- 1) To prevent the possible occurrence of cracked faces, the accelerator current should be kept lower than the indicated value for images with concentrated bright areas (high screen loads). This applies particularly for stationary pictures.
- 2) To avoid excessive hum, the A.C. component of the heater to cathode voltage should be as low as possible and must not exceed a r.m.s. value of 20 V.

GENERAL OBSERVATIONS

It is essential that means be provided for the instantaneous removal of the beam current if either one or both time-bases should fail. Unless such a safety device is incorporated, a failure of this type will immediately destroy the screen of the tube.

Shielding, equivalent to a lead thickness of 1 mm, is required to protect the observer against X-radiation.

The raster dimensions should not come below the minimum of $92 \times 69 \text{ mm}^2$.

The screen shall be given adequate cooling by exposure to a continuous airstream of approx. $0,06 \text{ m}^3/\text{s}$.

To prevent damage to the tube caused by a momentary internal arc, a resistor of $50 \text{ k}\Omega$ must be connected between the anode contact and the power supply.

Before removing the tube, the screen and the cone should be discharged.

The spark trap and the outer coating of the tube must be connected to earth.

It is recommended to use the E.H.T. connector supplied with each tube.

It is necessary to centre the focusing coil for optimum sharpness.

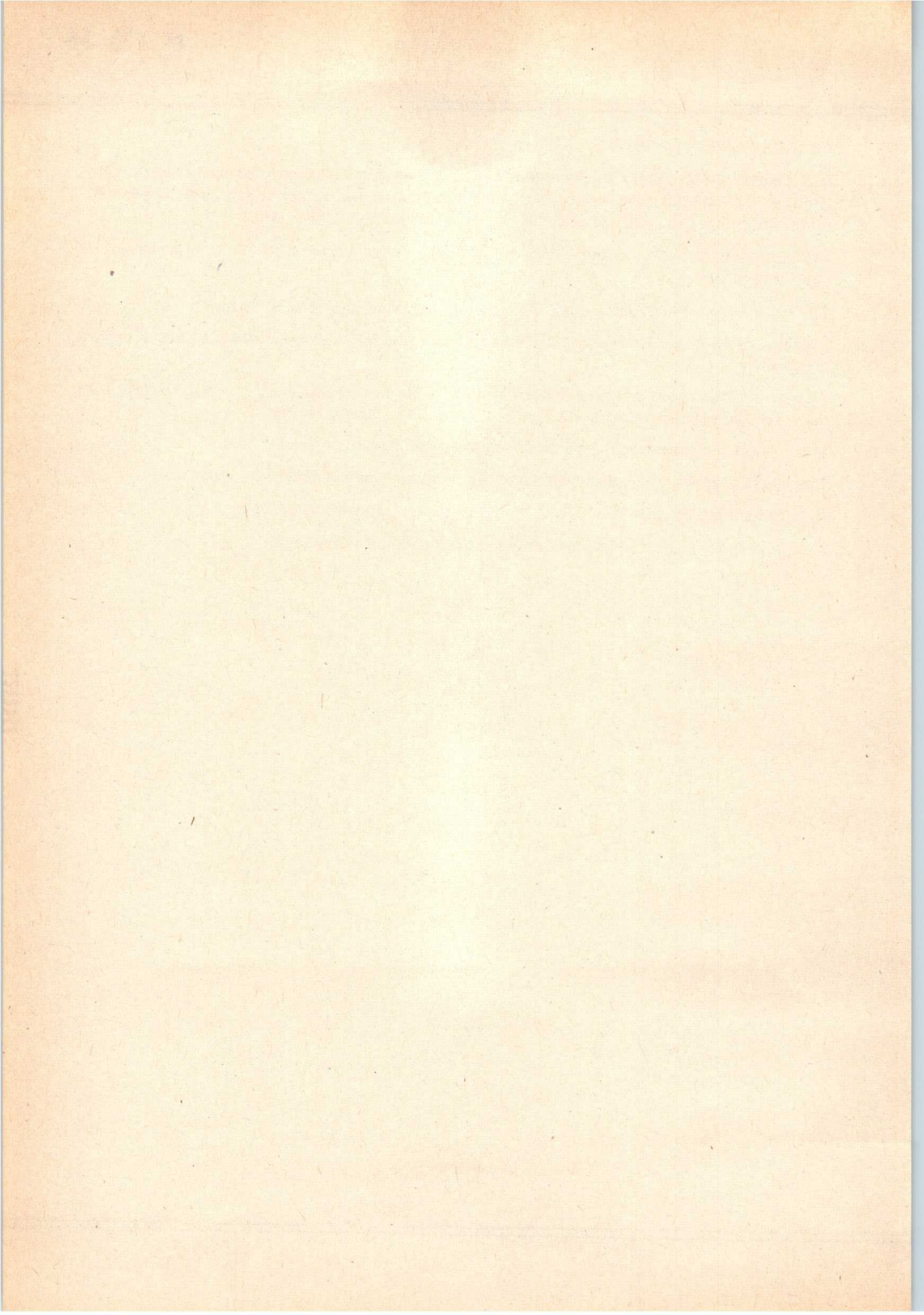

FLYING SPOT SCANNER TUBE

The Q7-100GU is an 7 cm diameter cathode-ray tube intended for flying spot scanner applications.

QUICK REFERENCE DATA

Final accelerator voltage	16	kV
Deflection angle	36	deg
Resolution	400	lines

SCREEN

Metal -backed phosphor

	Colour	Persistence
Q7-100GU	White	Very short

Useful screen diameter min. 60 mm

HEATING : indirect, by a.c. or d.c.; parallel supply

Heater voltage	V_f	6,3	V
Heater current	I_f	300	mA

CAPACITANCES

Grid no.1 to all other electrodes	C_{g1}	7,5	pF
Cathode to all other electrodes	C_k	5,5	pF
Final accelerator to outer conductive coating	$C_{g3, l / m}$	300	pF

FOCUSING

electrostatic

DEFLECTION

magnetic

Deflection angle 36 deg

ACCESSORIES

Final accelerator contact connector	type	55563A
Insulating cap	provided with tube	

MECHANICAL DATA

Dimensions in mm

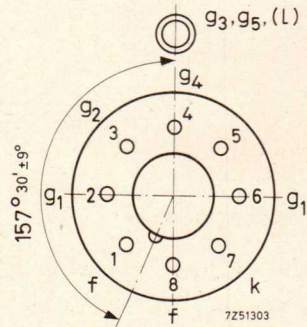
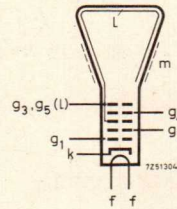
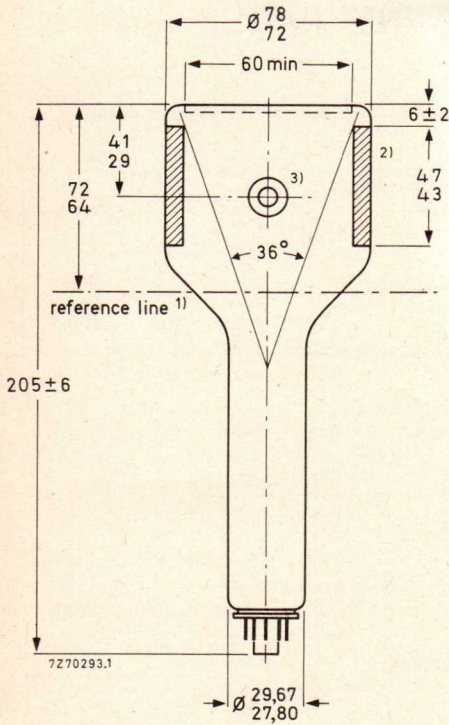

Mounting position : any, except with the screen downwards and the axis of the tube at an angle of less than 20° to vertical.

Base : Neo eighttar, B8-H ; IEC67-I-31a

Net mass : ≈ 180 g

1) Reference line determined by the plane of the upper edge of the reference line gauge when the gauge is resting on the cone.

2) The outer conductive coating must be earthed.

3) Recessed cavity contact CT8 ; IEC67-III-2

REFERENCE LINE GAUGE

IEC67-IV-3, JEDEC 126

TYPICAL OPERATION

Final accelerator voltage	$V_{g3, g5, l}$	16	kV
Focusing electrode voltage	V_{g4}	0 to 600	V ¹⁾
First accelerator voltage	V_{g2}	600	V
Grid no. 1 voltage for visual extinction of a focused raster	V_{g1}	-32 to -85	V

RESOLUTION

Resolution at screen centre, measured with the shrinking raster method, non-interlaced raster, under typical operating conditions, a beam current of 50 μ A, focusing voltage adjusted for optimum spot size

400 lines

¹⁾ To obtain optimum focus at the centre of the screen with a beam current of 50 μ A. If it is required to pass through the point of focus, a voltage range of -100 V to +700V may be required.

LIMITING VALUES (Absolute max. rating system)

Final accelerator voltage	$V_{g3, g5, l}$	max. 18 min. 12	kV kV	¹⁾
Focusing electrode voltage	V_{g4}	max. 1 min. 0,5	kV kV	
First accelerator voltage	V_{g2}	max. 800 min. 300	V V	
Cathode to heater voltage, positive	V_{kf}	max. 250	V	
positive peak	V_{kf_p}	max. 300	V	²⁾
negative	$-V_{kf}$	max. 135	V	
negative peak	$-V_{kf_p}$	max. 180	V	

WARNING

X-ray shielding is advisable to give protection against possible danger of personal injury arising from prolonged exposure at close range to this tube.

¹⁾ These voltages are only permissible when use is made of the insulating cap, provided with the tube. This cap should be inserted between tube and deflection coil.
Without cap $V_{g3, g5, l}$ is max. 13 kV.

²⁾ During a warm-up period not exceeding 15 s the heater may be 410 V negative with respect to the cathode.

FLYING SPOT SCANNER TUBE

The Q13-110.. is a 13 cm diameter cathode-ray tube intended for flying spot applications.

QUICK REFERENCE DATA

Accelerator voltage	25 kV
Deflection angle	40°
Resolution	1000 lines

SCREEN

Metal backed

	Colour	Persistence
Q13-110BA	Purplish blue	Very short
Q13-110GU	White	Very short

Useful screen diameter min. 108 mm

HEATING

Indirect by A.C. or D.C.; series or parallel supply

Heater voltage	V_f	6.3 V
Heater current	I_f	300 mA

CAPACITANCES

Grid No.1 to all other electrodes	C_{g1}	6.5 pF
Cathode to all other electrodes	C_k	6.5 pF
Accelerator to outer conductive coating	$C_{g2(\ell)/m}$	250 to 450 pF

MECHANICAL DATA

Dimensions in mm

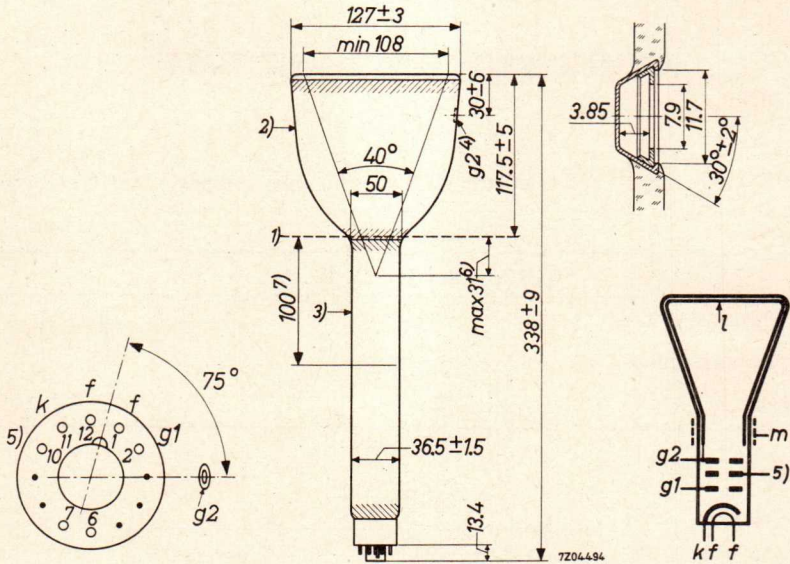

Mounting position: any, except with screen downwards and the axis of the tube making an angle of less than 50° with the vertical.

Base Duodecal 7p.

- 1) Reference line, determined by the plane of the upper edge of the reference line gauge when the gauge is resting on the cone.
- 2) Insulating outer coating; should not be in close proximity to any metal part.
- 3) Conductive outer coating; to be grounded.
- 4) Recessed cavity contact.
- 5) Spark trap; to be grounded.
- 6) The distance between the deflection centre and the reference line should not exceed 31 mm.
- 7) Distance between the centre of the magnetic length of the focusing unit and the reference line.

FOCUSING magnetic

Focusing coil type AT1997

DEFLECTION magnetic

REFERENCE LINE GAUGE

Dimensions in mm

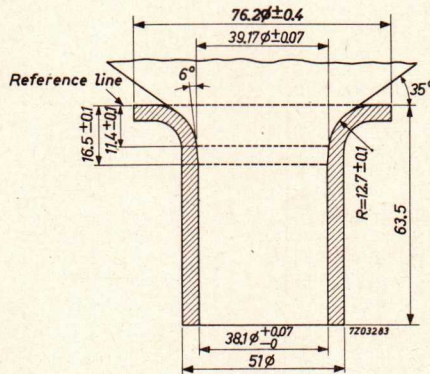

OPERATING CHARACTERISTICS

Accelerator voltage	$V_{g2(l)}$	25 kV
Beam current	I_l	50 to 150 μ A
Negative grid No.1 cut-off voltage	$-V_{g1}(I_l=0)$	50 to 100 V
Resolution at centre of screen better than 1000 lines	1)	

1) With focusing coil AT1997

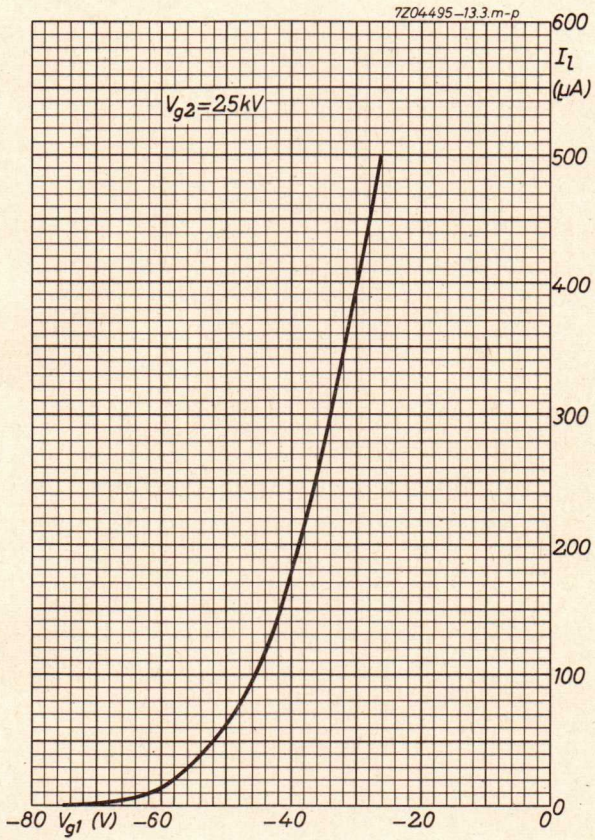

Associated accessories



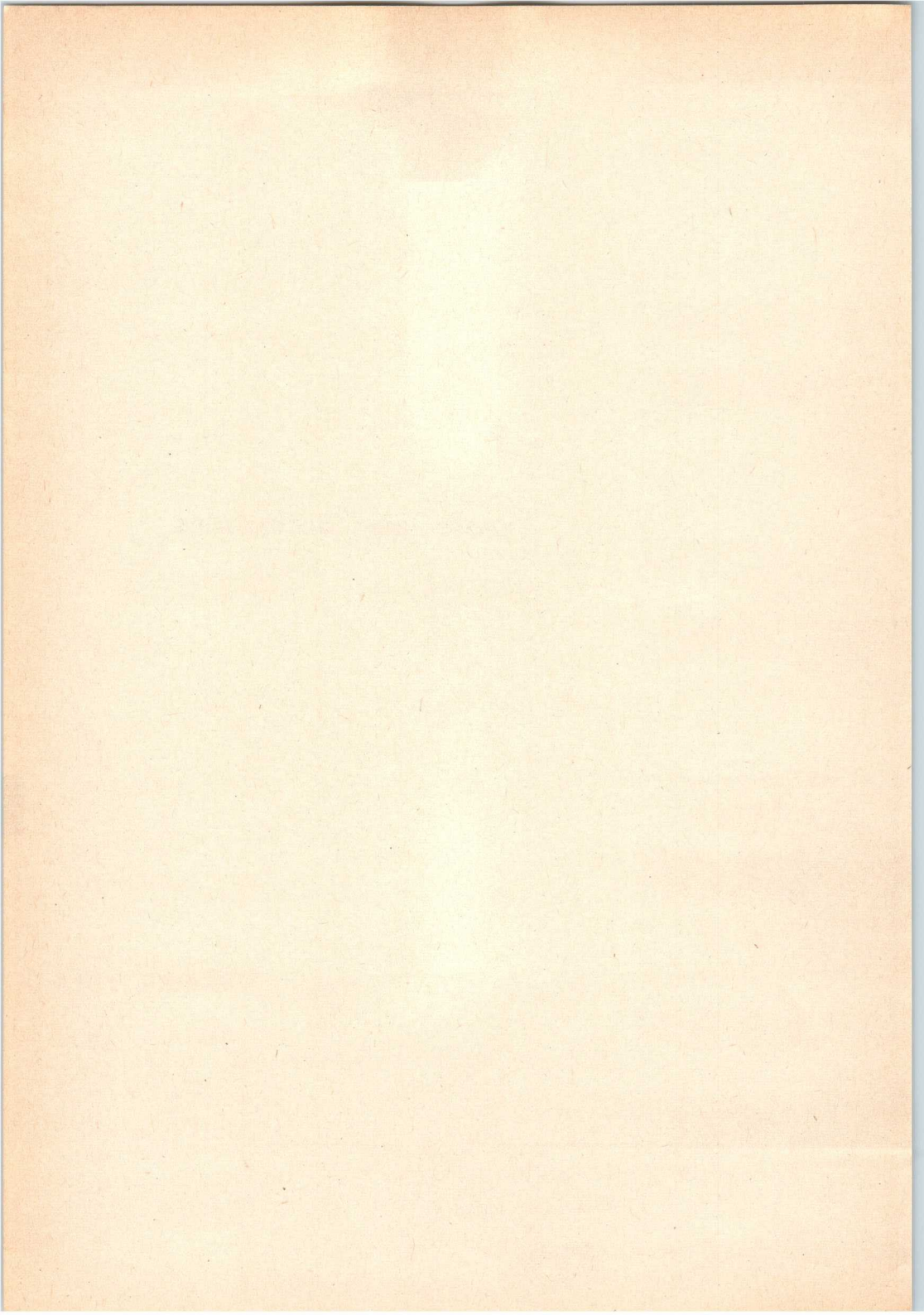

TUBE SOCKET

FOR 14-PIN ALL GLASS BASES

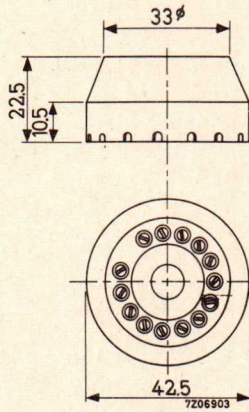

Material: Synthetic resin insulating material
14 silver plated fork-shaped contacts

MU-METAL SCREEN

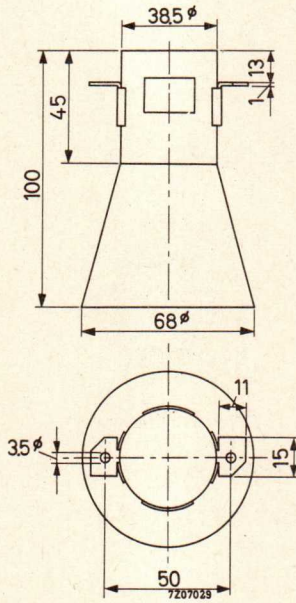

MU-METAL SCREEN

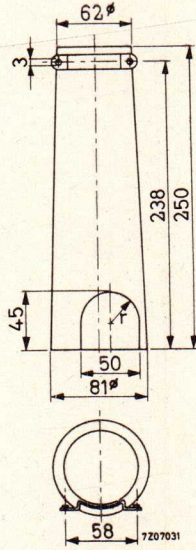

MU-METAL SCREEN

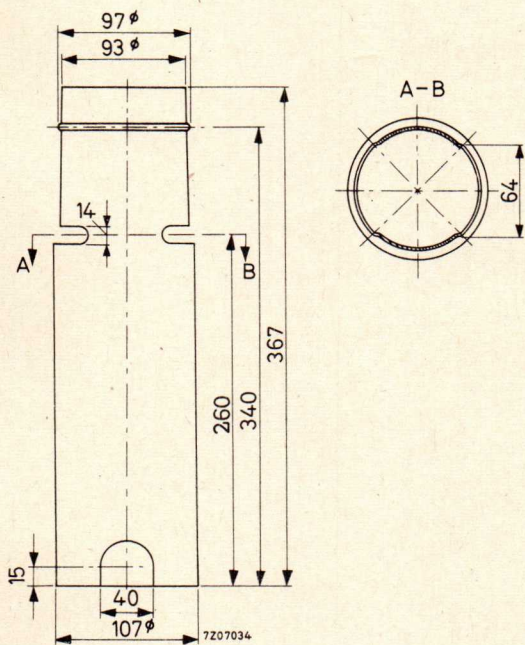

Material : Mu-metal

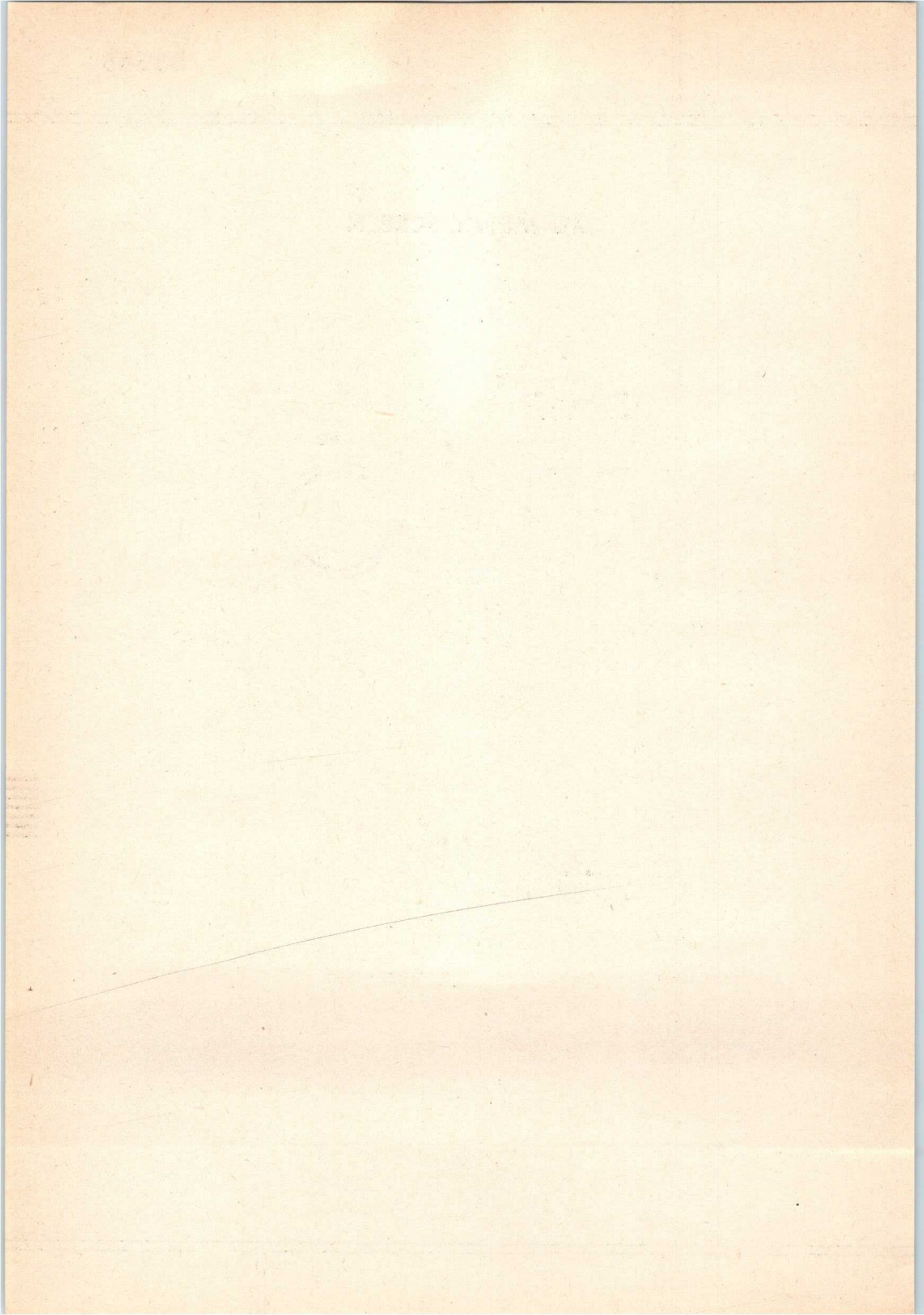

MU-METAL SCREEN

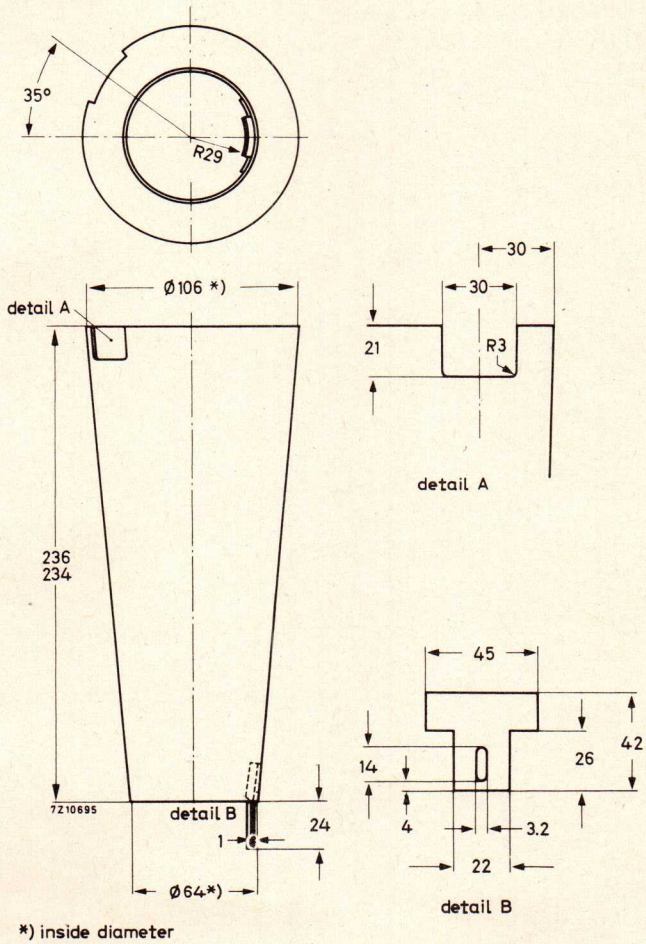

Material: Mu-metal, 0.35 mm thick

55548
55548A

MU-METAL SCREEN

Type 55548A without mounting bracket
Type 55548 with mounting bracket

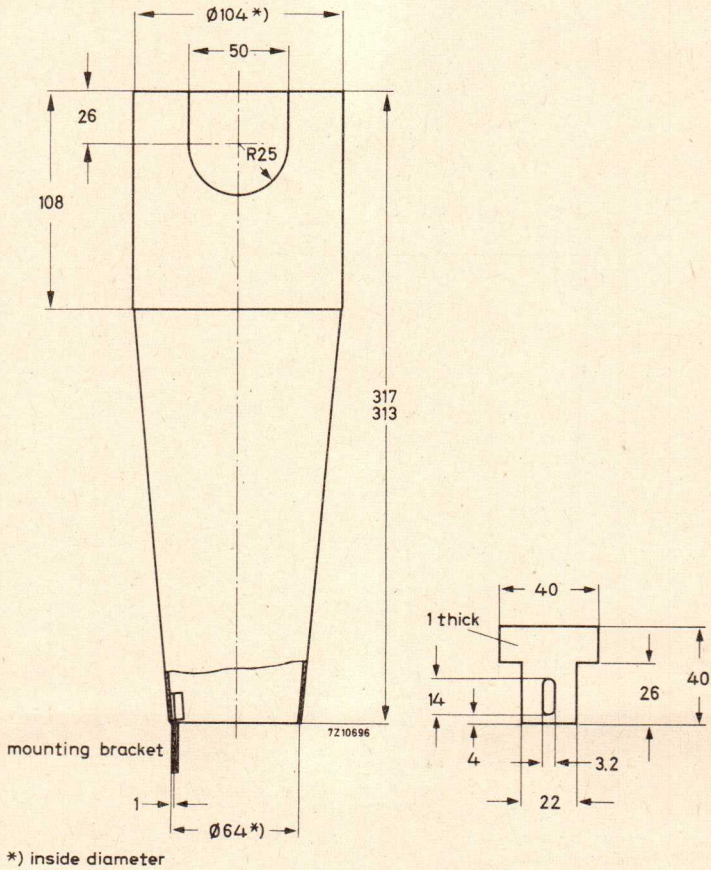

Material: Mu-metal, 0.5 mm thick

MU-METAL SCREEN

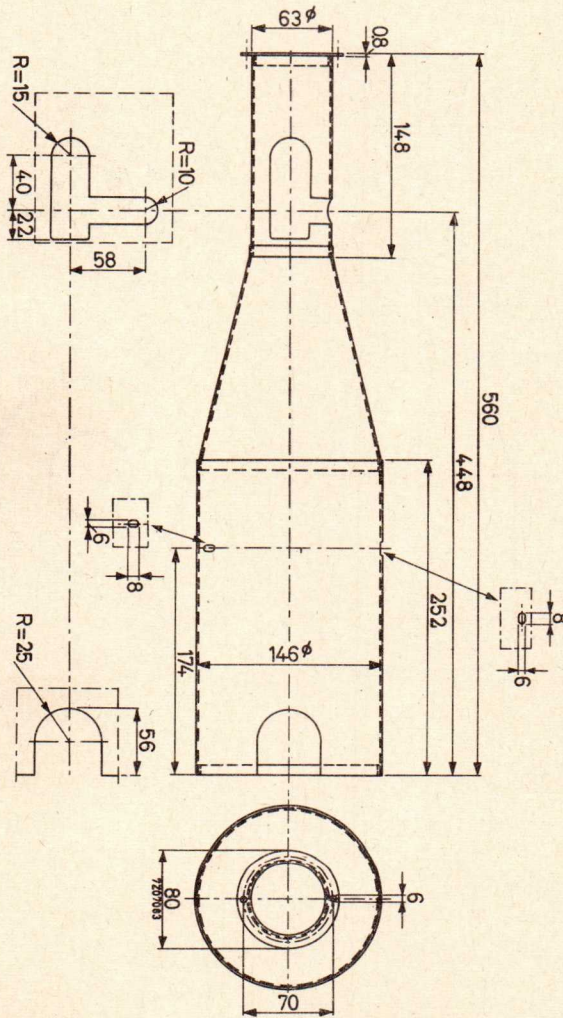

MU-METAL SCREEN

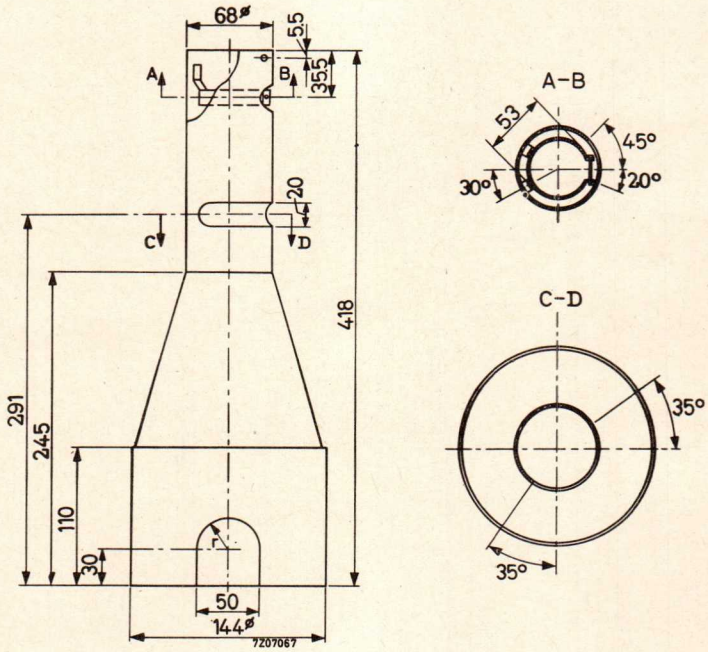

MU-METAL SCREEN

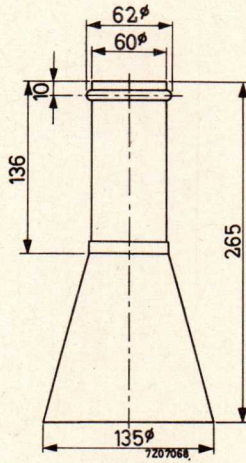

FINAL ACCELERATOR CONTACT CONNECTOR

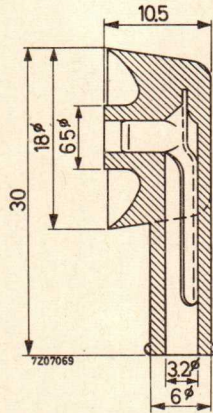

Material: cadmium plated spring contact
rubber insulating material

SIDE CONTACT CONNECTOR

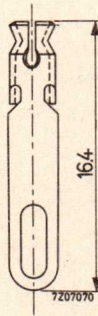

55563A

FINAL ACCELERATOR CONTACT CONNECTOR

Type 55563A supersedes type 55563.

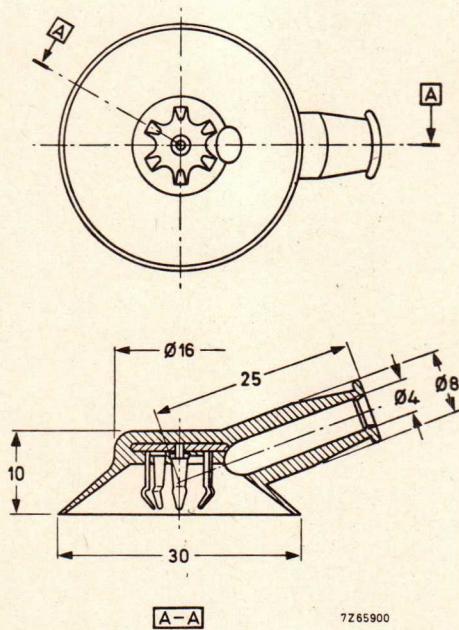

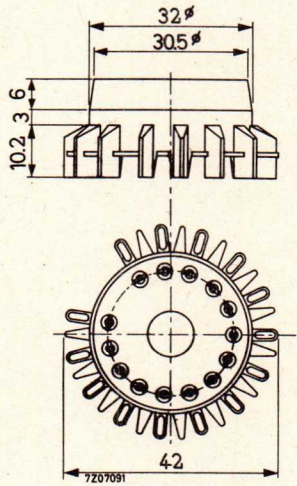
TUBE SOCKET FOR 14-PIN BASES

Material: synthetic resin insulating material
14 gold plated fork shaped contacts

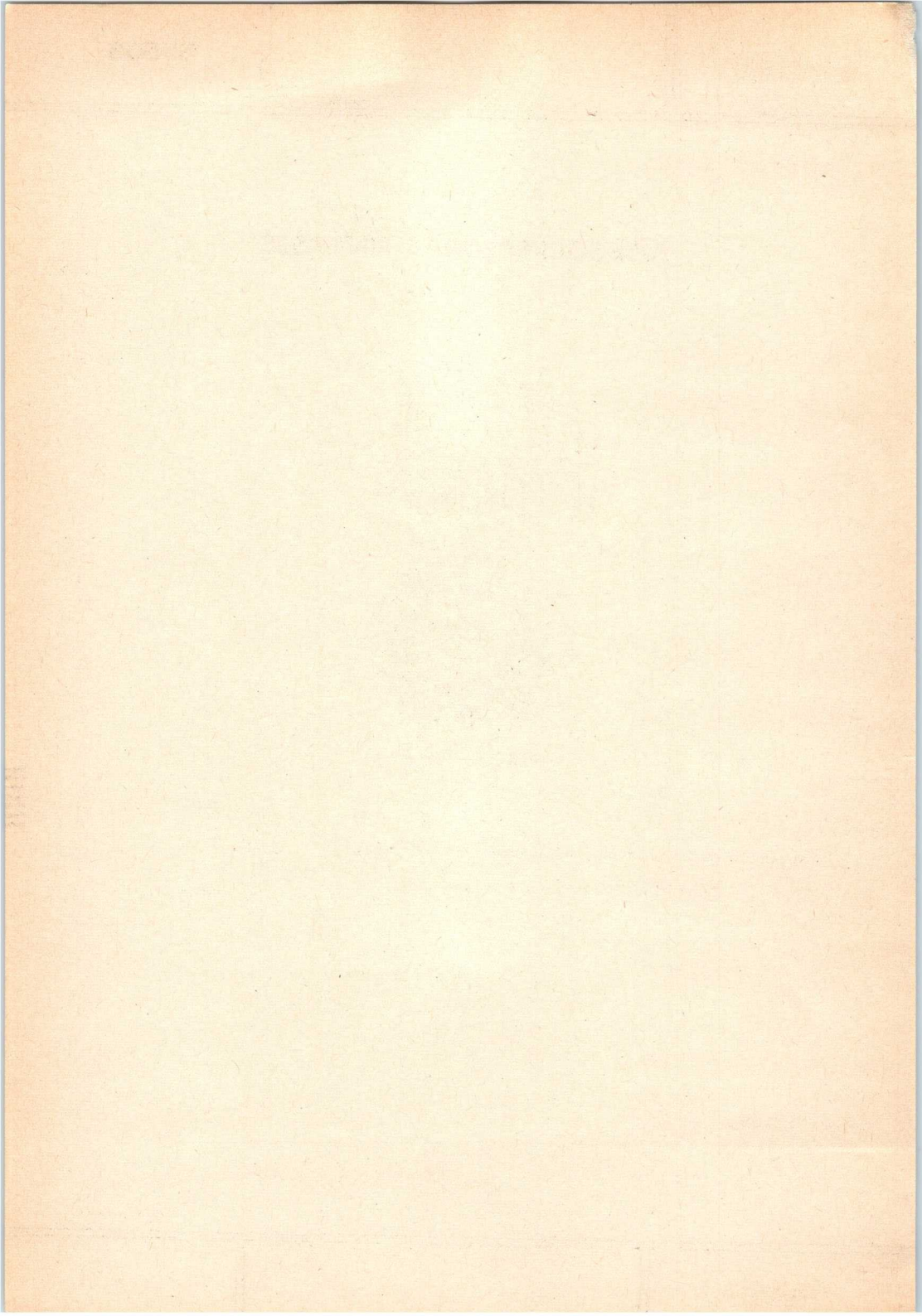

MU-METAL SCREEN

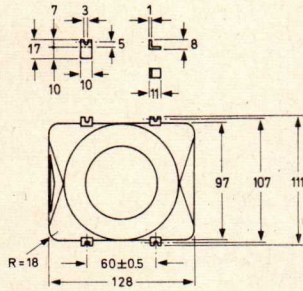

* Inside diameter

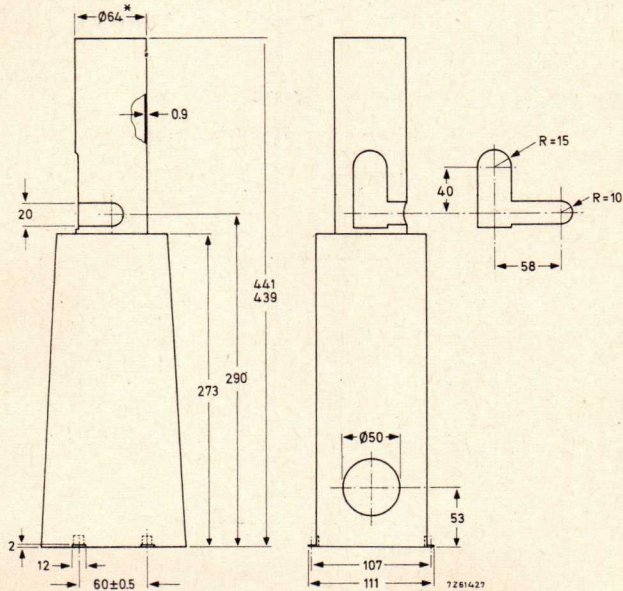

55580
55580A

MU-METAL SCREEN

Type 55580A with 4 mounting lugs L

Type 55580 without mounting lugs L

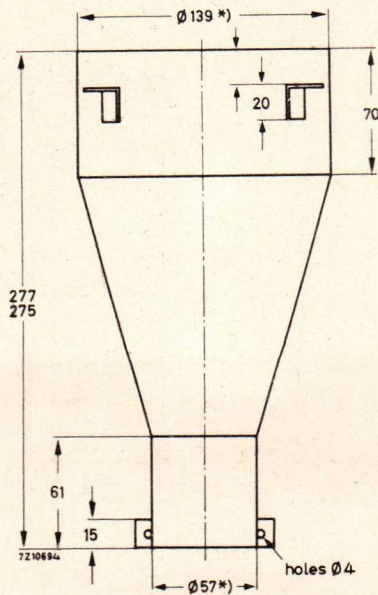
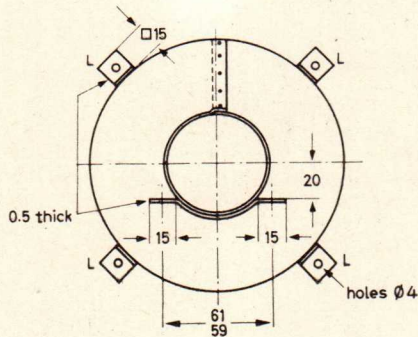

*) inside diameter

Material: Mu-metal, 0.35 mm thick

MU-METAL SCREEN

Type 55581A with hole H

Type 55581 without hole H

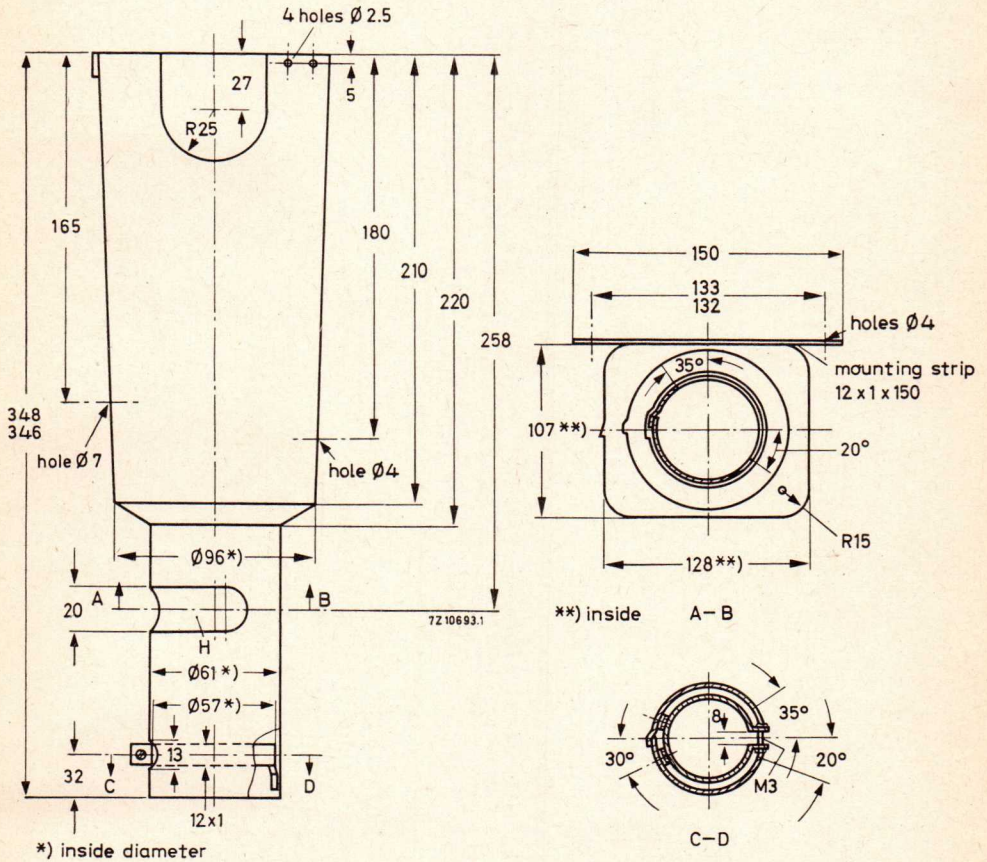

Material: Mu-metal, 0,5 mm thick.

MU-METAL SCREEN

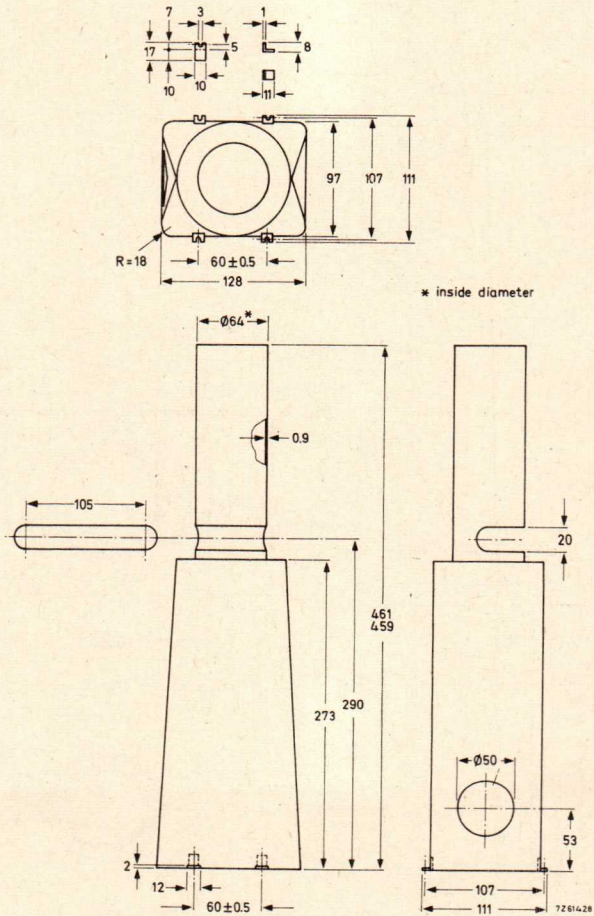

MU-METAL SCREEN

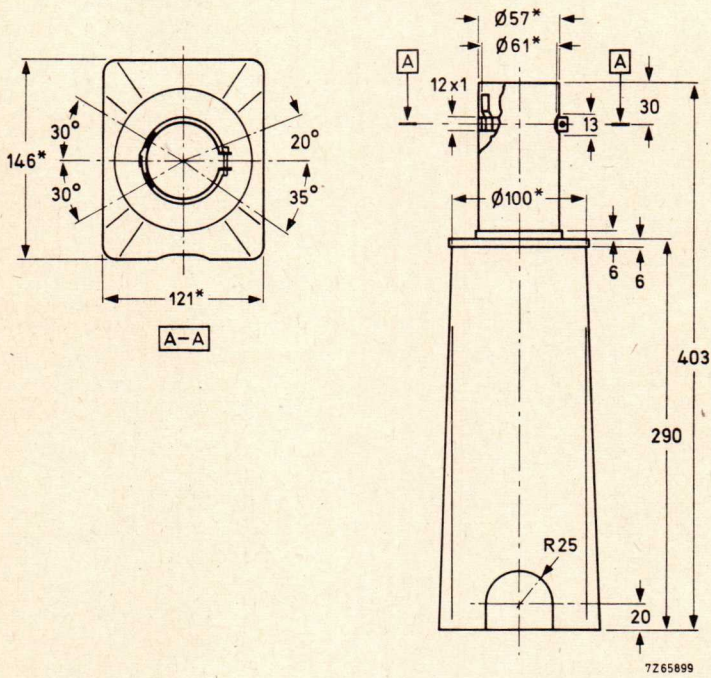

* Internal dimension

MU-METAL SCREEN

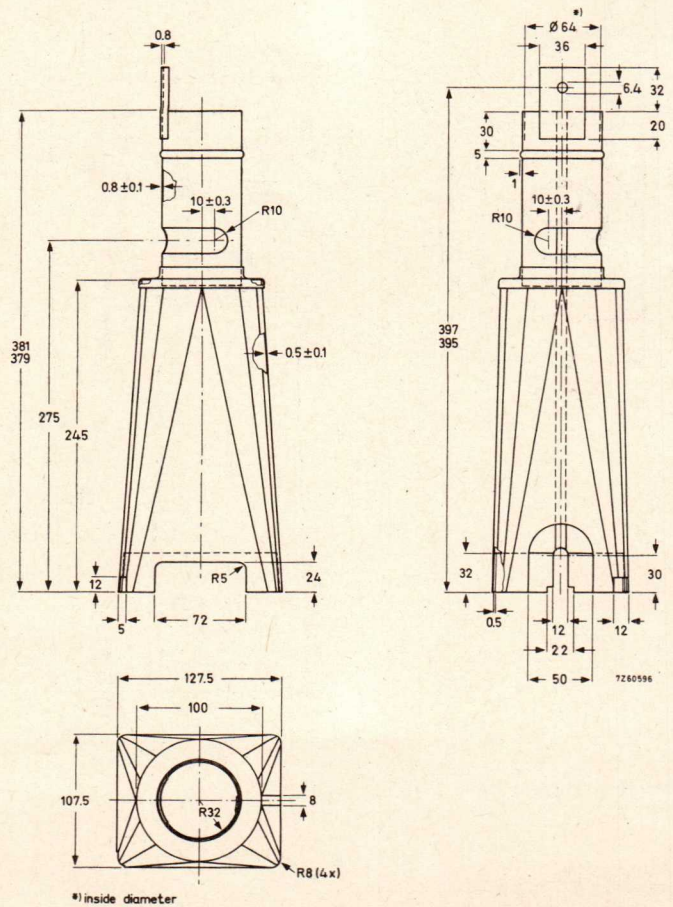

MU-METAL SCREEN

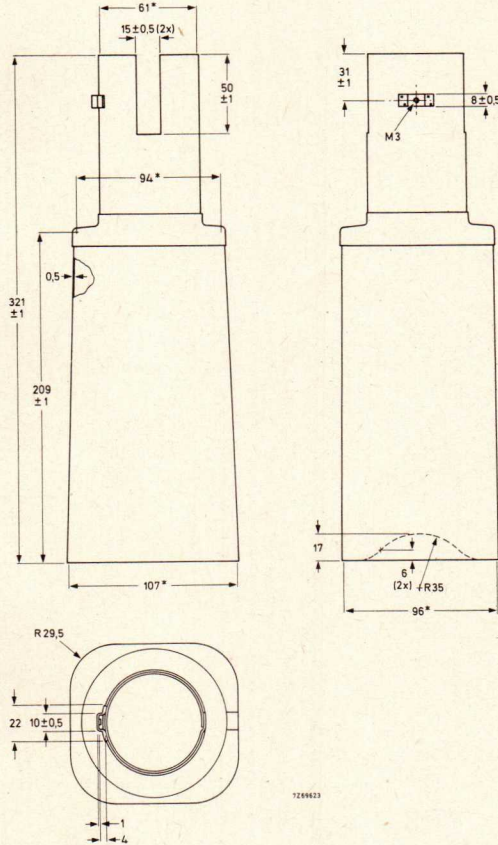

*Internal dimension

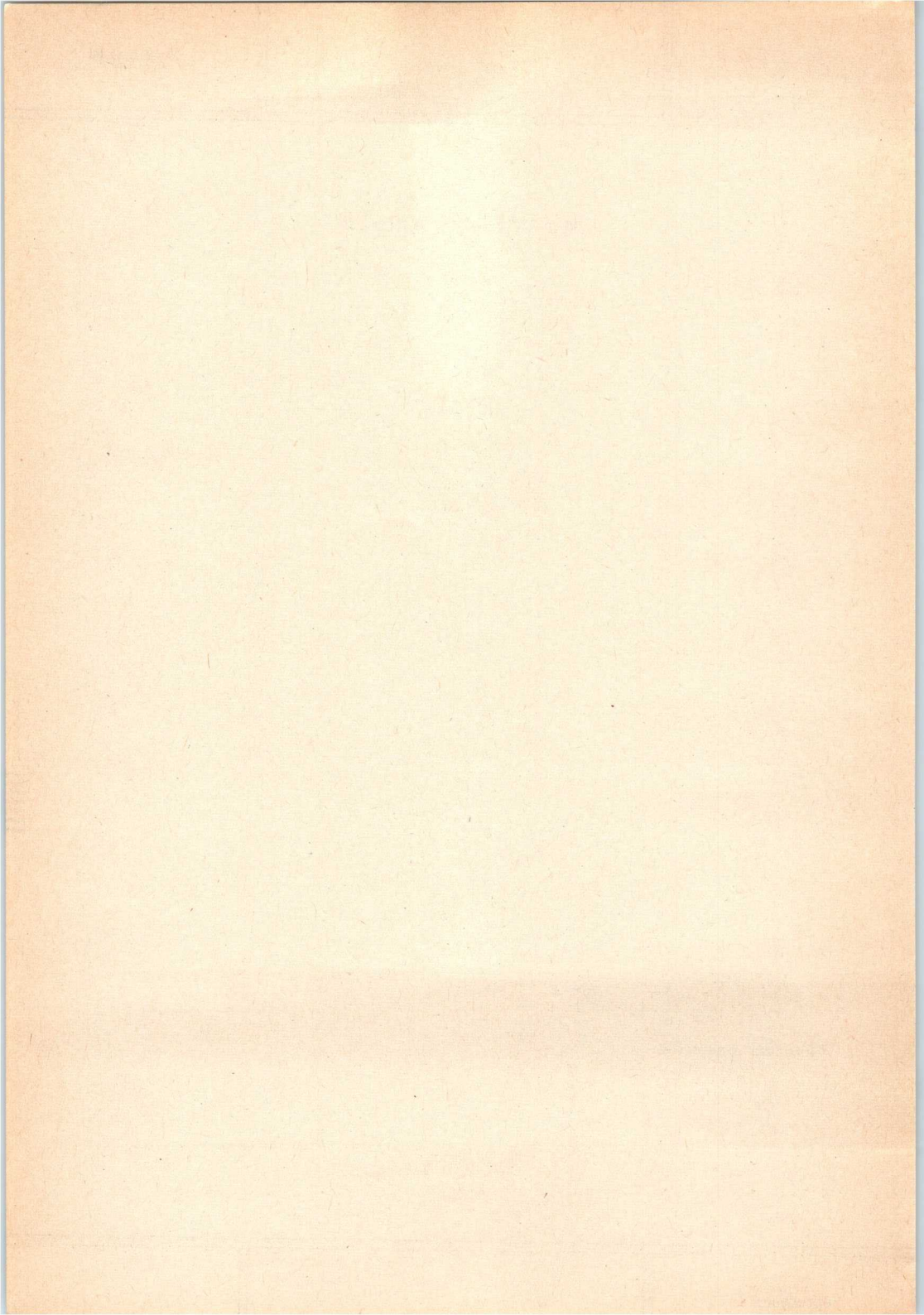

BEAM CENTRING MAGNET

INSTRUCTIONS FOR USE

To obtain the best performance from an electrostatically focussed tube, it is important that the axis of the beam should coincide with that of the lens. In practice this is not always so because of small errors in geometry. By means of this magnet it is possible to adjust, if necessary, the position of the beam and so produce a true alignment in every case. The effect is illustrated in Figs 1a and 1b which show enlarged views of a single element in a spot raster under the special operating conditions given in the directions for setting. With a well aligned beam, an image such as that in Fig. 1a can be seen. Very small errors will produce a spot as shown in Fig. 1b where the brightest part of the image does not appear in the centre of the diffused area or haze. In such a case, the picture quality would be good but with only a small adjustment of the beam, so that the brightest part becomes central, a noticeable improvement can be made.

The unit has a non-magnetic ring containing a diametrically magnetized Ferroxdure core and two soft-iron pole pieces covered with plastic material to protect the glass surface.

730723-23-02

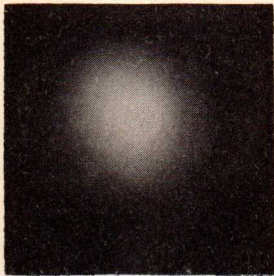

Fig. 1a

730723-23-01

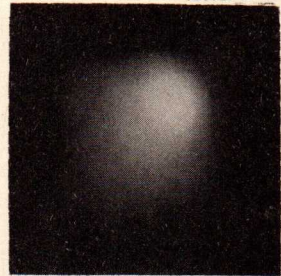

Fig. 1b

The field strength can be altered by turning the core as indicated in Fig. 2, and the direction by turning the whole unit. Moving the unit along the neck of the tube will cause a small change in the position of the beam but it is most effective at about 20 mm from the cap (Fig. 3).

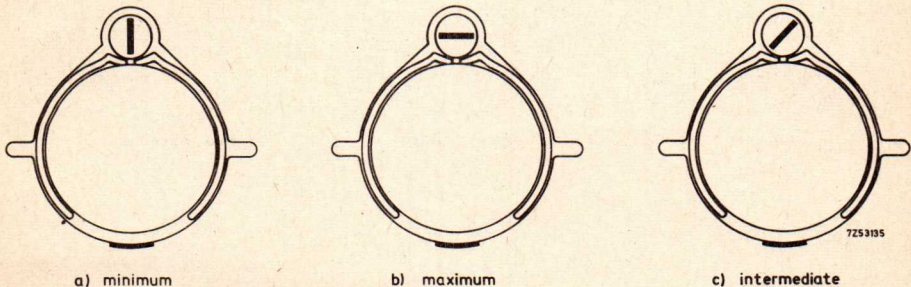

Fig. 2

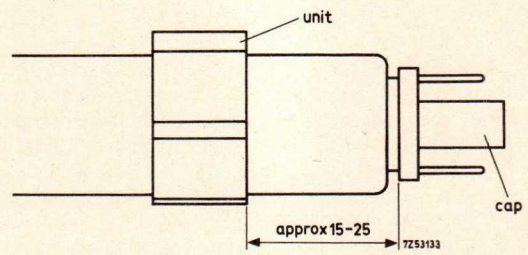

Fig. 3

SETTING

This can best be done with a spot raster on the screen, and by observing one of the elements near the centre. A suitable raster would have, for instance, a spot duration of $1/6 \mu s$ with a repetition time of $6 \mu s$ and an image as in Fig. 1 can then be produced with the following conditions.

V_f	=	6.3 V	}	or other conditions if required
$*V_{g1}$	=	0		
V_{g2}	=	600 V		
$V_{g3, g5(1)}$	=	16 kV		
V_{g4}	=	-300 to -500 V		

*) To avoid burning the screen, adjust slowly from -50 V to zero

Set the unit on the neck at about 20 mm from the cap and turn it until the brightest part of the image appears central in the haze.

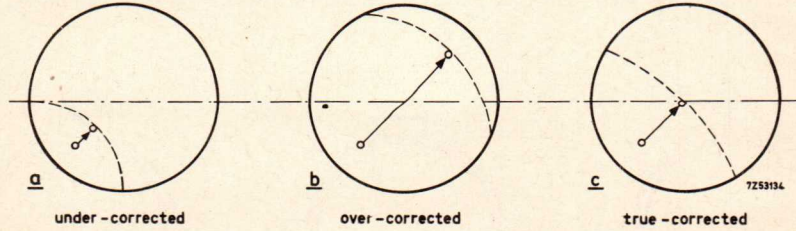

Fig. 4

The diagrams in Fig. 4 show the process of adjusting the brightest part from its original position to the centre. The distance between the two points will be determined by the field strength, and the position of the new point along the dotted line will depend on the direction of the field.

If the magnet is under or over-correcting as in (Figs 4a and 4b), the field strength must be changed. To do this, remove the unit from the neck, push the core out sufficiently to get a finger grip and turn it towards maximum or minimum Figs 2a and 2b as required. Return it to the stop in the clamp and set the unit once again on the neck.

If the means of producing a spot raster are not available, a test pattern or suitable picture can be used when setting. It is not easy with this method, however, to assess the degree of change needed in field strength or direction but if a start is made with the line on the core set at about 20° from the minimum position in Fig. 2, an improvement can be made in most cases where it is required. In others, it may be necessary to try one or two further core settings, but with a little experience it is not difficult to find an arrangement which gives the best vertical and horizontal resolution.

The unit should be sufficiently tight on the neck to prevent movement during transit but if, for some reason, this does not appear to be so, the bends on the ring should be compressed slightly.

Index

Maintenance type list

Obsolescent type list



INDEX OF TYPE NUMBERS

Type Number	Section	Type Number	Section	Type Number	Section
D7-190..	I. T.	D. 7-11	I. T.	55555	Acc.
D7-191..	I. T.	E10-12..	I. T.	55557	Acc.
D10-160..	I. T.	E10-130..	I. T.	55560	Acc.
D10-161..	I. T.	E14-100GH	I. T.	55561	Acc.
D10-170..	I. T.	E14-101GH	I. T.	55563A	Acc.
D13-16..	I. T.	L14-110GH/55	I. T.	55566	Acc.
D13-16.. /01	I. T.	L14-130GH/55	I. T.	55568	Acc.
D13-26..	I. T.	M17-140W	M	55580	Acc.
D13-26.. /01	I. T.	M17-141W	M	55580A	Acc.
D13-27..	I. T.	M21-11W	M	55581	Acc.
D13-451.. /45	I. T.	M21-12W	M	55581A	Acc.
D13-480..	I. T.	M24-100W	M	55582	Acc.
D13-481..	I. T.	M24-101W	M	55584	Acc.
D13-500GH/01	I. T.	M31-130W	M	55585	Acc.
D14-120GH	I. T.	M31-131W	M	55587	Acc.
D14-121GH	I. T.	M38-120W	M	3322 142 11401	Acc.
D14-122GH	I. T.	M38-121W	M		
D14-123GH	I. T.	MG/U/Y13-38	S. C. T.		
D14-160GH/09	I. T.	MW13-38	S. C. T.		
D14-162GH/09	I. T.	Q7-100GU	S. C. T.		
D14-240GH/09	I. T.	Q13-110	S. C. T.		
D14-240GH/37	I. T.	40467	Acc.		
D14-250GH	I. T.	55530	Acc.		
D14-251GH	I. T.	55532	Acc.		
D18-120..	I. T.	55534	Acc.		
DG7-5	I. T.	55545	Acc.		
DG7-6	I. T.	55547	Acc.		
DG7-31	I. T.	55548	Acc.		
DG7-32	I. T.	55548/A	Acc.		
DH3-91	I. T.	5554	Acc.		

Acc. = Accessories

I. T. = Instrument tubes

M = Monitor and display tubes

S. C. T. = C-R tubes for special applications

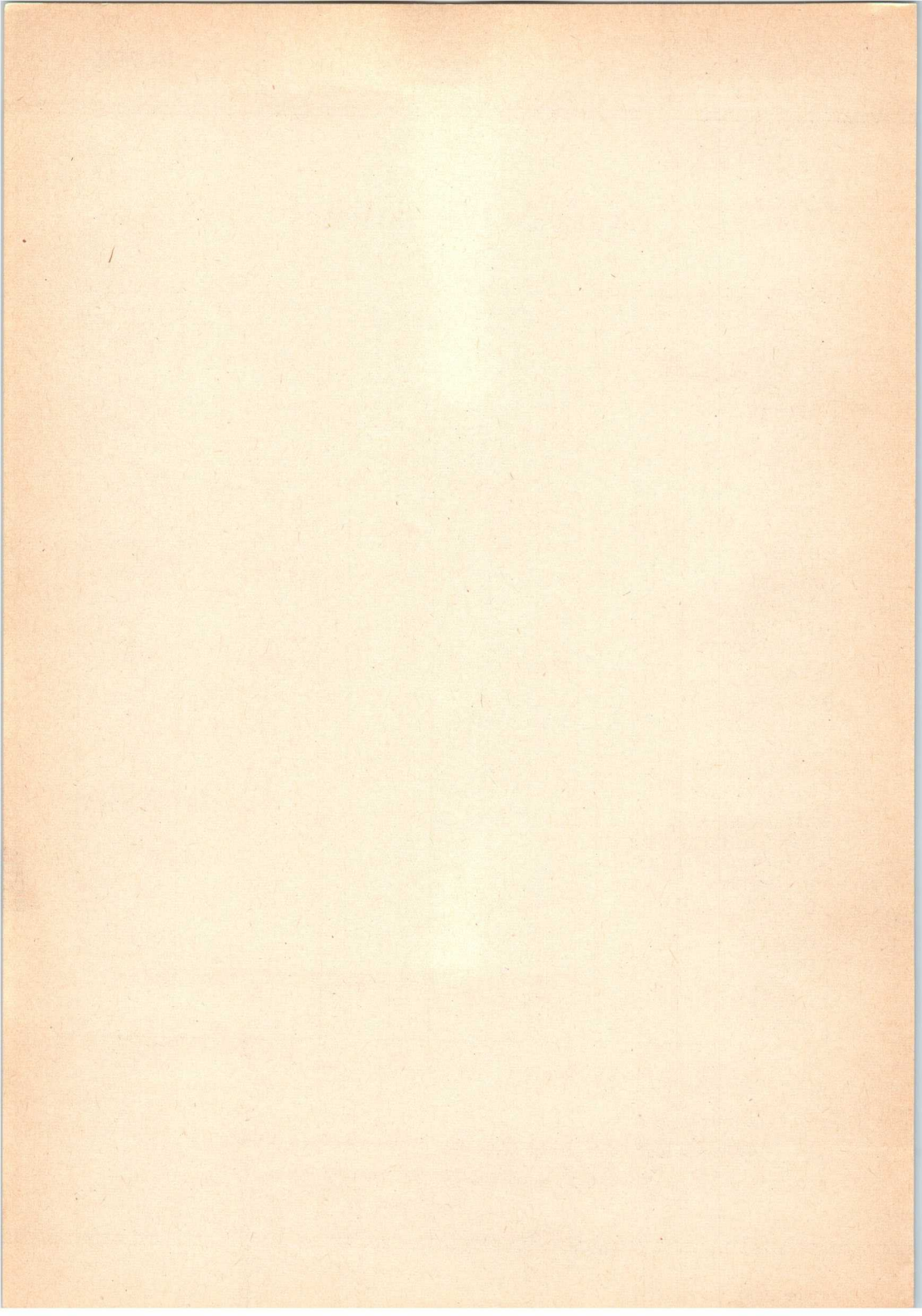

MAINTENANCE TYPE LIST

Maintenance types are available for equipment maintenance. No longer recommended for equipment production.

Abridged data are included in this Handbook.

D10-170..

E 10-12..

D18-120..

E 10-130..

DG7-5

DG7-6

OBSOLESCE TYPE LIST

Obsolescent types are available until present stocks are exhausted.

Abridged data are included in this Handbook.

D13-16..

M21-11 W

D13-16../01

M21-12 W

D13-26..

D13-26../01

D13-451../45

D14-160GH/09.

CATHODE-RAY TUBES

General and screen types

Instrument tubes

Monitor and display tubes

C-R tubes for special applications

Associated accessories

Index, Maintenance type list, Obsolescent type list

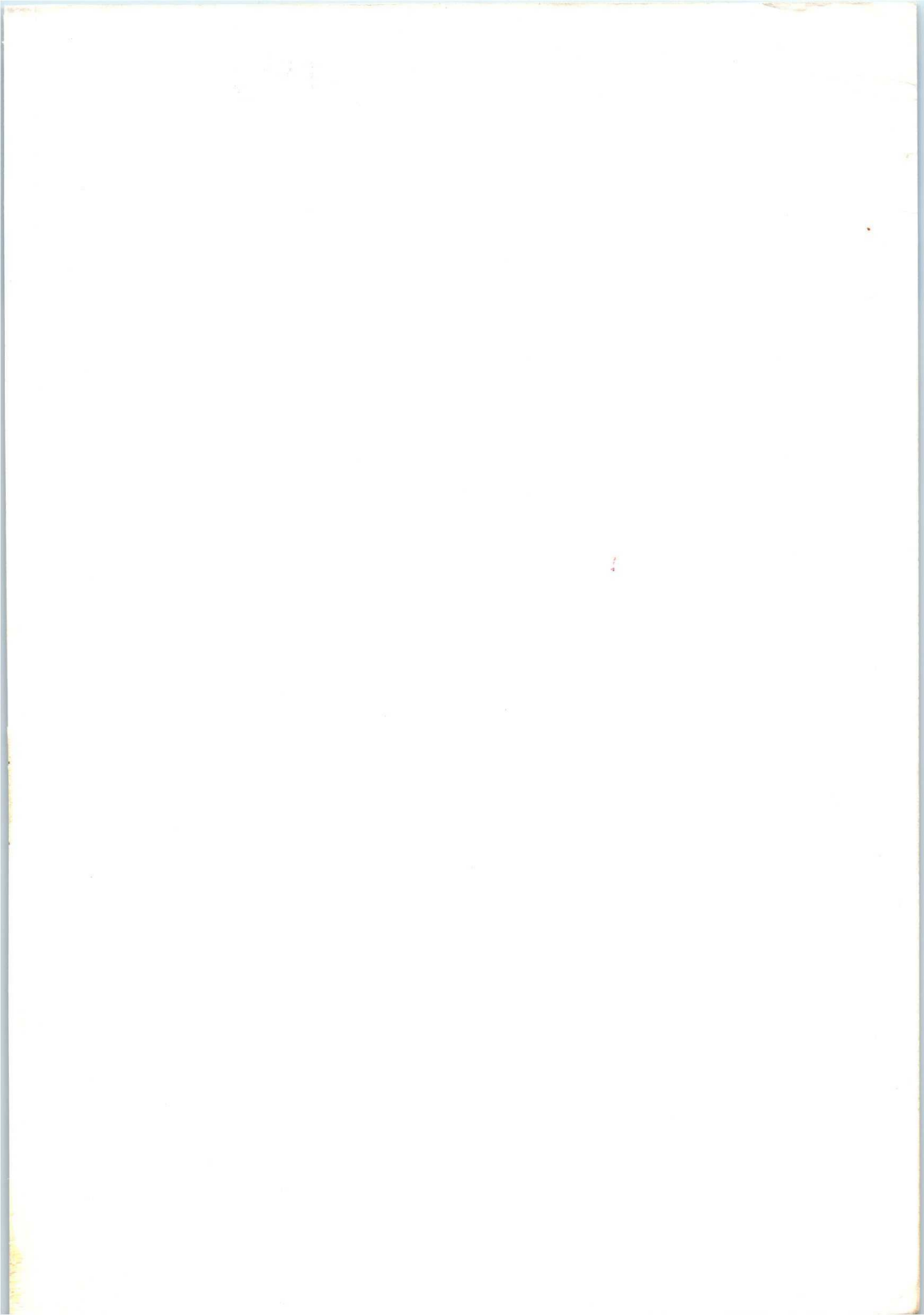

Electronic components and materials for professional, industrial and consumer uses from the world-wide Philips Group of Companies

- Argentina:** FAPESA I.y.C., Av. Crovara 2550, Tablada, Prov. de BUENOS AIRES, Tel. 652-7438/7478.
- Australia:** PHILIPS INDUSTRIES HOLDINGS LTD., Elcoma Division, 67 Mars Road, LANE COVE, 2066, N.S.W., Tel. 42 1261.
- Austria:** ÖSTERREICHISCHE PHILIPS BAUELEMENTE Industrie G.m.b.H., Zieglergasse 6, A-1072 WIEN, Tel. 93 26 22.
- Belgium:** M.B.L.E., 80, rue des Deux Gares, B-1070 BRUXELLES, Tel 523 00 00.
- Brazil:** IBRAPE S.A., Caixa Postal 7383, Av. Paulista 2073-S/Loja, SAO PAULO, ☎P, Tel. 287-7144, 01311.
- Canada:** PHILIPS ELECTRONICS INDUSTRIES LTD., Electron Devices Div., 116 Vanderhoof Ave., TORONTO 17, Ontario, Tel. 425-5161.
- Chile:** PHILIPS CHILENA S.A., Av. Santa Maria 0760, SANTIAGO, Tel. 39-40 01.
- Colombia:** SADAPE S.A., P.O. Box 9805 Calle 13, No. 51 + 39, BOGOTA D.E. 1., Tel. 600 600.
- Denmark:** MINIWATT A/S, Emdrupvej 115A, DK-2400 KØBENHAVN NV., Tel. (01) 69 16 22.
- Finland:** OY PHILIPS AB, Elcoma Division, Kaivokatu 8, SF-00100 HELSINKI 10, Tel. 1 72 71.
- France:** R.T.C. LA RADIOTECHNIQUE-COMPELEC, 130 Avenue Ledru Rollin, F-75540 PARIS 11, Tel. 355-44-99.
- Germany:** VALVO, UB Bauelemente der Philips G.m.b.H., Valvo Haus, Burchardstrasse 19, D-2 HAMBURG 1, Tel. (040) 3296-1.
- Greece:** PHILIPS S.A. HELLENIQUE, Elcoma Division, 52, Av. Syngrou, ATHENS, Tel. 915 311.
- Hong Kong:** PHILIPS HONG KONG LTD., Components Dept., 11th Fl., Din Wai Ind. Bldg., 49 Hoi Yuen Rd, KWUNTONG, Tel. K-42 72 32.
- India:** PHILIPS INDIA LTD., Elcoma Div., Band Box House, 254-D, Dr. Annie Besant Rd., Prabhadevi, BOMBAY-25-DD, Tel. 457 311-5.
- Indonesia:** P.T. PHILIPS-RALIN ELECTRONICS, Elcoma Division, 'Timah' Building, Jl. Jen. Gatot Subroto, JAKARTA, Tel. 44 163.
- Ireland:** PHILIPS ELECTRICAL (IRELAND) LTD., Newstead, Clonskeagh, DUBLIN 14, Tel. 69 33 55.
- Italy:** PHILIPS S.P.A., Sezione Elcoma, Piazza IV Novembre 3, I-20124 MILANO, Tel. 2-6994.
- Japan:** NIHON PHILIPS CORP., 32nd Fl., World Trade Center Bldg., 5, 3-chome, Shiba Hamamatsu-cho, Minato-ku, TOKYO, Tel. 03-435-5268.
- Korea:** PHILIPS ELECTRONICS (KOREA) LTD., Philips House, 260-199 Itaewon-dong, Yongsan-ku, C.P.O. Box 3680, SEOUL, Tel. 44-4202.
- Mexico:** ELECTRONICA S.A. de C.V., Varsovia No. 36, MEXICO 6, D.F., Tel. 5-33-11-80.
- Netherlands:** PHILIPS NEDERLAND B.V., Afd. Elonco, Boschdijk 525, NL-4510 EINDHOVEN, Tel. (040) 79 33 33.
- New Zealand:** EDAC LTD., 70-72 Kingsford Smith Street, WELLINGTON, Tel. 873 1559.
- Norway:** ELECTRONICA A/S., Vitaminveien 11, P.O. Box 29, Grefsen, OSLO 4, Tel. (02) 15 05 90.
- Peru:** CADESA, Jr. Ilo, No. 216, Apartado 10132, LIMA, Tel. 27 73 17.
- Philippines:** ELDAC, Philips Industrial Dev. Inc., 2246 Pasong Tamo, MAKATI-RIZAL, Tel. 86-89-51 to 59.
- Portugal:** PHILIPS PORTUGUESA S.A.R.L., Av. Eng. Duharte Pacheco 6, LISBOA 1, Tel. 68 31 21.
- Singapore:** PHILIPS SINGAPORE PTE LTD., Elcoma Div., POB 340, Toa Payoh CPO, Lorong 1, Toa Payoh, SINGAPORE 12, Tel. 53 88 11.
- South Africa:** EDAC (Pty.) Ltd., South Park Lane, New Doornfontein, JOHANNESBURG, Tel. 24/6701-2.
- Spain:** COPRESA S.A., Balmes 22, BARCELONA 7, Tel. 301 63 12.
- Sweden:** A.B. ELCOMA, Lidövägen 50, S-10 250 STOCKHOLM 27, Tel. 08/67 97 80.
- Switzerland:** PHILIPS A.G., Elcoma Dept., Edenstrasse 20, CH-8027 ZÜRICH, Tel. 01/44 22 11.
- Taiwan:** PHILIPS TAIWAN LTD., 3rd Fl., San Min Building, 57-1, Chung Shan N. Rd, Section 2, P.O. Box 22978, TAIPEI, Tel. 5513101-5.
- Turkey:** TÜRK PHILIPS TICARET A.S., EMET Department, Gümüssuyu Cad. 78-80, Beyoğlu, ISTANBUL, Tel. 45 32 50.
- United Kingdom:** MULLARD LTD., Mullard House, Torrington Place, LONDON WC1E 7HD, Tel. 01-580 6633.
- United States:** NORTH AMERICAN PHILIPS ELECTRONIC COMPONENT CORP., 230, Duffy Avenue, HICKSVILLE, N.Y. 11802, Tel. (516) 931-6200.
IC Products: SIGNETICS CORPORATION, 811 East Arques Avenue, SUNNYVALE, California 94086, Tel. (408) 739-7700.
- Uruguay:** LUZILECTRON S.A., República 1567, piso 5, MONTEVIDEO, Tel. 9 43 21.
- Venezuela:** IND. VENEZOLANAS PHILIPS S.A., Elcoma Dept., A. Ppal de los Ruices, Edif. Centro Colgate, Apdo 1167, CARACAS, Tel. 36 05 11.