

RCA

# Traveling-Wave Tubes and Subsystems



## RCA Traveling-Wave Tubes and Subsystems

- **High Gain, Broadband Microwave Amplifiers**
- **Lightweight, Rugged Construction**
- **Proven Reliable Performance**
- **Integral Power Supplies Available With Most TWT's**

From laboratory to commercial device, RCA has paced the progress of traveling-wave tube development. Since 1956, when the first commercial low-noise tube was announced, RCA TWT's have participated in every major ECM system. Adept in the application of PPM traveling-wave tubes operating over full octave bandwidths, RCA has introduced:

- First practical PPM traveling-wave tubes for airborne applications.
- First ruggedized PPM traveling-wave tube for military airborne systems.
- PPM traveling-wave tubes with temperature compensation.
- First PPM traveling-wave tubes for commercial service.
- First miniaturized (<1" dia.) PPM traveling-wave tube.
- First PPM traveling-wave tubes operating in a memory storage loop over a full octave frequency.
- First reliable, long-life PPM traveling-wave tube in an orbiting communications satellite.
- First use of a high-sensitivity photocathode with a Helix structure in a traveling-wave tube.

Information furnished by RCA is believed to be accurate and reliable. However, no responsibility is assumed by RCA for its use; nor for any infringements of patents or other rights of third parties which may result from its use. No license is granted by implication or otherwise under any patent or patent rights of RCA.



RCA TWT capability should be considered in the following areas:

- Communications ..... Page 4
- Electronic Countermeasures ..... Page 6
- Manufacturing Capability and Facilities .... Page 12

Profile of RCA TWT Types  
Frequency-Power Spectrum

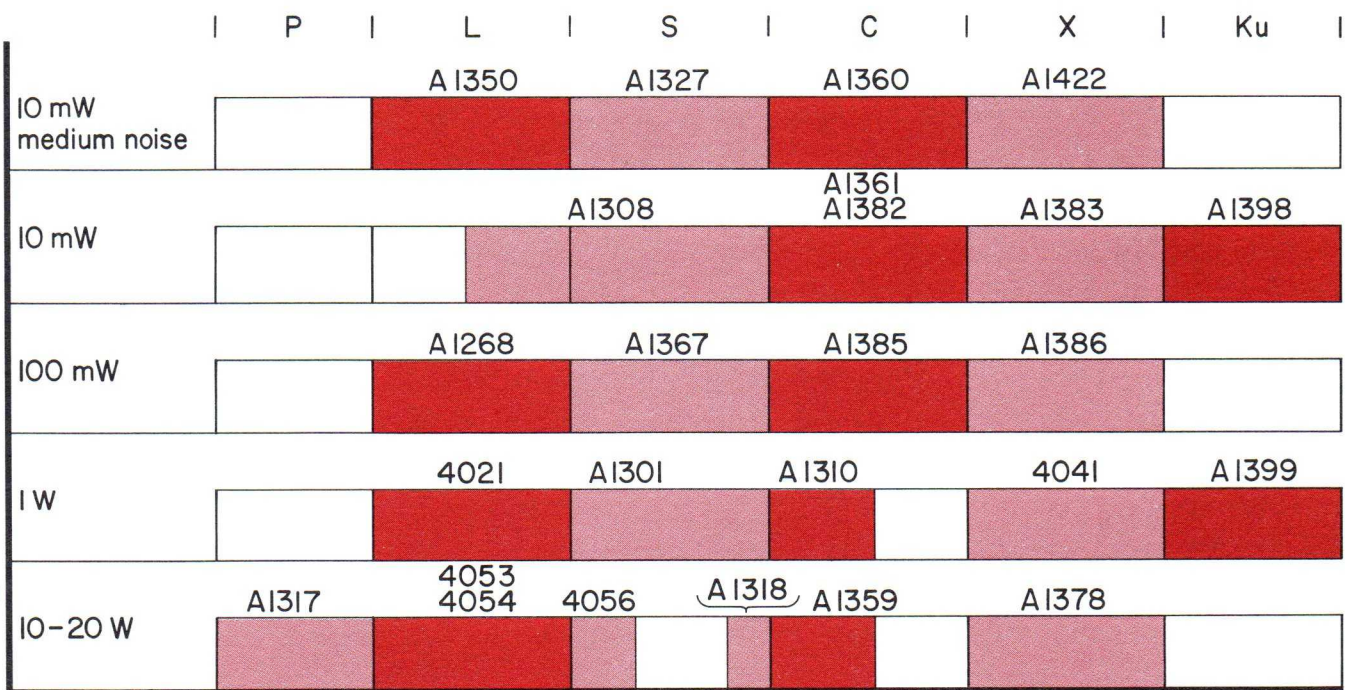

## Communication Traveling-Wave Tubes

Communication traveling-wave tubes are used as amplifiers in the links of many single- or multiple-link microwave radio relay systems. The systems may be ground-based or based in space-orbiting satellites. Communication traveling-wave tubes designed specifically for ground-based applications have certain basic differences as compared to tubes designed for satellite applications. Ground-based systems are multi-link systems spanning states, countries, or even continents (satellite systems are usually only single-link systems). Hence to reduce the cumulative distortion due to the non-linearities of all the tubes in the chain, the electrical performance requirements of ground-based systems are usually more stringent. In addition, the larger number of tubes required make low cost, ease of adjustment, and ease of replacement important considerations. Long life and good reliability are of importance for both types of systems, but they are much more important for satellite systems.

The main purpose of both types of communications systems is to transmit intelligence with a minimum of distortion. The manner in which this requirement affects the design of the tube will depend on the type of modulation used; but it will be found that the following tube characteristics will generally be of utmost importance:

- Linearity of gain response at the tube operating point (AM to PM conversion).

- Gain flatness over the signal channel.

- Intermodulation distortion.

- Absence of spurious noise signals (harmonics).

**AM to PM Conversion.** The AM/PM conversion is defined as the change of phase angle in degrees between the input signal and output signal per decibel variation in input power for a given value of output power. This factor is normally measured dynamically and the result expressed in

degrees per decibel at a specified value of power output. The tube operating point is very important since the AM/PM conversion varies greatly with respect to the power output of the tube. As a general rule, the input power level begins to effect phase at a level about 20 dB below the input required for saturation of the tube. The AM/PM conversion increases rapidly above this power input level until a level about 10 dB above saturation is reached. Beyond this point the phase angle reverses and becomes unpredictable. Thus, to maintain a low value of AM/PM conversion, the tube must be operated at a point well below its maximum power capability. **Figure 1** shows the AM/PM conversion characteristics of a typical RCA communications tube. This figure shows power output and phase variations as a function of input power for the RCA-4054.

**Gain Flatness and Fine-Grain Gain.** The usual octave-bandwidth traveling-wave tube will have an average gain variation of 4-6 dB over its operating bandwidth. This can be reduced to 2-3 dB by special gain-shaping techniques within and external to the tube. Of more importance to communication systems is the incremental fine-grain gain variation over small bandwidth intervals. A typical specification requirement for fine-grain gain is a maximum slope of 0.02 dB/MHz over any 15 MHz interval. To meet this incremental requirement the fine-grain gain usually varies no more than 0.25 to 0.5 dB from the average gain curve.

Variations in the fine-grain gain of a traveling-wave tube are caused primarily by internal reflections in the tube. Reflections are amplified in the tube and create variations in the output signal. The primary signal that is amplified can be either enhanced or degraded by the reflected signal, depending upon the phase relationship of this reflected signal. The principal sources of the internal reflections are variations in the pitch of the tube helix and the ends of the attenuator.

RCA maintains fine-grain gain variations to a low level by the use of helices wound on a precision helix winder developed by the RCA Equipment Development group. Inspection of helices with an automatic optical measurement tool insures that only helices with an acceptable low turn-to-turn pitch deviation are used in tubes. The pitch deviation of helices used in communication tubes is normally limited to a maximum of approximately  $\pm 1\%$ . Reflections from the ends of the attenuator are maintained at an extremely low level in RCA tubes by carefully tapering the resistive loss at the ends of the attenuator. **Figure 2** is a plot of fine-grain gain of the RCA-A1310 traveling-wave tube.

**Intermodulation Distortion.** The non-linearity of traveling-wave tube gain characteristics can result in the generation of spurious signals. The process in which traveling-wave tubes produce spurious signals from two or more input frequencies is designated intermodulation. These new frequencies or intermodulation products represent a distortion in the frequency spectrum and their amplitudes depend on the level of the input signals relative to the saturation level of the tube. To minimize intermodulation distortion, communication tubes are normally operated substantially below their saturation power level.

**Harmonics.** Due to the non-linearity of traveling-wave tubes near or beyond saturation, distortion occurs when tubes are driven to saturation. This produces harmonics of the fundamental input frequency at the output. The ratio of harmonic power to fundamental power is dependent upon the design of the tube and upon the operating point used. In the small-signal or linear operating region of the tube, harmonic content is almost non-existent. When a tube is operated in its non-linear region near saturation, the harmonic content is much greater. The harmonic power may actually exceed the fundamental power at operating points beyond saturation unless



a tube is specifically designed for low harmonic power output. Where harmonic power is undesirable, the tube must generally be operated more than 3 dB below its saturation power output point. Also, since helix voltage affects the harmonic power output of a traveling-wave tube, the helix voltage should be adjusted for minimum harmonic output at the opera-

ting point of the tube. RCA has greatly reduced the harmonic power output of traveling-wave tubes by utilizing helices with a specially-tapered pitch in the output section of the slow-wave circuit.

**Power Supplies.** RCA can provide integral or separate solid-state power supplies for most of the RCA communications trav-

eling-wave tubes. Often this better control of the interface between the power supply and the traveling-wave tube results in improved tube performance for AM to PM conversion, phase sensitivity, and other voltage-related characteristics. Furthermore, trade-offs can usually be made in the specifications to provide maximum performance at minimum cost.

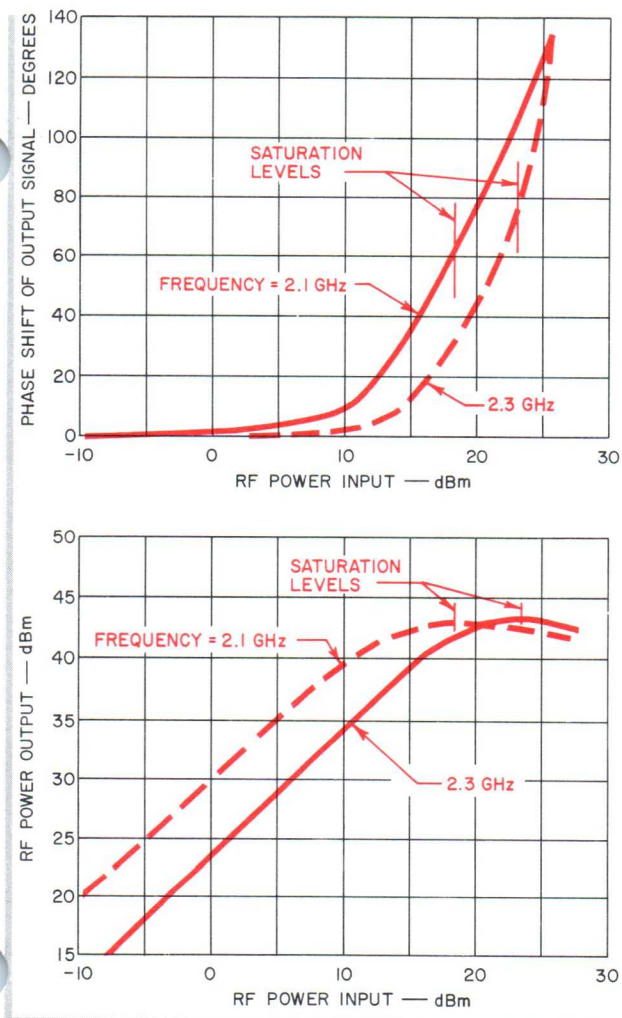

Figure 1 — AM/PM Conversion as a Function of Power Input for the RCA-4054 Medium-Power Traveling-Wave Tube.

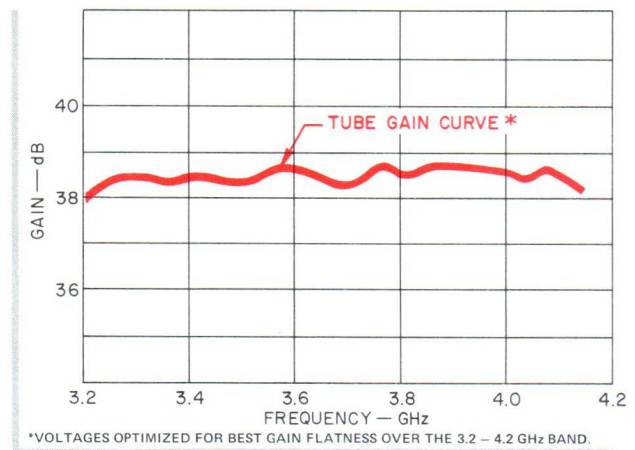

Figure 2 — Small Signal Gain as a Function of Frequency for the RCA-A1310

| Type No. | Frequency Range GHz | Power Output W |
|----------|---------------------|----------------|
| A1317    | .75 - 1.0           | 20             |
| 4053     | 1.0 - 2.0           | 10             |
| 7642     | 1.7 - 2.3           | 18             |
| 4054     | 1.7 - 2.7           | 20             |
| A1359    | 4.4 - 5.0           | 15             |
| A1310V1  | 4.4 - 5.0           | 3              |
| A1358    | 5.8 - 6.4           | 3              |
| A1378    | 7.9 - 8.4           | 20             |

Any of the above tubes can be customized to operate in adjacent frequency bands.

Table 1 — Characteristics of Typical RCA Communications Traveling-Wave Tubes

# The Role of Traveling-Wave Tubes in Electronic Countermeasure Systems

The traveling-wave tube is uniquely suited to use as a wideband microwave amplifier. Its inherent ability to provide the highest gain-bandwidth product of any amplifying device over octave bandwidths at microwave frequencies makes it a key component for "active" electronic countermeasure systems. For optimum effectiveness, ECM systems must respond to a wide band of unfriendly radar signals over extremes in operating environment (shipboard or airborne); and in turn retransmit deceptive or erroneous range information. Moreover, the systems must operate effectively over wide ranges of frequencies, signal strengths, and pulse widths.

## Simplified Operation of the ECM System.

The ultimate output signal of the ECM system is a reasonable replica of the received radar signal but is subject to a variable time delay before retransmission. This time delay is sufficient to deceive the radar with erroneous range information.

A simplified ECM chain is shown in **Figure 3**. The input signal received from the illuminating radar is picked up by the receiving antenna of the ECM system. The amplifier chain of the system, covering a 0.5 to 1 octave band (depending on frequency), utilizes traveling-wave tubes for each of its amplifier stages. The received signal is amplified by the preamplifier stage which should have a noise figure low enough to accommodate the desired threshold or weakest signal.

The duration of the received signal is roughly equivalent to the reciprocal of the radar IF bandwidth. A portion of the amplified signal is then sent to the cascaded amplifier stages through a power splitter; the remaining preamplifier power is directed to the microwave storage memory circuit for signal processing. From this signal the feedback loop produces an output with a duration many

times that of the actual received signal. During this extension of the memorized signal, the low-level input amplifier is gated off the memory loop traveling-wave tube is turned on. The associated threshold and level sensing circuit of the system determine the appropriate time (contingent on signal delay and amplitude, etc.) at which to put the system in the memory mode. The output of the memory storage subsystem, stretched out in duration, is then amplified in the driver tube and final power amplifier stages.

Because of the widely different signal levels and signal processing requirements imposed on each of the stages by the ECM system, specialized traveling-wave tubes have been designed for each of the major functions in the cascaded chain. These major functions are:

- Low-level traveling-wave tube amplifier stage.
- Recirculating rf memory (Loop) traveling-wave tube stage.
- Driver traveling-wave tube stage.
- Final power amplifier traveling-wave tube stage(s).

To insure proper operation of the system, each amplifier stage must be capable of coping with the associated interface characteristics of adjacent stages. This criteria necessitates that each stage independently meet:

1. Minimum small-signal-gain requirements to insure that the threshold input signal will drive the final power output tube to the minimum system power output requirement.
2. Maximum small-signal-gain limits, if CW operation is utilized, because of the antenna-to-antenna isolation problems (receiver to transmitter) that otherwise might occur.
3. Minimum power output within the wide input power overdrive range.
4. The overall performance criteria with power supply regulation of  $\pm 0.5$  to  $\pm 2.0\%$ .
5. The overall performance criteria over the temperature and environmental extremes.
6. External mechanical requirements such as shock, vibration, accoustical noise, etc.
7. RFI and stability requirements.

RCA has developed an excellent design engineering and manufacturing capability which has concentrated on traveling-wave tubes of the first three low-power stages of the typical ECM system indicated in **Figure 3**. This capability, the result of many years of experience in supplying traveling-wave tubes for major ECM systems, has given RCA an important insight into the required tube characteristics, the associated operating interface, and the signal processing problems that must be resolved for each of the first three stages. The discussion below is limited to the low-level and memory traveling-wave tube stages because of the special requirements for these stages.

**The Input Traveling-Wave Tube.** The typical input traveling-wave tube of the ECM system must meet several diverse and conflicting requirements. It must have a noise figure low enough to make the threshold signal discernible and to establish the minimum signal-to-noise ratio of the system and yet it must simultaneously accommodate a wide range of input signal strengths (perhaps 30 to 50 dB beyond saturation) and meet minimum power output requirements.

RCA has designed medium-noise periodic permanent-magnet (ppm) traveling-wave tubes to meet customized system interface needs for a wide range of frequency. In general, these tubes cover L-X band and have noise figures ranging from under



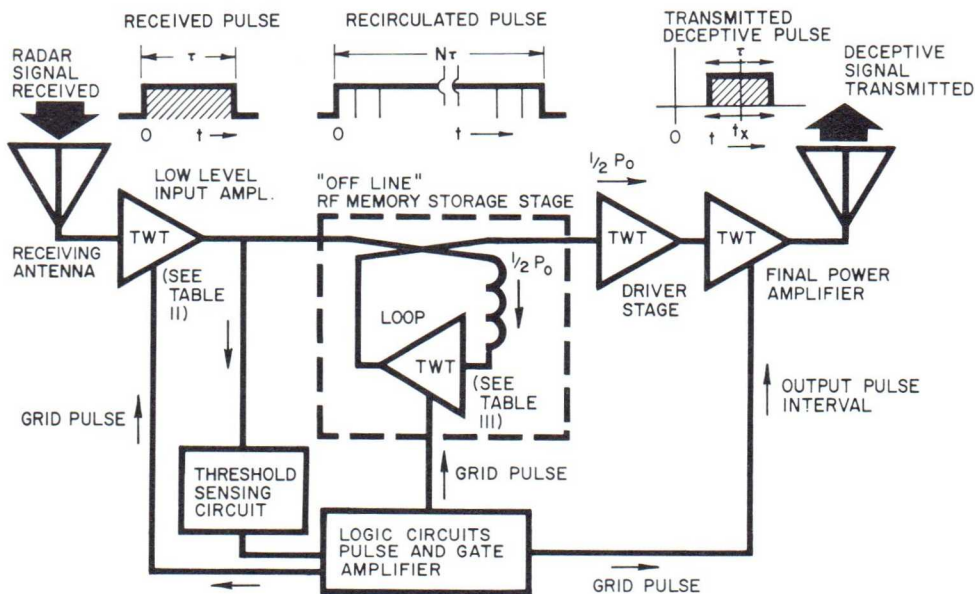

Figure 3 – ECM Receiver/Transmitter Chain

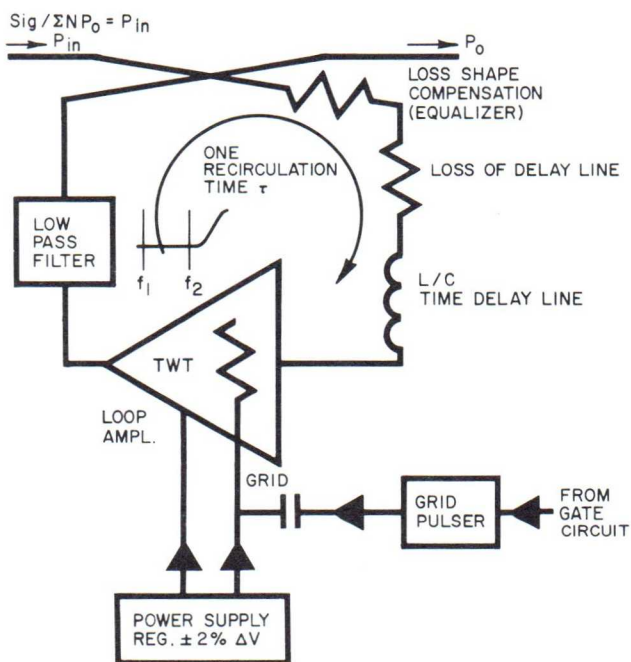

Figure 4 – Off Line Recirculating RF Memory Subsystem

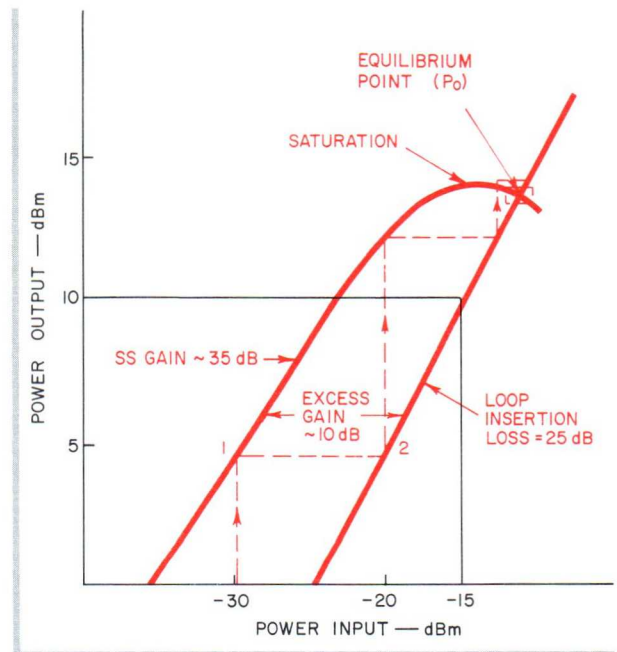

Figure 5 – Dynamic Loop and TWT Equilibrium Operating Point.

12 dB to approximately 20 dB. The salient characteristics of devices designed as input tubes for ECM systems are shown in **Table II**.

**Design of The Memory Storage Traveling-Wave Tube.** Operation of memory storage is obtained by feeding the output of the traveling-wave tube back into its input through an appropriate feedback circuit. **Figure 4** illustrates this action for an "off line" loop where the initiating pulse does not undergo amplification by the loop traveling-wave tube before being transmitted. The dynamic operation of this feedback loop, comprised of the traveling-wave tube, a coaxial or waveguide delay line, and other passive components, is so complex that the interrelationship of the various components must be fully understood before a satisfactory design criteria can be evolved.

To obtain memory performance and regeneration at any frequency in the band, the small-signal gain of the traveling-wave tube in the feedback loop must be in excess of the feedback losses in the frequency band. However, mere injection of a signal into the loop subsystem with the prerequisite gain is not sufficient to insure stable, long-term memory storage. Good operation of the memory traveling-wave tube and its feedback network require that many dynamic rf parameters be simultaneously satisfied.

**Overdrive Equilibrium Requirements.** Operation of a loop memory tube can be best illustrated by referring to the dynamic overdrive and loop loss curve shown in **Figure 5**. For the example shown, application of the threshold signal (-30 dBm) to the loop subsystem provides a tube power output of +5 dBm (Point 1). The excess loop gain (~ 10 dB), after the first recirculation, produces a new input power to the tube of -20 dBm (Point 2). This regeneration ideally occurs with each recirculation until the open loop gain is equal

to the loop loss and the system comes to rest at the equilibrium or quiescent storage point. Obviously, it is necessary to properly shape the overdrive curve to establish and to maintain stable memory operation at the equilibrium point. An improperly shaped overdrive curve with excessive power fall-off beyond saturation will cause faulty recirculation and "hunting" (bi-stable operating levels).

**Noise Capture and Gain Suppression.** The fact that the traveling-wave tube and feedback network are necessarily broadband, causes the "white" noise power of the input traveling-wave tube, amplified by its gain and the excess gain of the memory circuit, to be recirculated. This white noise can build up in each successive recirculation and virtually capture the memory system. Noise capture—one of the prevalent failure mechanisms in memory storage traveling-wave tubes—generates an erroneous signal independent of the desired coherent input frequency making the memory inoperative.

The excess gain, power output, and feedback phase relationship across the band will determine the single frequency (or finite band of frequencies) which will take over, or capture the recirculating memory. In the presence of a desired input signal, however, this failure mode—noise capture—must be avoided for the required term of memory storage.

Random noise capture of a broadband feedback loop is inhibited by a phenomenon known as "gain suppression." Gain suppression manifests itself, as it does with all active devices, in the presence of a large overdriving signal, by compressing the small-signal gain everywhere in the band. This characteristic is illustrated in **Figure 6**. In this figure the input/output characteristics of a traveling-wave tube at both the small-signal and saturation regions are given with varying levels of suppression signal elsewhere in the band.

It is quite apparent that large suppression signals will reduce the small-signal gain appreciably.

In a feedback loop, as the operating point converges toward equilibrium after the initiation of an input pulse, the excess feedback gain is reduced to zero (i.e. gain = losses). Obviously, the input power to the loop tube at equilibrium is sufficient to suppress the gain for all frequencies in the band. As a "rule-of-thumb," the degree of gain suppression for all noise frequencies is roughly equivalent to the gain suppression suffered by the coherent frequency itself in approaching its equilibrium point in the feedback circuit. The suppression of gain in a well-designed broadband traveling-wave tube by the larger coherent overdriving signal is sufficient to prevent build-up and capture of the memory by recirculating noise.

**The Delay Line.** A single recirculation delay time of the system is determined largely by the average width of the varied radar pulses it must accommodate.

For optimum performance, the total delay time for one recirculation must be roughly equivalent to the radar pulse duration. This delay time (150 - 250 nanoseconds including the 12-20 nanoseconds delay of the traveling-wave tube) typically may require 100-150 feet of coaxial cable. After establishing the cable length, the cable diameter and other parameters can be determined.

The attenuation (or feedback loss) of a delay line of fixed length is an inverse function of cable diameter. The desire to minimize the size and weight of a cable is compromised by the more pressing need to keep the overall feedback loss substantially below the small-signal gain of the traveling-wave tube. The difference between the small-signal gain and loss—10 to 15 dB—is the excess gain of the feedback loop. One, therefore, trades loop attenuation problems for size.



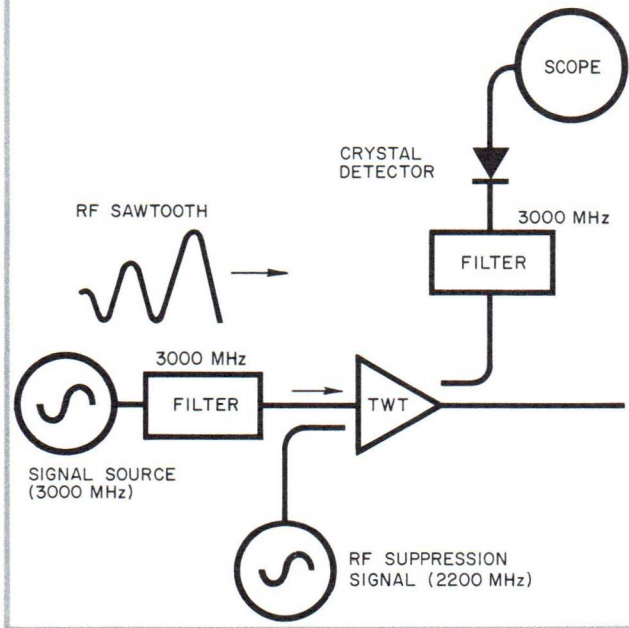
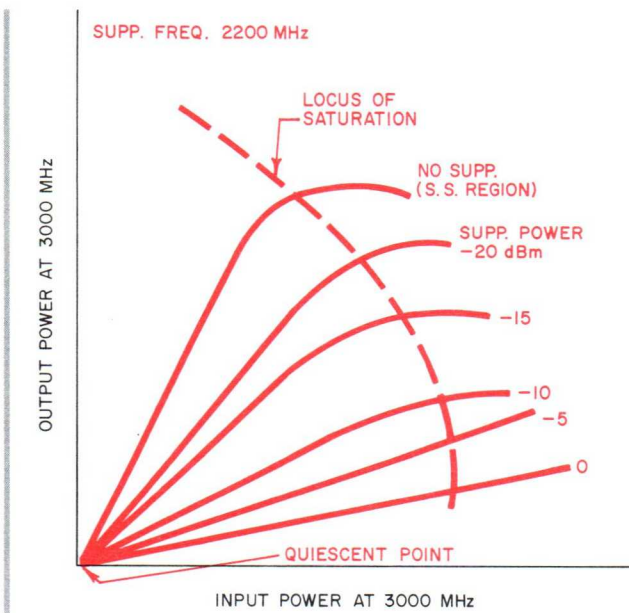

Figure 6 — Transfer Characteristics of a Traveling-Wave Tube in the Presence of a Suppression Signal at a Fixed Frequency

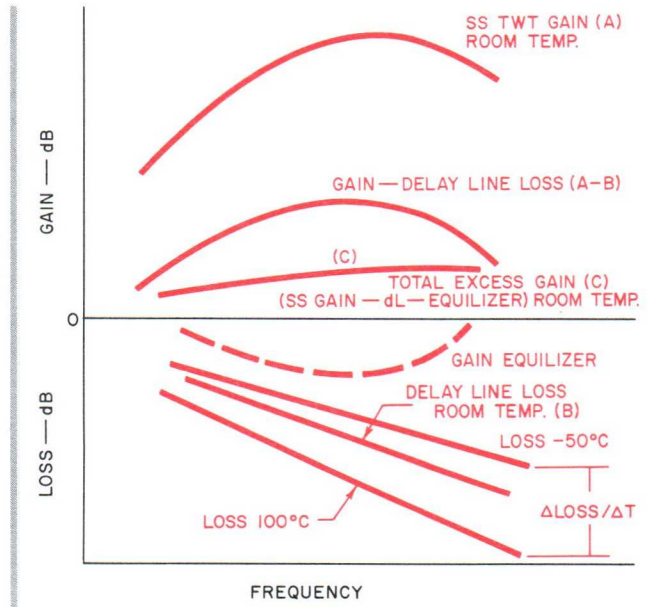

Figure 7 — Tube Gain Loop Loss Parameters as a Function of Frequency and Temperature

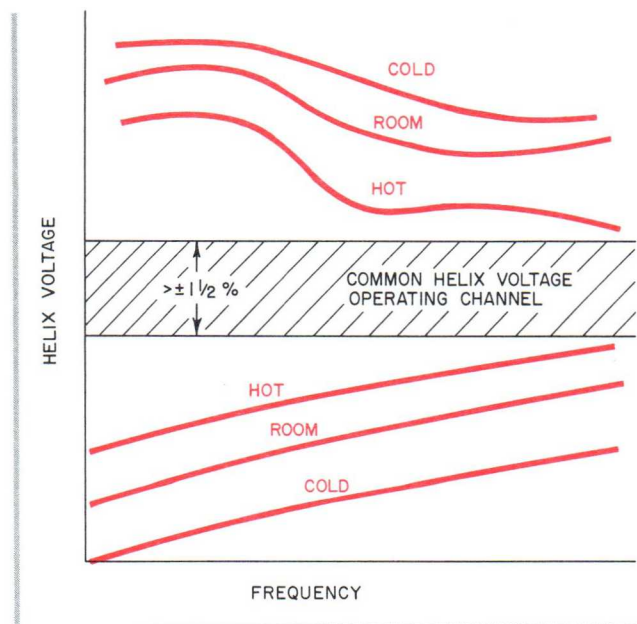

Figure 8 — Helix Mode Storage Plot vs Temperature

**Loss Equalization/Temperature.** The loss of the coaxial delay line increases linearly with frequency as shown in **Figure 7**. When this loss is subtracted from the typical small-signal gain characteristics of a traveling-wave tube, an excess gain shape results which is generally convex or humped at center frequency. This gain shape, far from ideal, provides recirculating noise with the opportunity to build up at center band where the gain predominates (independent of the signal input frequency) and sometimes causes faulty rf memory operation.

To avoid noise capture due to relatively high excess gain at mid band, a gain shaping equalizer can be used in series with the delay line. The reciprocal loss characteristic introduced by the equalizer is designed to compensate for the dome-shaped excess gain curve. The overall results at room temperature—a slightly rising excess-gain curve shown in **Figure 7** curve C—provides good memory storage operation.

Maintaining the desired excess gain shape is further complicated by the variations of delay-line loss with temperature. In general, delay-line losses track temperature linearly. An increase in temperature, therefore, causes losses to go up, while lowering temperature reduces losses. However, because the losses vary with frequency as well as temperature, the delay line covering an octave in frequency is likely to suffer twice the loss versus temperature variation at the high-frequency compared to the low-frequency end of the band. Although the absolute change in loss can be tolerated with sufficient excess gain, the attendant change in loss shape with temperature is conducive to noise capture.

**Mode Plots and Performance.** To test and demonstrate the capability of each loop traveling-wave tube, complex measurements are made of rf storage capability

over the range of conditions mentioned above. These measurements indicate the common range of power supply variation (helix voltage) that can be tolerated as a function of frequency while still meeting power output and other parameters during the storage cycle. A typical "mode plot" indicating the loci of satisfactory performance is shown in **Figure 8**. These data are repeated for hot and cold temperature and for extremes in the drive range. A tube is considered acceptable if it is able to meet the power supply regulation requirements (~1 to 2 per cent of helix voltage) as a common voltage channel for all conditions of operation.

Perturbations in the small-signal gain curve of the traveling-wave tube or in the feedback circuit can cause loss of memory over that frequency band. To inhibit such failures it is necessary to take excess-gain plots of all tubes and associated loops to establish that the proper contour and fine-grain performance levels have been achieved.

When the proper controls have been imposed on both tube and passive circuit components for fine-grain response, VSWR, gain loss contour, and overdrive, etc., tubes can be made which provide the required memory storage with all loops over a reasonable spread of characteristics.

**In-Line RF Memory Storage.** Loop memory storage tubes have been designed for specific systems where the functions of both cw amplification and rf memory are combined in a single stage. This approach replaces the drive tube shown in **Figure 3** with the so called "in-line" loop traveling-wave tube configuration shown in **Figure 9**.

This circuit simplification reduces the complexities of the system but imposes on the traveling-wave tube all of the rf characteristics needed for pulse amplification as well as the sophisticated characteristics required for rf memory storage. The traveling-wave tube in this sys-

tem must meet minimum and maximum system gain restraints, provide the proper input/output drive characteristics for the cw pulse and enable rf memory storage at a power level approximately one magnitude higher than that of the off-line traveling-wave tube.

**Prerequisites for Memory Storage.**

Traveling-wave tubes for loop memory subsystems must be designed to provide rf storage capability while operating with the required passive delay components in the feedback loop. To accomplish this, it is necessary for the traveling-wave tube to meet the following prerequisites.

1. Produce small-signal gain contour which complements the delay line loss.
2. Maintain excess gain spread and gain contour with temperature variation over operating environment.
3. Provide storage operation over the memory period with  $\pm 2$  per cent variations in power supply voltages and with the specified temperature variation.
4. Meet the requirements mentioned above over a wide input pulse power range.
5. For the in-line loop—meet the specific system interface characteristics as an amplifier between the input and final traveling-wave tubes in the chain as well as rf storage.

**RCA Memory Tubes.** RCA has built many different "in-line" and "off-line" traveling-wave tubes to meet a host of system requirements. Characteristics of some of the memory tubes available from RCA are tabulated in **Table III**.

**Power Supplies.** For quick-reaction time in meeting customer requirements, RCA can provide integral solid-state power supplies for most of the RCA ECM traveling-wave tubes. These power supplies are available in either field or depot repairable form for use in airborne or ground applications.



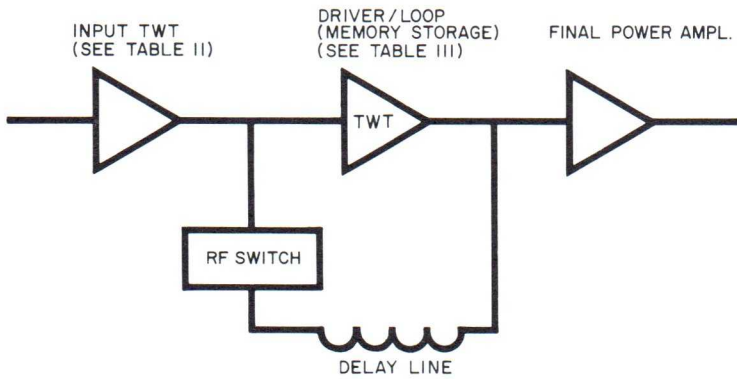

Figure 9 – In Line RF Memory Storage Subsystem

| Type No. | Frequency Range GHz | Min. Noise Figure dB | Min. Small-Signal Gain dB | Pulse Grid | Power Output Range dBm | Input Power Range dBm | 2nd Harmonic (Separation) dBc |
|----------|---------------------|----------------------|---------------------------|------------|------------------------|-----------------------|-------------------------------|
| A1350    | 1 – 2.6             | < 12                 | 30                        | x          | 0 to 20                | -43 to -7             | NA                            |
| A1327    | 2 – 4               | < 17                 | 36                        |            | +5 to +20              | -32 to +2             | -3                            |
| A1381    | 2 – 4               | ~ 25                 | 35                        | x          | +1 to +20              | -32 to +18            | -5                            |
| A1382    | 4 – 7.4             | < 20                 | 28                        | x          | -14 to +6              | -38 to +6             | -5                            |
| A1360    | 4 – 8               | ~ 15                 | 33                        |            | -3 to +15              | 28 to 0               | -5                            |
| A1383    | 7.4 – 12            | < 20                 | 28                        | x          | -14 to +9.5            | -38 to 8.5            | -5                            |
| A1422    | 8 – 12              | ~ 10                 | 30                        | x          | 10                     | -38 to 0              | -5                            |

Table II – RCA Low-Level Traveling-Wave Tube Characteristics

| Type No. | Performance Mode | Frequency Band | Grid Gate | Storage Time* | Power Level    | SS Gain   |
|----------|------------------|----------------|-----------|---------------|----------------|-----------|
| A1220    | Off-line         | S              | x         | A             | 10 – 80 mW     | Not req'd |
| A1361    | Off-line         | C              | x         | A             | 2 – 40 mW      | Not req'd |
| A1379    | Off-line         | X              | x         | B             | ~ 10 mW        | Not req'd |
| A1421    | Off-line         | Ku             | x         | B             | ~ 10 mW        | Not req'd |
| A1384    | In-line          | S              |           | A             | ~ 1 – 4 W      | 35 dB     |
| A1385    | In-line          | C              |           | A             | 100 mW – 1/2 W | 40 dB     |
| A1386    | In-line          | X              |           | A             | 100 mW – 1/2 W | 40 dB     |

\*Storage Time: A approx. 5  $\mu$ s B approx. 20  $\mu$ s

Table III – RCA Memory Storage Traveling-Wave Tube Characteristics

## RCA Traveling-Wave Tube Facilities

RCA has been actively involved in the research, design, development, and production of traveling-wave tubes and related electronic systems and equipment since 1951. During this period, the manufacturing operation has developed and matured to the point where RCA is now one of the leading producers in the industry. Our tubes are used in systems that are earth-bound, shipborne, airborne, and orbital. The types of systems include communications, radar, ECM, and test equipment.

In addition to the manufacture of traveling-wave tubes, we design and build our own test equipment, tools, fixtures, jigs, and processing equipment, because of the complexity of this device and its special requirements. For this purpose, we have a complete tool and equipment-design group whose sole function is to supply the needs of our manufacturing and development programs.

RCA experience in the design, construction, and use of traveling-wave tube test equipment dates back to the period when both the traveling-wave tube and its test equipment could only be supplied by developmental laboratories. Since then, RCA has directed its ability towards the supply of production quantities of traveling-wave tubes which have been accurately tested to modern system requirements on the latest equipment. Thus, RCA pioneered the development of the techniques and facilities required to perform reliable system testing of recirculator (loop) traveling-wave tubes.

The Microwave Tube Operations Department, located in Harrison, New Jersey, has 145,000 square feet of floor space including a machine shop, an equipment construction shop, clean assembly areas,

acceptance test areas, life and environmental test sections and chemical and physical laboratories for analytical services. The stringent requirements for production reliability, life, and performance has long been recognized by RCA. This need has led to the introduction of sophisticated approaches to product control and fabrication for advanced traveling-wave tubes, integrated "clean areas," system-oriented specifications, programmed control-tape manufacturing, computer design, etc. These modern facilities shown here illustrate RCA's current capability for the manufacture of traveling-wave tubes for both developmental and high-volume requirements.

**Environmental Control Assembly.** All internal sub-assemblies for RCA traveling-wave tubes are manufactured in Class II clean rooms in which the particle content, humidity and temperature are precisely controlled and whose construction conforms to the most rigid particle count standards. In these areas, it is mandatory that personnel adhere to the clean-room practices of wearing dust-free caps, frocks, and gloves.

**Exhaust Area.** The various processing operations required for traveling-wave tubes during exhaust cycle are performed on sophisticated pumping stations which rigidly control the various parameters of vacuum pressure, temperature and electrical energy. The performance characteristics of each tube are continually monitored and recorded. Double bake-out facilities are utilized to control the atmosphere for processing metal-ceramic traveling-wave tubes in production.

**Aging and Stabilization.** Every traveling-wave tube amplifier receives an extended

aging and stabilization process prior to initial electronic testing and all tubes are subsequently quality tested after a minimum one-week quality holding period.

**Assembly and Focusing Structures.** RCA has multiple production facilities for the magnetization of periodic permanent-magnetic-focusing discs for each traveling-wave tube. Every magnetic structure is measured by automated magnetic probing equipment and each recorded field plot is inspected to rigid quality control standards. In addition, each magnetic assembly is subjected to thermal cycling to ensure stability of the magnetic circuit.

**Final Assembly.** The fabrication of the rf coupling circuit and external attenuation, the encapsulation, and the final finishing operations are all performed in environmental control areas by skilled personnel under rigid quality control manufacturing procedures.

**Environmental Testing.** Each type of RCA traveling-wave tube undergoes complete environmental testing and evaluation for vibration, shock, altitude, humidity, temperature and salt spray in accordance with applicable MIL Stds.

**Electronic Characteristic Testing.** Each traveling-wave tube is given a complete electrical test on modern automated test equipment. Each test set is specifically designed to measure all performance requirements under hot and cold operating conditions. Calibration of all test equipment is performed on a scheduled basis with traceability of calibration standards to the National Bureau of Standards. Completed test data is supplied with every traveling-wave tube.



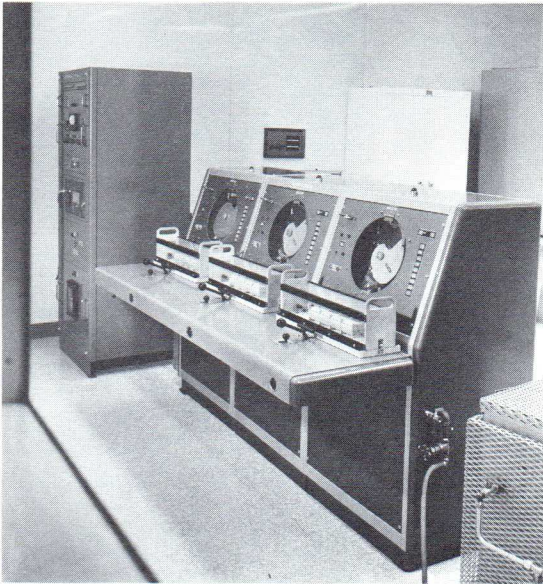

RCA-designed , A System for Sealing Elements in Tubes

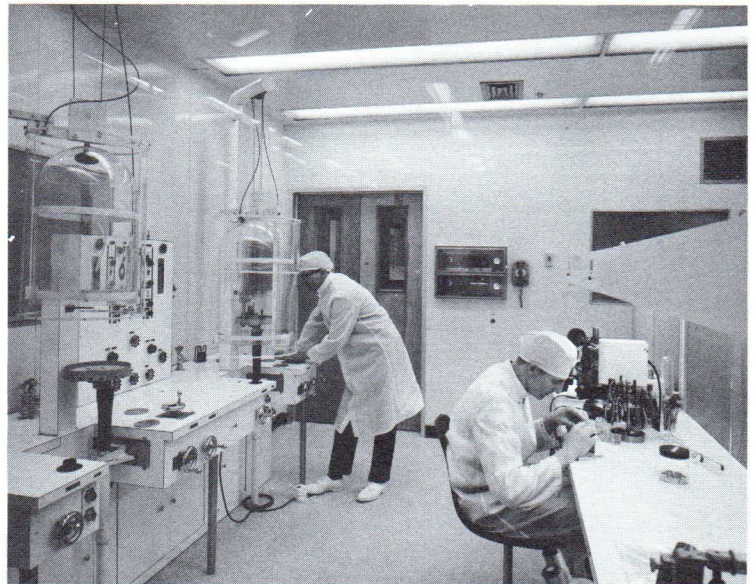

Tube exhaust and assembly area.



Electronic micrometers for high-precision, three-dimensional measurements in Incoming Inspection department.



X-ray for measuring grid and cathode spacing.



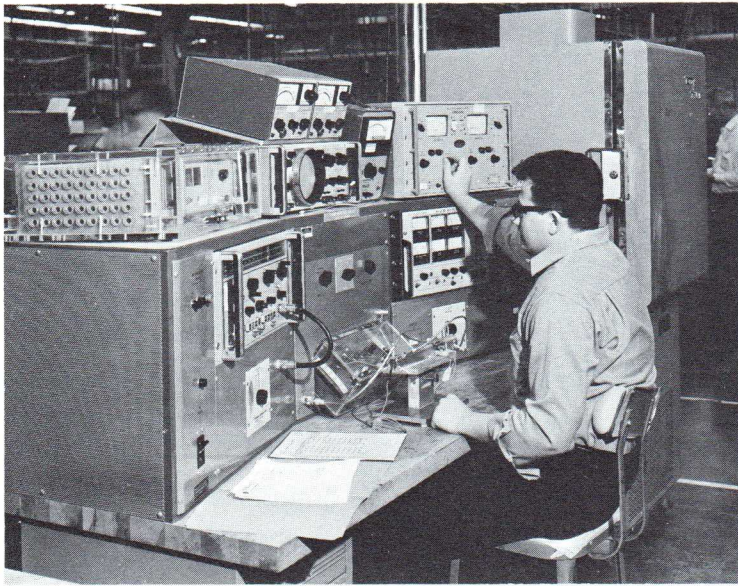

Traveling-wave tube characteristics test set with temperature chamber.

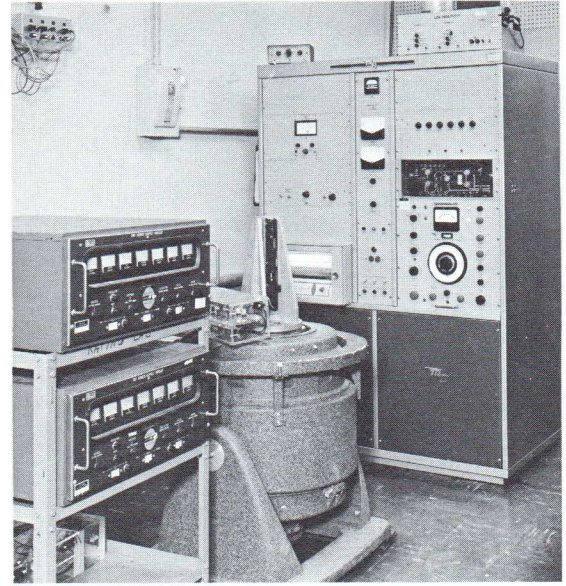

TWT mounted on programmed vibration test machine.

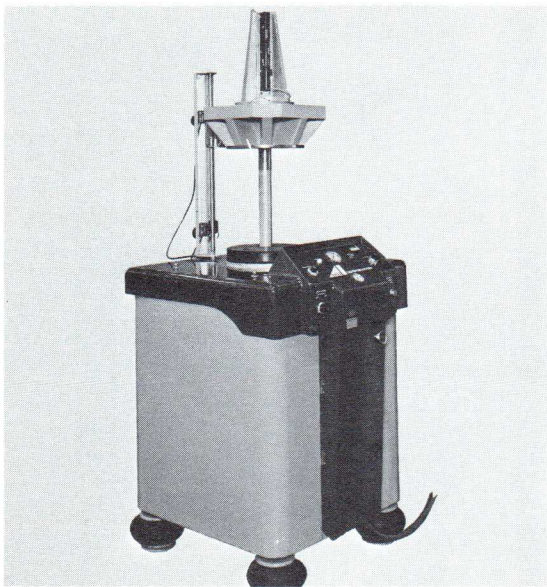

TWT mounted on shock-test machine.

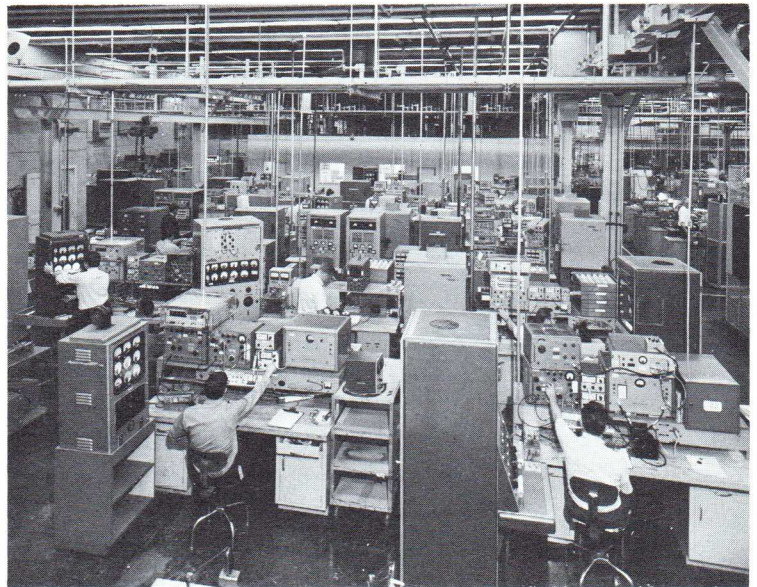

Traveling-wave tube test area.



## RCA Sales Offices

|                             |                  |   |                |
|-----------------------------|------------------|---|----------------|
| <b>CALIFORNIA</b>           | Los Angeles      | 6363 Sunset Blvd., Hollywood, CA 90028                      | (213) 461-9171 |
|                             | San Diego        | 7969 Engineer Rd., Suite 216, San Diego, CA 92111           | (714) 279-0420 |
|                             | San Francisco    | 343 Sansome St., 7th Floor, San Francisco, CA 94104         | (415) 956-4818 |
|                             |                  | 4546 El Camino Real, Los Altos, CA 94022                    | (415) 948-8996 |
| <b>COLORADO</b>             | Denver           | 2785 N. Speer Blvd., Room 346, Denver, CO 80211             | (303) 433-8841 |
| <b>DISTRICT OF COLUMBIA</b> |                  |   |                |
| <b>COLUMBIA</b>             | Washington       | 1725 "K" St., N.W., Washington, DC 20006                    | (202) 337-8500 |
| <b>FLORIDA</b>              | Palm Beach       | 2828 Broadway, Riviera Beach, FL 33404                      | (305) 842-1577 |
|                             |                  |   | (305) 842-2171 |
| <b>GEORGIA</b>              | Atlanta          | RCA Bldg., 14 Executive Park Drive, N.E., Atlanta, GA 30329 | (404) 634-6131 |
| <b>ILLINOIS</b>             | Chicago          | 446 E. Howard Ave., Des Plaines, IL 60018                   | (312) 827-0033 |
| <b>INDIANA</b>              | Fort Wayne       | Maplewood Plaza, Suite 207, 6012 Stellhorn Rd.,             |                |
|                             |                  | Ft. Wayne, IN 46805   | (219) 485-9683 |
|                             | Indianapolis     | 501 N. LaSalle St., Indianapolis, IN 46201                  | (317) 635-9000 |
|                             |                  | 2511 E. 46th St., Suite Q1, Atkinson Sq.,                   |                |
|                             |                  | Indianapolis, IN 46205                                      | (317) 546-4001 |
| <b>MASSACHUSETTS</b>        | Boston           | 360 First Ave., Singer Bldg., Needham Heights, MA 02194     | (617) 444-8492 |
|                             |                  | 150 "A" St., Needham Heights, MA 02194                      | (617) 444-7200 |
| <b>MICHIGAN</b>             | Detroit          | 28840 Southfield Rd., Lathrup Village, MI 48075             | (313) 353-9770 |
| <b>MINNESOTA</b>            | Minneapolis      | 6750 France Ave. S., Suite 122, Minneapolis, MN 55435       | (612) 929-0676 |
| <b>MISSOURI</b>             | Kansas City      | 7711 State Line, Suite 112, Kansas City, MO 64114           | (816) 363-1720 |
|                             |                  |   | (816) 363-6462 |
| <b>NEW JERSEY</b>           | Camden/Phila.    | 605 Marlton Pike, Haddonfield, NJ 08034                     | (609) 428-4802 |
|                             | North Jersey     | Central and Terminal Avenues, Clark, NJ 07066               | (201) 485-3900 |
| <b>NEW YORK</b>             | Metropolitan NYC | Central and Terminal Avenues, Clark, NJ 07066               | (201) 485-3900 |
|                             | Long Island      | 550 Old Country Rd., Hicksville, L.I., NY 11803             | (516) 935-5240 |
|                             | Syracuse         | 731 James St., Room 206, Syracuse, NY 13203                 | (315) 474-8221 |
|                             |                  |   | (315) 479-8134 |
| <b>OHIO</b>                 | Cleveland        | 1621 Euclid Ave., 1600 Keith Bldg., Cleveland, OH 44115     | (216) 579-0880 |
|                             | Dayton           | 224 N. Wilkinson St., Dayton, OH 45402                      | (513) 461-5420 |
| <b>TEXAS</b>                | Dallas           | 210-C Court Terrace, Exchange Park N., Dallas, TX 75235     | (214) 351-5361 |
|                             | Houston          | 2727 Allen Parkway, Suite 2170 American General Bldg.,      |                |
|                             |                  | Houston, TX 77019   | (713) 529-7601 |
| <b>WASHINGTON</b>           | Seattle          | 2246 First Avenue S., Seattle, WA 98134                     | (206) 622-8350 |

| Distributor | Equipment | Government |
|-------------|-----------|------------|
| •           | •         | •          |
|             | •         |            |
| •           |           |            |
|             | •         |            |
| •           |           |            |
|             |           |            |
| •           | •         | •          |
|             | •         |            |
| •           |           |            |
|             |           |            |
| •           | •         |            |
|             | •         |            |
| •           |           |            |
|             |           |            |
| •           |           |            |
|             |           |            |
| •           | •         |            |
|             | •         |            |
| •           |           |            |
|             |           |            |
| •           | •         |            |
|             | •         |            |
| •           |           |            |
|             |           |            |
| •           |           |            |
|             |           |            |
| •           |           |            |
|             |           |            |
| •           |           |            |
|             |           |            |

### International

|                 |                  |  |                |
|-----------------|------------------|--|----------------|
| <b>U.S.A.</b>   | Harrison, N. J.  | International Marketing, P.O. Box 270, Harrison, NJ 07029        | (201) 485-3900 |
| <b>CANADA</b>   | Montreal, Quebec | 1001 Lenoir St., Montreal 30, Quebec                             | (514) 933-7551 |
| <b>EUROPE</b>   | Geneva,          |  |                |
|                 | Switzerland      | 2-4, rue du Lièvre, 1227 Acacias-Geneva, Switzerland             | 43 58 00       |
|                 | London, England  | Lincoln Way, Windmill Rd., Sunbury-on-Thames, Middlesex, England | 85511          |
| <b>FAR EAST</b> | Hong Kong        | 1927 Prince's Bldg., P.O. Box 112, Chater Rd., Hong Kong         | 23 41 81       |



RCA

# Traveling-Wave Tubes and Subsystems

