

Specification MAP/CV427	<u>SECURITY</u>	
Issue 2; Dated 28. 5.52.	<u>Specification</u>	<u>Valve</u>
To be read in conjunction with K1001	UNCLASSIFIED	UNCLASSIFIED

→ Indicates a change

TYPE OF VALVE - Pulse Modulator Tetrode CATHODE - Indirectly Heated ENVELOPE - Glass, unmetallised PROTOTYPE - VX7016; 715E		<u>MARKING</u> See K1001/4	
		<u>BASE</u> See Drawing on Page 4, B.4A	
<u>RATINGS</u>		<u>CONNECTIONS</u>	
		Note	Pin Electrode
Heater Voltage	(V) 26		1 Heater
Heater Current	(A) 2.0		2 Screen Grid
Max. Anode Voltage	(kV) 17.5		3 Control Grid
Max. Negative Control Grid Voltage	(kV) 1		4 Heater & Cathode
Max. Peak Positive Control Grid Voltage	(V) 300		T.C. Anode
Max. Screen Grid Voltage	(kV) 1.25		
Max. Screen Grid Voltage, (Ia = 0)	(kV) 1.35	A	
Max. Anode Dissipation	(W) 60		
Max. Peak Anode Current	(A) 15	B	
Max. Screen Grid Dissipation	(W) 8		
		<u>TOP CAP</u> See Drawing, Page 4.	
		<u>DIMENSIONS</u> See Drawing, Page 4.	
<u>CAPACITANCES (PF)</u>			
Cag (Max.)	2		
Cge	37		
Cae	7.5		

NOTES

- A. Screen Grid potential should not exceed 1.25 kV during operation. Minimum series resistance = 20,000 ohms.
- B. For duty cycle not greater than 0.001. With peak currents in excess of 5A the product of the current in amperes, and pulse duration in microseconds should not exceed 30. The valve should not operate for longer than 5 microseconds in any 100 microseconds period.

To be performed in addition to those applicable in K1001.

Test Conditions						Test	Limits		No. Tested	Note					
							Min.	Max.							
a						<u>CAPACITANCE (pF)</u>									
						1. Cag						-	2	6	
						2. Cge						30	45	per	
						3. Cae						5	10	week	
b						Vh (V)	Va (kV)	Vg2 (kV)	Ia (mA)	Vg1 (V)	Ih (A)	1.95	2.35	100% or S	
c						27	0	0	0	0	Reverse Ig1 (μA)	0	20	100%	1
d						27	1.2	1.0	50	Adjust	Ig2 (mA)	0.5	6.0	100% or S	
e						27	1.2	1.0	50	-	Vg (V)	-190	+290	100%	
f						27	1.2	1.0	1.0	-	Vg (V)	-	+4.00	100%	
g						27	1.2	1.0	-	-500	Reverse Ig1 (μA)	0	4.0	100%	
h						25	20	1.25	-	-800	Ia (Peak) Ig2 (Mean)	15	-	100%	2
						Never Negative									

NOTES

1. Valve shall operate with constant, or decreasing, grid current for 2 minutes. It shall become constant, or decrease, in 5 minutes.
2. A pulse of length 2 micro-seconds, and repetition rate of 300 - 500 per sec. with a variation in amplitude over 80% of the top portion of the pulse not greater than 5%, shall be applied to drive the control grid positive by 225 ± 25 V at the top of the pulse. The variation in amplitude of output pulse to be not greater than 10% and during the test there shall be no sustained sparking. Duration of test 2 minutes. The test circuit is shown on page 3.

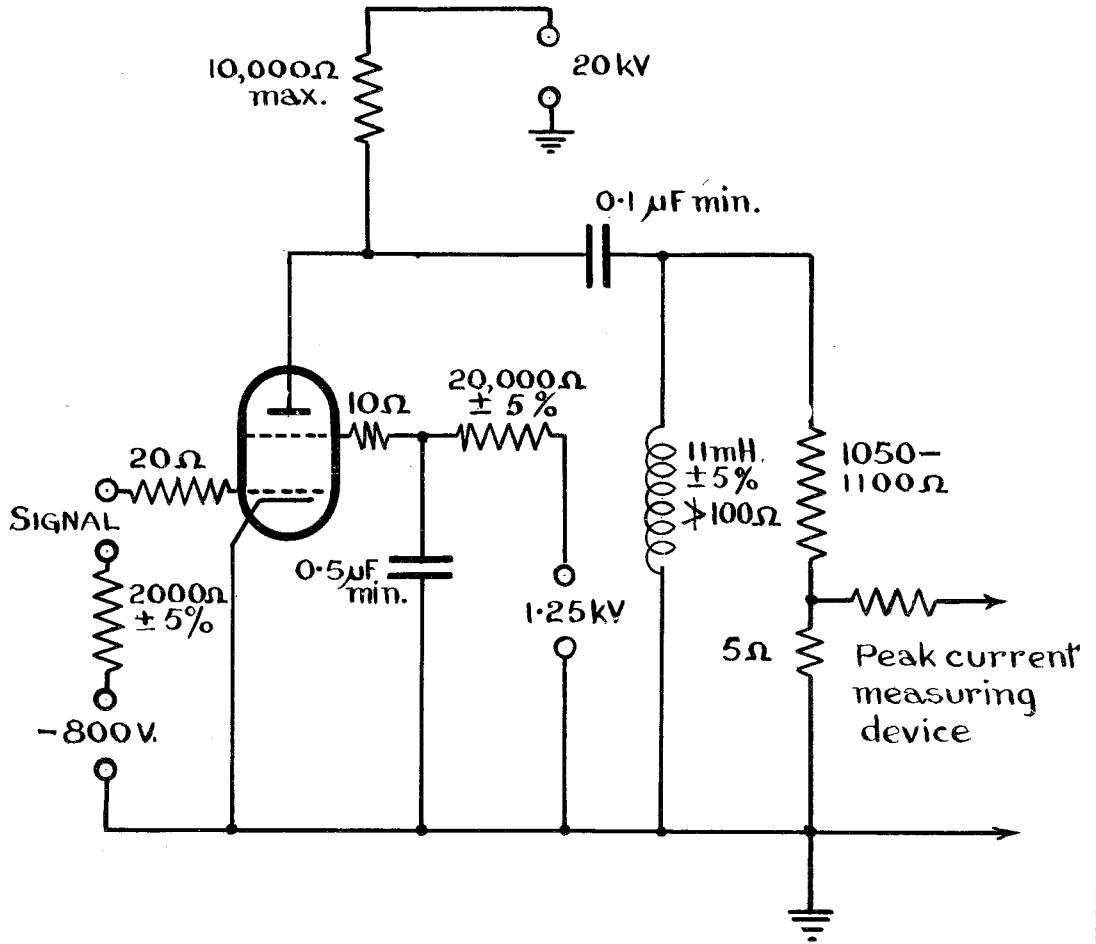

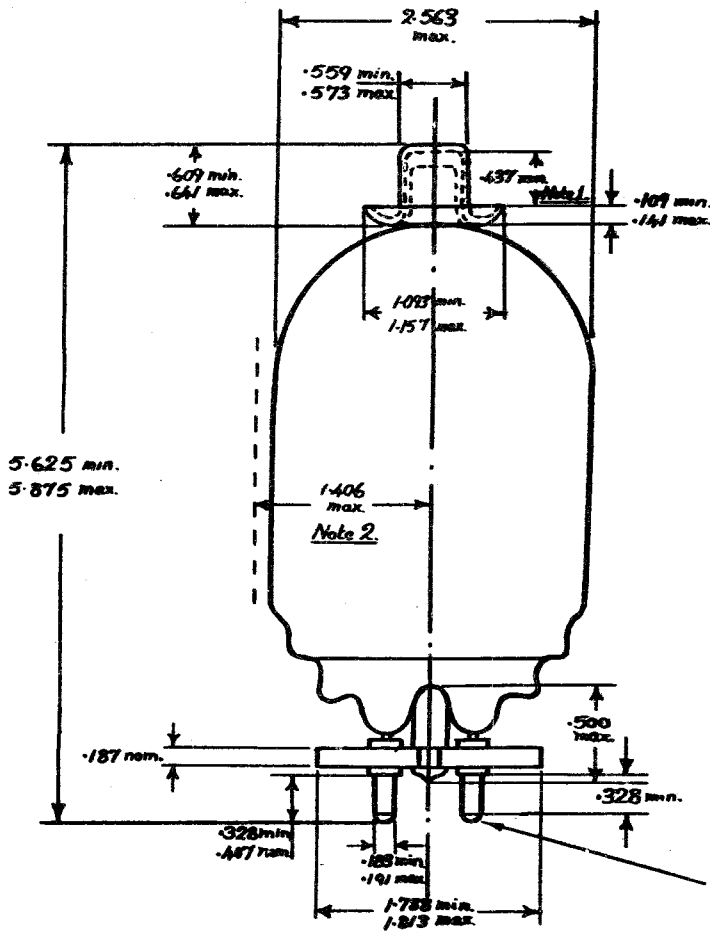

SOLDER SHOULD NOT EXTEND LATERALLY BEYOND CYLINDRICAL SURFACE OF STUDS

THE BASE SHALL BE CAPABLE OF ENTERING A GAUGE $\frac{1}{8}$ " THICK HAVING 4 HOLES WHOSE DIAMETERS ARE .214 AND WHICH ARE LOCATED ON $\frac{1}{16}$ " CENTRES.

NOTE 1. STRAIGHT SIDE OF TOP CAP

NOTE 2. ECCENTRICITY WITH RESPECT TO ϕ OF BASE

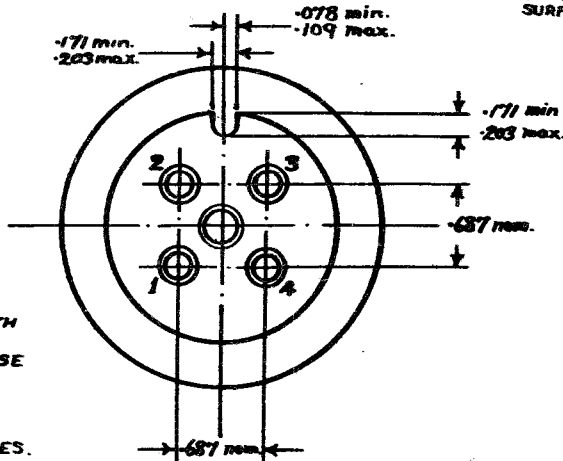

ALL DIMENSIONS ARE IN INCHES.