

ELECTRONIC VALVE SPECIFICATIONS

SPECIFICATION CV.2666

ISSUE 4 DATED 28.10.52

AMENDMENT NO.1

Page 3 Note 2

The sentence (in the middle of this note) "Angles  
to be within  $\pm 5^{\circ}$ " should be amended to read  
" $\pm 5'$  (minutes)".

Royal Aircraft Establishment.

December, 1958.

N.44548

MINISTRY OF SUPPLY D.L.R.D.(A)/R.A.E.

Specification MOSA./CV2666 Issue 4 Dated 28.10.52 To be read in conjunction with K.1001	<u>SECURITY</u>	
	<u>Specification</u> UNCLASSIFIED	<u>Valve</u> UNCLASSIFIED

→ Indicates a change

TYPE OF VALVE - R.F. Double Beam Tetrode		<u>MARKING</u> See K.1001/4	
CATHODE - Indirectly heated		<u>BASE</u> B7A See Drawing on Page 4	
ENVELOPE - Glass, Unmetallised			
PROTOTYPE - 829B			
<u>RATINGS</u>		Note	<u>CONNECTIONS</u>
Heater Voltage (V)	6.3	A	Pin Electrode
Heater Current (A)	2.25		
Max. Anode Voltage (V)	750	B	1 Heater
Max. Grid Voltage (V)	-175		2 Control Grid (b)
Max. Grid Current (mA)	7.5	C	3 Screen Grid
Max. Screen Grid Voltage (V)	225		4 Cathode, Beam Plates
Max. Anode Dissipation (W)	20	C	5 Heater, centre tap
Max. Screen Dissipation (W)	6.5	C	6 Control Grid (a)
Mutual Conductance (mA/V)	1.9	D	7 Heater
Anode Impedance (kΩ)	67	D	T.C.1 Anode (a)
Inner $\mu$ ( $g_1 - g_2$ )	5.6	D	T.C.2 Anode (b)
Max. Frequency, full ratings (Mc/s.)	200		<u>DIMENSIONS</u> See Drawing on Page 4
Max. Frequency, half ratings (Mc/s.)	300		
<u>CAPACITANCES (pF)</u>			
Cag Max.	0.12	C	
Cge Nom.	14.5	C	
Cae Nom.	6.95	C	
Cg2c Max.	65		
<u>NOTES</u>			
A. Centre tapped 12.6V. heater.			
B. Forced air cooling required.			
C. Each section.			
D. Measured at $V_a = 300V$ . $V_{g2} = 250$ , $I_a = 25$ mA.			

To be performed in addition to those applicable in K.1001

Test Conditions					Test	Limits		No. Tested	Note	
						Min.	Max.			
See K.1001/AIII Adaptor Type 43 Ref. 10H/13339.										
	Links to H.P.	Links to L.P.	Links to E.		<u>Capacitances (pF)</u>					
	T.C.1.	6	1,2,3,4,5,7, 8,9,10, T.C.2.		Ca(a)g1(a)	-	0.12	T.A.	2	
a	6	1,3,4,5, 7.	2,8,9,10, T.C.1, T.C.2.		Cg1(a)e	12.8	16.2	6 per Week		
	T.C.1.	1,3,4,5, 7.	2,6,8,9,10, T.C.2.		Ca(a)e	5.2	8.7			
	T.C.2.	2	1,3,4,5,6,7, 8,9,10, T.C.1.		Ca(b)g1(b)	-	0.12	T.A.	2	
	2	1,3,4,5, 7.	6,8,9,10, T.C.1, T.C.2.		Cg1(b)e	12.8	16.2	6 per Week		
	T.C.2.	1,3,4,5, 7.	2,6,8,9,10, T.C.1.		Ca(b)e	5.2	8.7			
	Vh	Va	Vg2	Vg1	Ia(mA)					
b	6.3	100 Volts applied to cathode and heater through a series resistor 100,000 ohms max.				H - C Leakage Current (μA)	-	175	100%	
c	6.3	0	0	0	0	Ih (A)	2.0	2.5	100% or S	
d	6.3	400	225	-	50	Reverse 1g1 (μA)	-	-4.0	100%	1
e	6.3	250	175	-11	-	1g2 (mA)	-	10.0	100% or S	1
f	6.3	250	175	-11	-	Ia (mA)	38	82	100%	1
g	6.3	400	225	-	0.2	Vg1 (V)	-	-55	100%	
h	6.3	Anodes, grids and screen grids strapped with 25 V D.C. applied.				Emission Current (mA)	250	-	100%	
j	6.3	400	225			<u>Oscillation Test</u> Output (W)	45	-	100%	
To be carried out at a frequency of 200 Mc/s in a push pull circuit Ia = 250 mA; Ig1 = 10 - 15 mA; Ig2 = 35 mA(max.); Rg1 = 5000 - 1500 ohms.										
<u>NOTES</u>										
1. Test to be applied to each half of the valve, control grid of unit not under test to be connected to -100 V.										
2. Cag to be measured with a metal shield $\frac{3}{4}$ " high and I.D. $2\frac{3}{8}$ ".										

DRAWING NOTES

1. The axis YY' is defined as the axis of the base pin gauge described in Note 2.
2. The valve base should be capable of entering to a distance of 0.375", a flat plate gauge having six holes 0.080"  $\pm$  0.0005 and one hole 0.1450"  $\pm$  0.0005", all arranged on a 1.000"  $\pm$  0.0005 circle at specified angles on the outline. Angles to be within  $\pm$  5°. A hole 0.500"  $\pm$  0.01" at the centre of the pin circle is also required. The axis YY' is defined by the centre of this hole.
3. Dimension "C" is measured by inserting the tube in the base pin gauge described in Note 2, and then lowering over the valve envelope a gauge plate having a hole 2.063" - 0.000 + 0.003" in diameter until the plate rests on the seal flange at position XX'. The centre line of the hole shall be coincident with the axis YY' within 0.150. With the gauge plate parallel to the top surface of the base pin gauge, the dimension "C" is measured between the bottom surface of the gauge plate and the top surface of the base pin gauge. This distance shall be 0.844 min. and 1.219 max.
4. Minimum diameter of the valve-seal flange will be such that a ring gauge having I.D. = 2.125" + 0.003" - 0.000 and thickness of 0.125"  $\pm$  0.010" will not pass the flange when tried at any angle.
5. The anode-leads shall be capable of entering a flat gauge plate of 0.375" min. thickness having two holes 0.120  $\pm$  0.0005" in diameter arranged 0.424  $\pm$  0.001 from a point coincident with the axis YY'. The axis of the holes shall be parallel to YY' and the plane of these axis shall be 90°  $\pm$  5° from the plane through YY' and Pin No. 4.

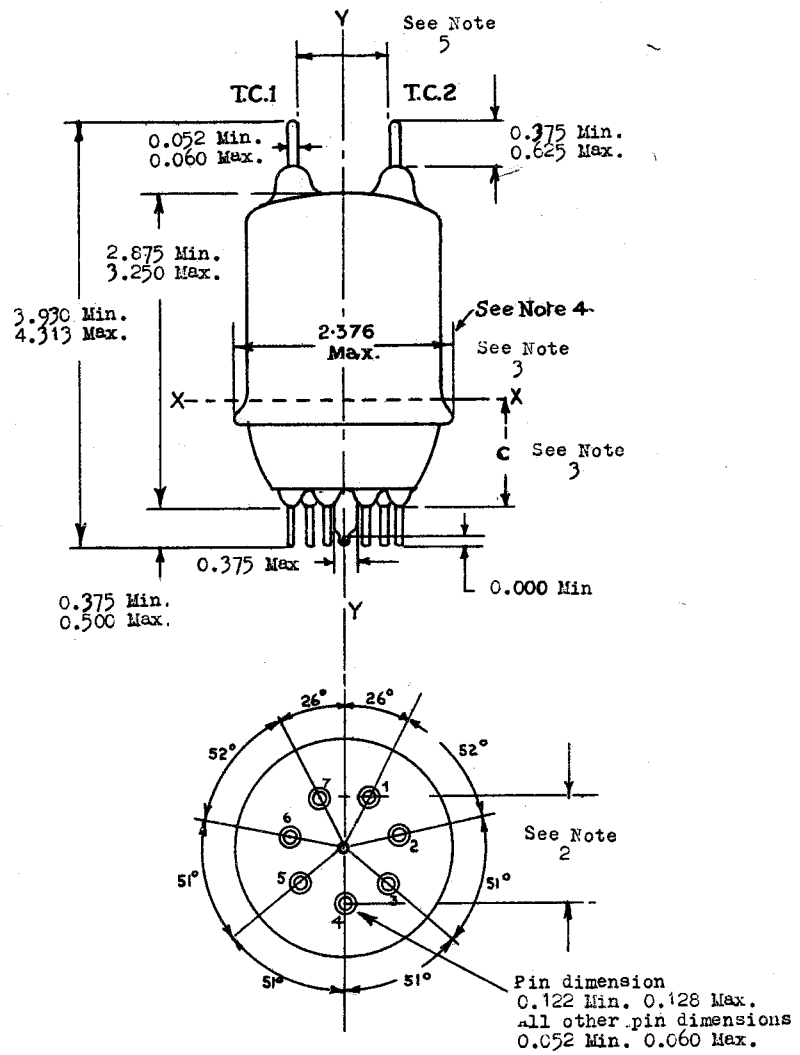

All dimensions are in inches. Drawing notes on Page 3.