

INSTRUMENT CATHODE-RAY TUBE

- 14 cm diagonal rectangular flat face
- domed mesh post-deflection acceleration
- high sensitivity and high line brightness (writing speed)
- high precision by internal permanent magnetic correction system
- internal graticule
- low heater power consumption
- for compact oscilloscopes with up to 100 MHz bandwidth

QUICK REFERENCE DATA

Final accelerator voltage	$V_{g7(l)}$	10 / 16.5 kV
First accelerator voltage	V_{g4}	2 / 2.2 kV
Minimum useful scan area		100 mm x 80 mm
Deflection coefficient		
horizontal	M_x	8 / 8.3 V/cm
vertical	M_y	4 / 4 V/cm

OPTICAL DATA

Screen type	metal-backed phosphor GH
colour	green
persistence	medium short
Useful screen area	≥ 102 mm x 82 mm (note 1)
Useful scan area	≥ 100 mm x 80 mm
Internal graticule	type 123 (see Fig.4)

HEATING

Heater voltage indirect by AC or DC *	V_f	6.3 V
Heater current	I_f	0.1 A
Heating time to attain 10% of the cathode current at equilibrium conditions (approx.)		7 s

* not to be connected in series with other tubes.

MECHANICAL DATA

Dimensions and connections (see also outline drawings)

Overall length (including socket)	≤ 338 mm
Faceplate dimensions	118 ± 0.5 mm x 98 ± 0.5 mm

Net mass approx. 1 kg

Base 12 pin, all glass, JEDEC B12-246

Final Accelerator Contact JEDEC J1-21

Mounting

The tube can be mounted in any position. It must not be supported by the socket and not by the base region alone. The reference points on adjoining edges of the faceplate (see Fig.4) enable the tube to be positioned accurately in the front panel, for optimum alignment of the internal graticule.

Accessories

Pin protector (required for shipping)	supplied with tube
Socket with solder tags	type 55594
Socket with printed-wiring pins	type 55595
Final accelerator contact connector	type 55465/66 (JEDEC J1-21)
Mu-metal shield	type 55458/55459 with end rubber 55460

FOCUSING electrostatic

DEFLECTION double electrostatic

x-plates symmetrical

y-plates symmetrical

CAPACITANCES

x_1 to all other elements except x_2	$C_{x1(x2)}$	4.8 pF
x_2 to all other elements except x_1	$C_{x2(x1)}$	3.6 pF
y_1 to all other elements except y_2	$C_{y1(y2)}$	3.0 pF
y_2 to all other elements except y_1	$C_{y2(y1)}$	3.0 pF
x_1 to x_2	C_{x1x2}	3.3 pF
y_1 to y_2	C_{y1y2}	1.4 pF
Control grid to all other elements	C_{g1}	6.5 pF
Cathode to all other elements	C_k	3.2 pF
Focusing electrode to all other elements	C_{g3}	8 pF
Final accelerator electrode to all other elements	C_{g7}	480 pF

DIMENSIONS AND CONNECTIONS

Dimensions in mm

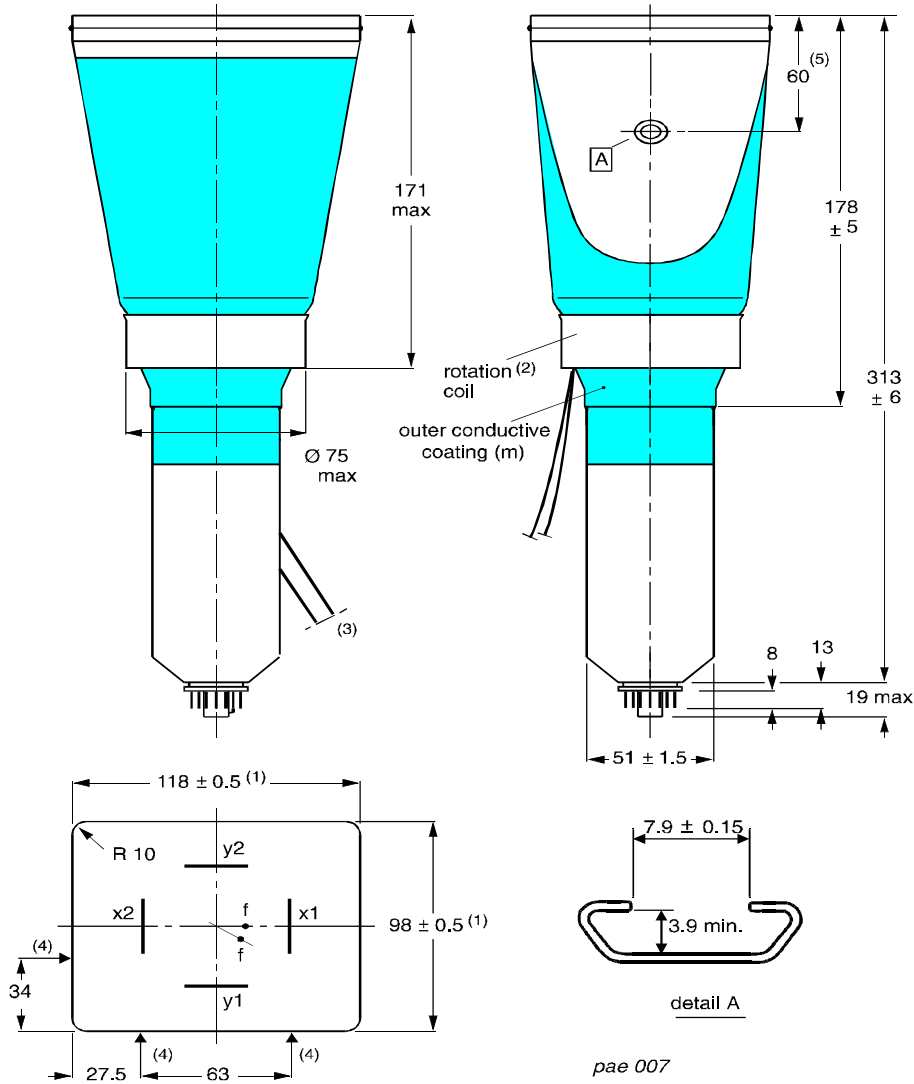

- (1) Dimensions of faceplate only. The complete assembly of faceplate and cone (frit seal included) will pass through an opening of 122 mm x 102 mm (diagonal 153 mm).
- (2) The coil is fixed to the envelope with resin.
- (3) The length of the rotation coil connecting leads is minimum 350 mm.
- (4) Reference points on faceplate for graticule alignment (see Fig.4)
- (5) The centre of the final accelerator contact is situated within a square of 10 mm x 10 mm around the indicated position.

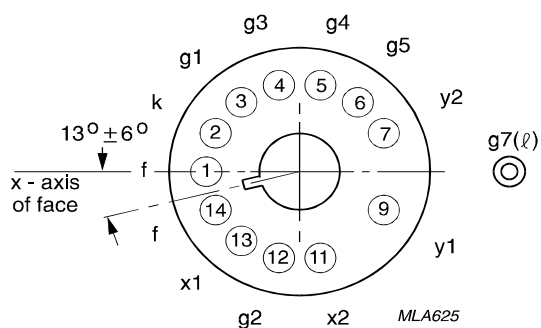

Fig.2 Pin arrangement, bottom view.

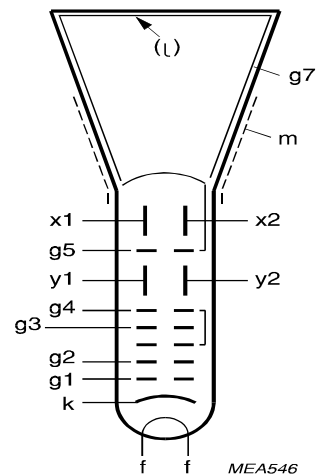

Fig.3 Electrical configuration.

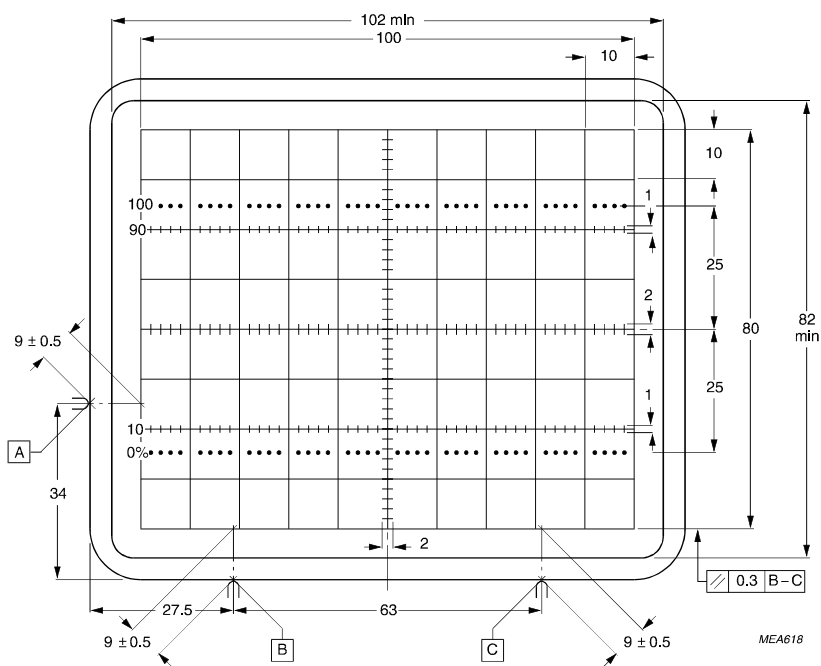

Fig.4. Front view of tube with internal graticule, type 123.

Reference points A,B and C are for aligning the graticule with the faceplate. Line thickness = 0.18 mm; dot diameter = 0.38 mm; colour: red.

TYPICAL OPERATION (voltages with respect to cathode)**Conditions**

Final accelerator voltage	$V_{g7(l)}$	10 / 16.5 kV	
Mean deflection plate potential		2 / 2.2 kV	note 2
Shield voltage for optimum geometry	V_{g5}	2 / 2.2 kV	note 3
First accelerator and astigmatism control voltage	V_{g4}	2 / 2.2 kV	note 3
Focusing voltage	V_{g3}	$0.19 \times V_{g4}$ to $0.26 \times V_{g4}$	
Grid 2 voltage	V_{g2}	2 / 2.2 kV	note 9
Cut-off voltage for visual extinction of focused spot	$-V_{g1}$	45 to 90/50 to 100 V	

Outer conductive coating (m) and mu-metal shield to be earthed.

PERFORMANCE

Deflection coefficient

horizontal	M_x	8.0/8.3 V/cm \pm 10%	
vertical	M_y	4.0/4.0 V/cm \pm 5%	
Deviation of deflection linearity		\leq 2%	note 4
Geometry distortion			notes 5,6
Eccentricity of undeflected spot			
in horizontal direction		\leq 4 mm	
in vertical direction		\leq 2 mm	
Angle between x- and y- traces		$90 \pm 0.5^\circ$	note 5
Angle between x-trace and x-axis of internal graticule		$\leq 5^\circ$	note 7
Luminance reduction with respect to screen centre			
x-axis, outer graticule line		\leq 30%	
y-axis, outer graticule line		\leq 30%	
any corner		\leq 50%	
Grid drive for 10 μ A screen current	V_d	approx. 20 V	
Line width	l.w.	approx. 0.33 mm	note 8

LIMITING VALUES (Absolute maximum rating system)

Final accelerator voltage	$V_{g7(l)}$	max. 18 kV	Fig. 6
Shield voltage	V_{g5}	max. 3.3 kV	
First accelerator and astigmatism control voltage	V_{g4}	max. 3.3 kV	
Focusing electrode voltage	V_{g3}	max. 2.5 kV	
Grid 2 voltage	V_{g2}	max. 2.5 kV	
Control grid voltage	$-V_{g1}$	max. 200 V min. 0 V	
Cathode to heater voltage			
positive	V_{kf}	max. 125 V	
negative	$-V_{kf}$	max. 125 V	
Heater voltage	V_f	max. 6.6 V min. 5.7 V	
Voltage between g_2 and g_4	$\Delta V_{g2,g4}$	max. 2 kV	
Voltage between g_4, g_5 and any deflection plate	$\Delta V_{g4,g5,x,y}$	max. 500 V	
Grid drive, averaged over 1 ms	V_d	max. 25 V	
Screen dissipation	W_l	max. 8 mW/cm ²	
Control grid circuit resistance	R_{g1}	max. 1 M Ω	

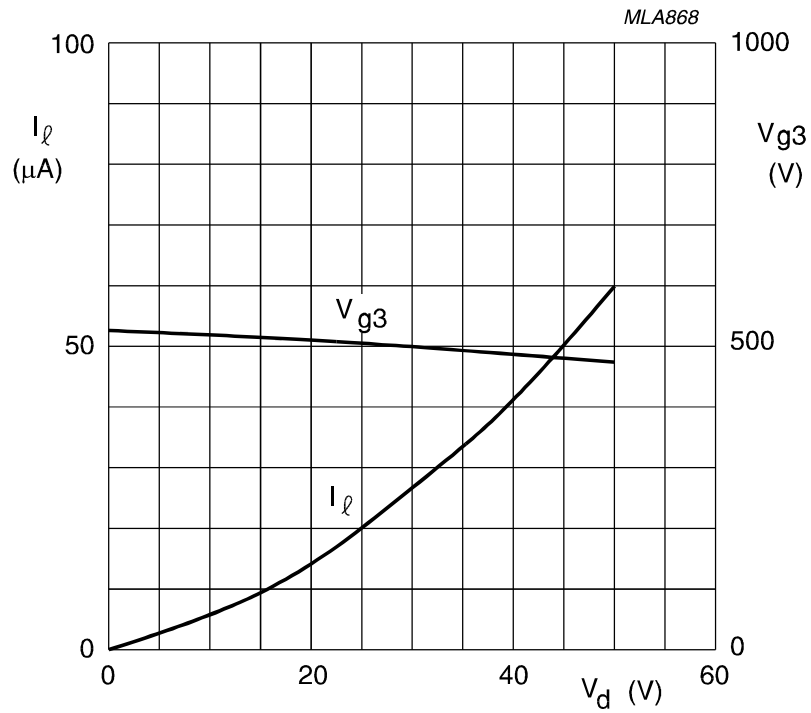

Fig.5 Screen current(I_l) and focusing voltage (V_{g3}) as a function of grid drive voltage (V_d) at $V_{g7} = 16.5$ kV, $V_{g5} = 2.2$ kV; typical curves.

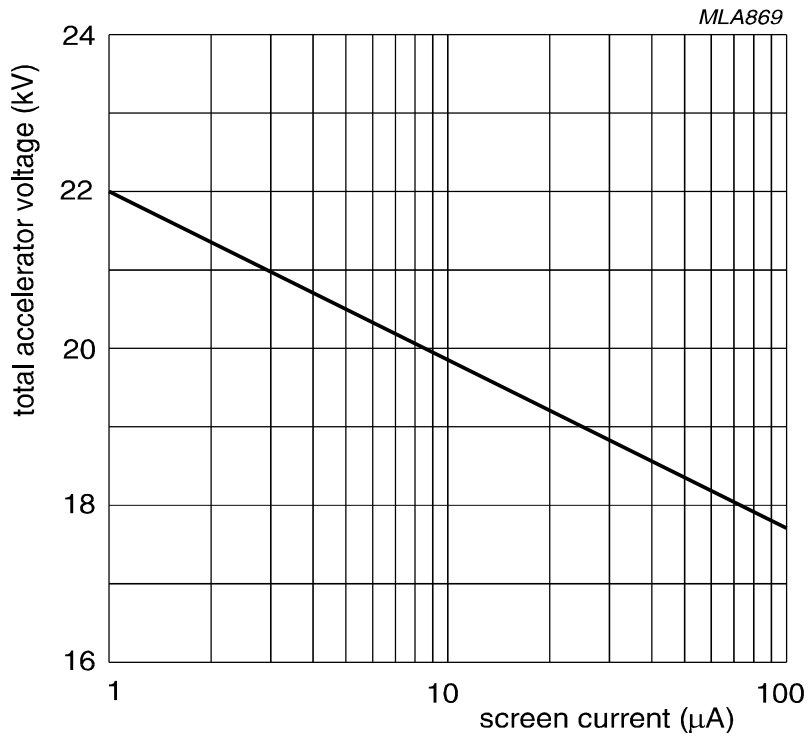

Fig. 6 0.5 mR/h isoexposure-rate limit curve. Measured according to EIA standard RS-502 , March 1989 (formerly TEPAC 104).

NOTES

1. Because the frit seal is visible through the faceplate, and is not necessarily aligned with the internal graticule, application of an external passe-partout with an open area of max. 102 mm x 82 mm is recommended. The internal graticule is aligned with the faceplate by using the faceplate reference points (see Fig.4).
2. The deflection plates must be operated symmetrically; floating mean x- or y-potentials will result into non-uniform line width and geometry distortion. The mean x- and y-potentials should be equal; under this condition the tube will be within the specification without corrections for astigmatism and geometry (see also note 5).
3. For some applications a mean x-potential up to 50 V positive with respect to mean y-potential is inevitable. In this case V_{g5} must be made equal to mean x-potential, and a range of 0 to -25 V with respect to mean y-potential will be required on g_4 for astigmatism correction. The circuit resistance for V_{g4} should be $\leq 10 \text{ k}\Omega$ and $\leq 25 \text{ k}\Omega$ for V_{g5} .
4. The deflection sensitivity over each division will not differ from the average deflection sensitivity measured over the total useful scan by more than the indicated value, in x and y direction.
5. The tube is adjusted by internal permanent magnets for optimum geometry (orthogonality, trapezium and barrel/pin-cushion), brightness uniformity, eccentricity of undeflected spot and astigmatism.
6. A graticule consisting of concentric rectangles of 100 mm x 80 mm and 98.4 mm x 78.6 mm is aligned with the internal graticule. With optimum trace rotation correction the edges of a raster will fall between these rectangles.
7. The tube has a trace rotation coil, fixed onto the lower cone part. The coil has a maximum resistance of 260Ω at 80 °C. The maximum required voltage is approx. 10 V for tube tolerances and earth magnetic field with reasonable shielding ($\pm 2^\circ$).
8. Measured with the shrinking raster method in the centre of the screen under typical operating conditions, adjusted for optimum spot size at a beam current $i_l = 10 \mu\text{A}$.
9. Grid 2 voltage (V_{g2}) may be used to adjust the cut-off voltage, otherwise it should be connected to V_{g4} . The V_{g1} range changes approximately proportional to V_{g2} .

© 2000 Professional Display Systems B.V. All rights reserved. Printed in the Netherlands.

The information presented in this document may be changed without notice. It is advisable to contact the supplier for availability and latest data before designing this product into equipment. Publication of this document does not convey nor imply any license under patent- or other industrial or intellectual property rights.