

**GENERAL DATA**

Spectral Response	See Curve
Wavelength of Max. Response	6100 ± 400 Angstroms
Sensitive Material	Cadmium-Sulfide
Sensitive Area	Viewed from End
Construction	Hermetically Sealed in Glass with Flexible Leads
Outline	See Drawing
Operating Position	Any

**ELECTRICAL DATA**

**RATINGS (Absolute Maximum Values)**

Breakdown Voltage <sup>2</sup>	300 Volts
Dissipation (See Curve)	
T-amb = 25°C	50 mW
T-amb = 70°C	5 mW
Ambient Temperature Range	-40 to +70 °C
Illumination	Note 3

**CHARACTERISTICS**

Cell Resistance <sup>4</sup>	
Illumination 2 FC	24,000 Ohms
Color Temperature 2870°K	
Dark Resistance <sup>5</sup>	2.4 Megohm Min.

**NOTES:**

1. Minute increased in relative humidity will produce change in color.
2. Measured with cell in complete darkness at a pulse rate of 100 pps, 100 μ sec. duration. Voltage in excess of the rated value may damage the cell. Max. DC or AC peak voltage is limited by max. dissipation and min. dark resistance rating.
3. Care should be exercised to prevent localized overheating of the sensitive surface when the cell is used with a lens system.
4. Measured after 60 minutes minimum exposure to approximately 50 FC illumination (ambient room light).
5. Measured in complete darkness, 10 seconds after removal of 2 FC illumination.

**QUICK REFERENCE DATA**

The Sylvania Type 8478 is a miniature cadmium-sulfide photoconductive cell featuring high sensitivity and hermetically sealed-in-glass construction. The cell is gaseous back-filled for a high dissipation safety factor and includes a blue dot compound which turns pink<sup>1</sup> if the cell envelope become damaged. The 8478 is designed for use in a wide variety of industrial applications.

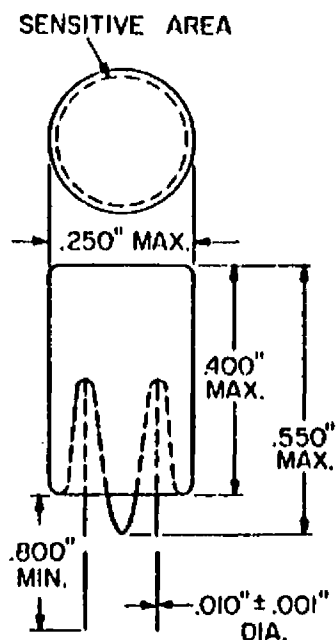

**SYLVANIA ELECTRIC PRODUCTS INC.**

**Electronic Components Group  
ELECTRONIC TUBE DIVISION  
EMPORIUM, PA.**

*A Technical Publication*

July 9, 1964  
Page 1 of 4

SPECTRAL RESPONSE

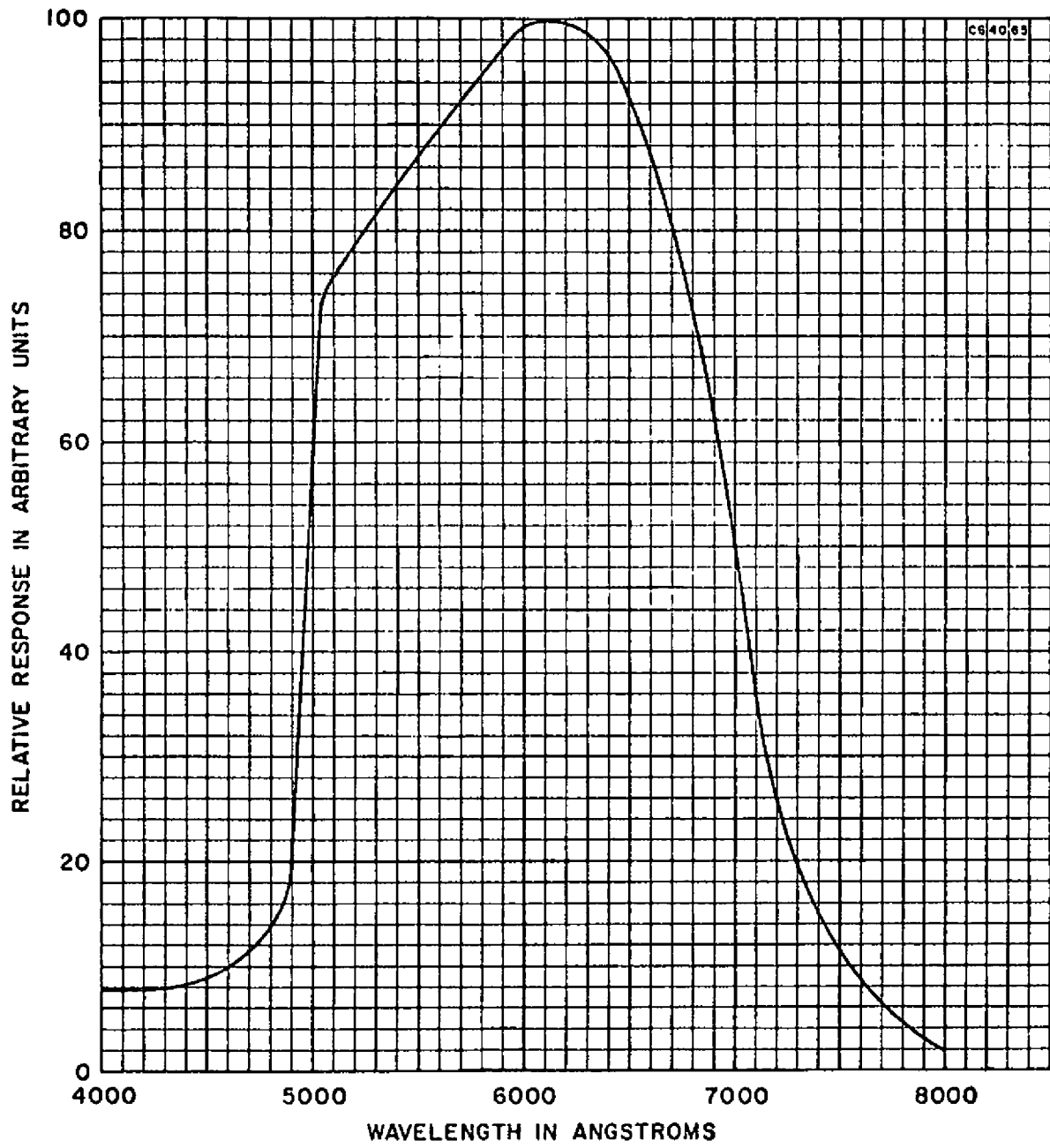

SPECTRAL CHARACTERISTIC OF HUMAN EYE,  
TUNGSTEN AND FLUORESCENT LAMPS

C62017

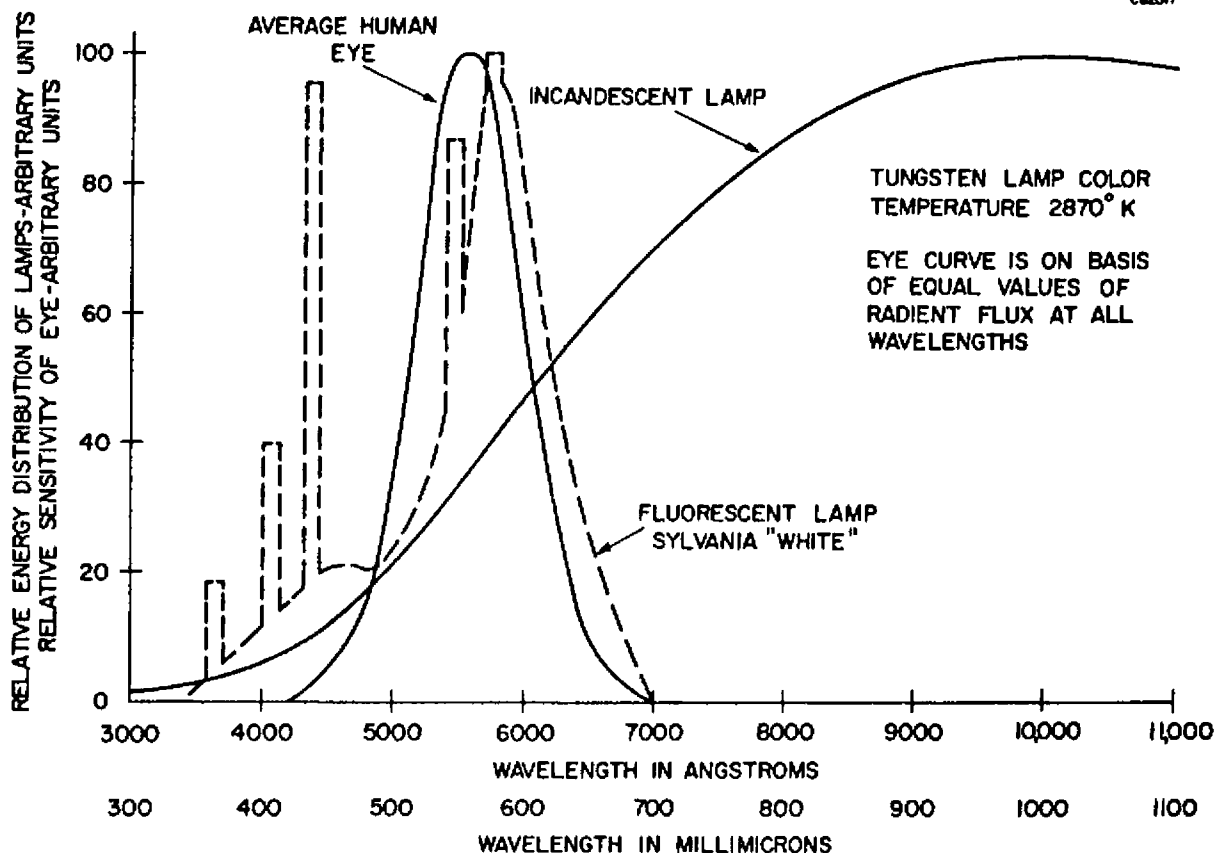

PERMISSIBLE DISSIPATION AS A FUNCTION OF AMBIENT TEMPERATURE

C62040

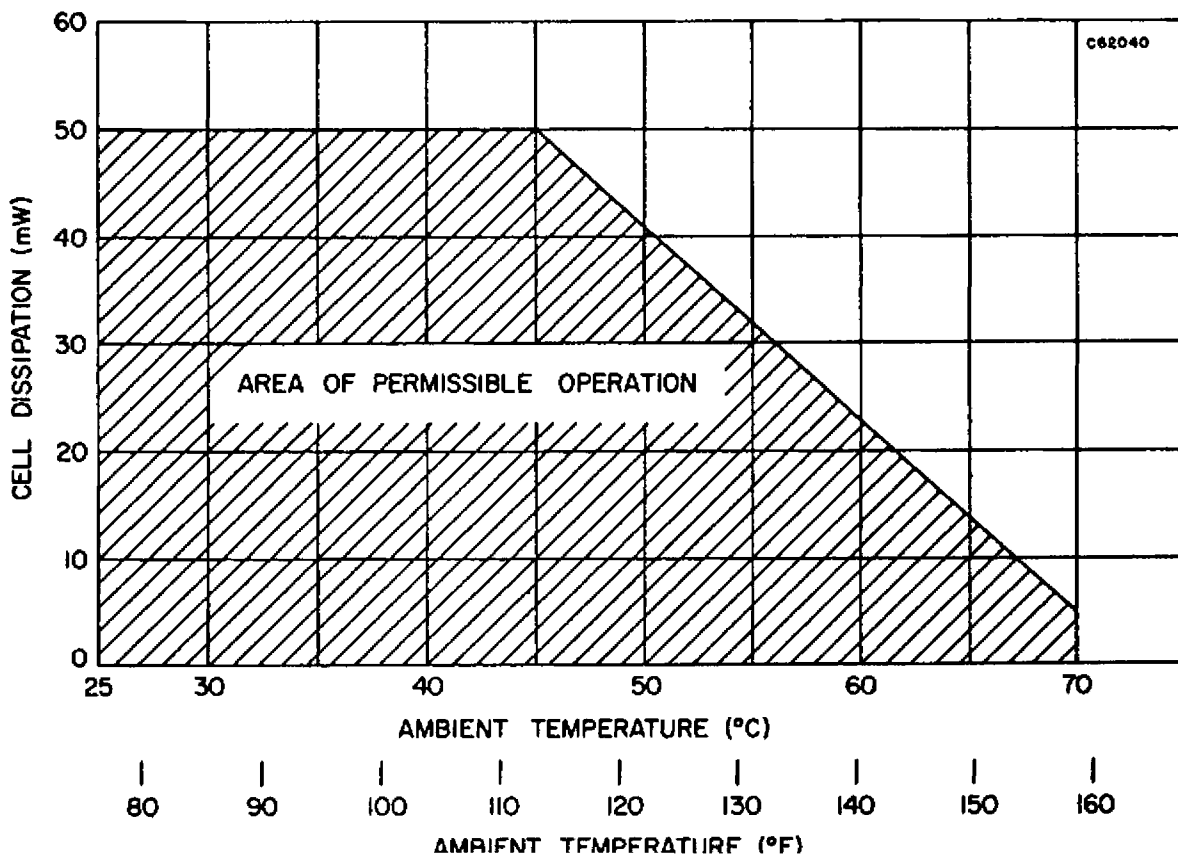

CELL RESISTANCE VS ILLUMINATION

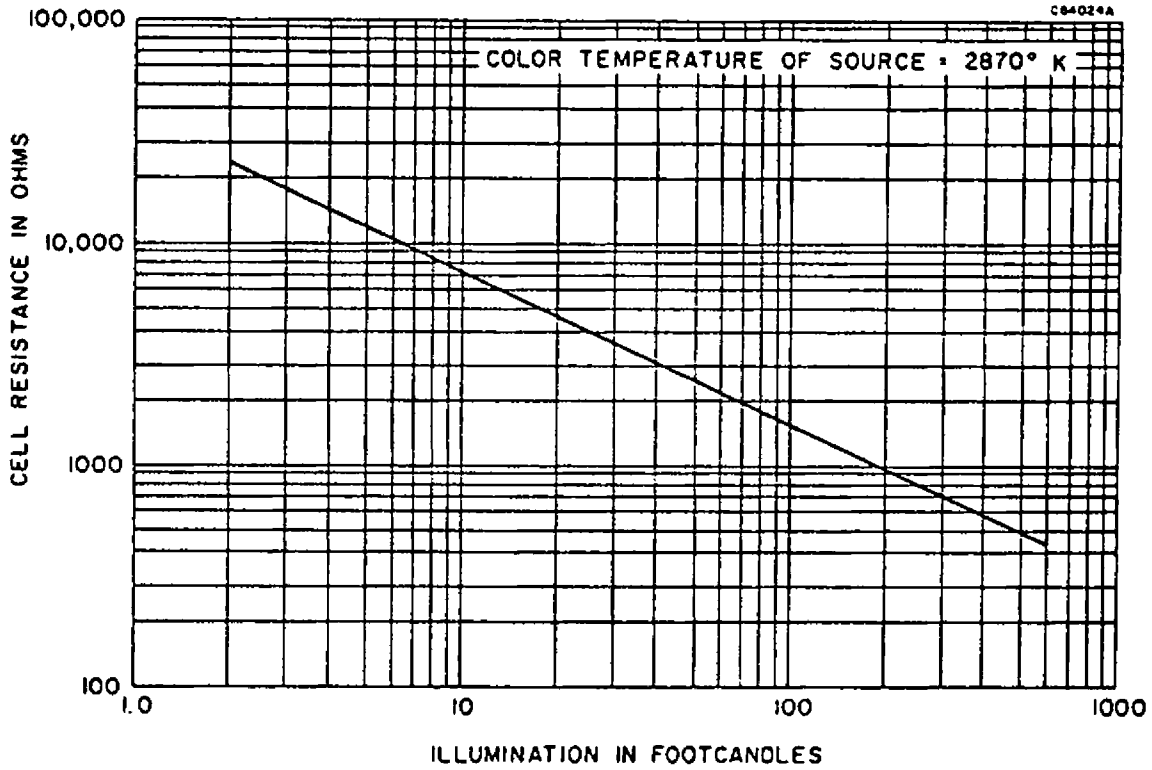

CELL CURRENT AND DISSIPATION VS VOLTAGE

